



CFMOTO

SERVICE MANUAL

TERRALANDER 800

CF800-2 4x4

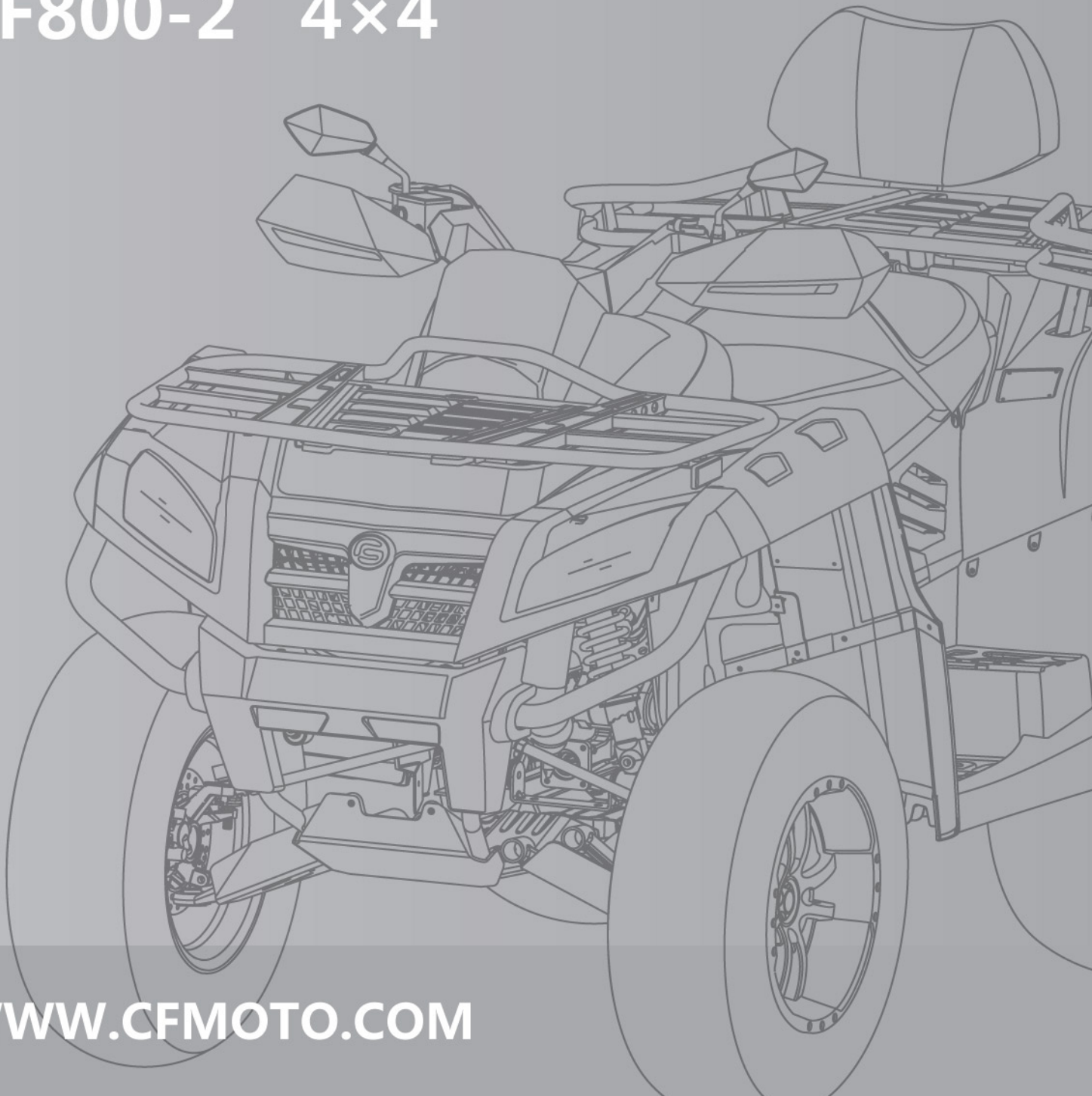

WWW.CFMOTO.COM

FOREWORD

This manual introduces CF800-2 maintenance information, removal&installation procedure, check & adjustment methods, troubleshooting and technical specifications in detail. There are illustrations to guide your operations.

Chapter 1 mainly introduces general operation information, service tools, vehicle structure and basic specifications.

Chapter 2 mainly introduces check & adjustment methods and how to do vehicle maintenance.

Chapter 3 and further chapters mainly introduce removal, installation, adjustment, maintenance and troubleshooting information.

CFMOTO reserves right to make improvements and modifications to the products without prior notice. Overhaul and maintenance should be done according to actual condition of vehicle.

All rights reserved
Zhejiang CFMOTO Power Co., Ltd.
June. 2011

INDEX

General Information	1
Body and Muffler	2
Inspection and Adjustment	3
Cooling System	4
Engine Removal and Installation	5
Air Intake System	6
Intake Manifold,Cylinder Head and Cylinder	7
Crankcase,Crankshaft,Gearbox	8
CVT and Clutch	9
Engine Lubrication System	10
Magneto System	11
Front Wheels,Brake,Suspension,Steering	12
Rear Wheels,Brake,Suspension	13
Front Differential,Rear Gearcase	14
Electrical System	15
Lights,Instrument,Switches	16
Troubleshooting	17

Unit Conversion Table

Item	Example	Conversion
Pressure	200kPa(2.00kgf/cm ²)33kPa(250mmHg)	1 kgf/cm ² =98.0665kPa 1kPa=1000Pa 1mmHg=133.322Pa=0.133322kPa
Torque	18N · m(1.8kgf · m)	1 kgf · m=9.80665N · m
Volume	419ml(419cm ³ ,419cc) 419ml(0.419l)	1 ml=1 cm ³ =1 cc 1l=1000 cm ³
Force	12N(1.2kgf)	1 kgf=9.80665N

Maintenance information.....	1-1	Tightening torque table.....	1-13
Location of VIN/EIN.....	1-3	Lubricants and service products...	1-19
General specifications.....	1-4	Wiring, pipes & cables	1-20
Maintenance specifications.....	1-6	MIL/ EVAP system.....	24

MAINTENANCE INFORMATION

Operation cautions

1. Engine exhaust fumes are poisonous and can result in loss of consciousness or death. Do not run the engine in an enclosed or poorly ventilated area.
2. Do not touch the engine or muffler with bare hands after the engine has been just stopped to avoid burns. Wear long-sleeve work clothes and gloves for operation.
3. Battery electrolyte (dilute sulfuric acid) is highly caustic and can result in burns from contact with skin and eyes. If you spill electrolyte on skin, flush with water and seek for medical attention immediately. If you spill electrolyte on clothes, flush with water if to avoid burns. Keep battery and electrolyte out of reach of children.
4. Coolant is poisonous. Do not drink or spill it on skin, eyes or clothes. If you spill coolant on skin, immediately wash with soap and water. If you spill coolant on eyes, flush with water and seek prompt medical attention. If you swallow coolant, induce vomit and see the doctor. Keep coolant out of reach of children.
5. Wear proper work clothes, cap and boots. If necessary, wear dust-glass, gloves and mask.
6. Gasoline is highly flammable. No smoking or fire. Also keep gasoline away from sparks. Vaporized gasoline is also explosive. Operate in a well-ventilated area.
7. When the battery is being charged, it produces explosive gases. Charge the battery in a well-ventilated area.
8. Be careful not to get pinched by the turning parts like wheels and clutch.
9. When more than two people are operating, keep reminding each other for safety purpose.

Cautions for removal and installation

1. Use genuine CFMOTO parts, lubricants and service products.
3. Clean mud, dust before servicing.
2. Store the removed components separately in order for correct installation.
4. Replace the removed washers, o-rings, piston pin retainers, cotter pins with new ones.
5. Elastic retainers might get distorted after disassembled. Do not use the loosened retainers.
6. Clean and blow off the detergent after removal. Apply lubricants on the surface of moving parts. Measure the data during removal for correct installation.
7. If you do not know the length of screws, install the screws one by one and make sure they are screwed in with the same depth.
8. Check if the removed rubber parts are aged and replace if necessary. Keep the rubber parts away from grease.
9. Pre-tighten the bolts, nuts and screws, then torque to specification. The basic sequence is from big to small, from inner side to outer side and criss-cross.
10. Replace aged rubber parts when assembling. Do not splash gasoline, grease onto the surface, as this could cause damage.

-
11. Apply or inject recommended lubricant to the specified lubrication points.
 12. Use special tools when necessary.
 13. When ball bearing is removed by pressing steel balls, it can not be reused.
 14. Finger turn the inner and outer rings of ball bearing to make sure the bearing will turn smoothly.
 - Replace if the axial or radial play is too big.
 - If the surface is uneven, clean with oil and replace if the cleaning does not work.
 - When pressing the bearing into the machine or onto the shaft, if the bearing can not be securely seated, replace it.
 15. Install the one-side dust-proof bearing in the right direction. When assembling the open type or double-side dust-proof bearing, install with manufacturer's mark outward.
 16. Keep the bearing block still when blowing dry the bearing after washing clean. Apply oil or lubricant before installation.
 17. Install the elastic circlip properly. Turn the circlip after assembling to make sure it has been installed into the slot.
 18. After assembling, check if all the tightened parts are properly tightened and can move smoothly.
 19. Brake fluid and coolant may damage painting, plastic and rubber parts. Flush with water if splashed on these parts.
 20. Install oil seal with the side of manufacturer's mark outward.
 - Do not fold or scratch the oil seal lip.
 - Apply grease to the oil seal lip before assembling
 21. When installing pipes, insert the pipe till the end of joint. Fit the pipe clip, if any, into the groove. Replace the pipes or hoses that cannot be tightened.
 22. Do not mix mud or dust into engine and/or the hydraulic brake system.
 23. Clean the gaskets and washers of the engine casing before assembling. Remove the scratches on the joint faces by polishing evenly with an oilstone.
 24. Do not twist or bend the cables too much. Distorted or damaged cables may cause poor
 25. When assembling the parts of protection caps, insert the caps to the grooves, if any.

ENGINE BREAK-IN

There are many movable components inside the engine, such as piston, piston ring, cylinder, crankshaft, gears and so on. During initial use period, proper run-in for every critical component is necessary. Break-in can help engine components match each other better and adjust working condition. Careful treatment of a new engine will result in more efficient performance and a longer service life.

Recommended break-in period: First 20 hours

Operation guide:

0~10 Hours

Do not operate continuously at more than 50% throttle position.

Cool down the engine for every 5~10 minutes after every 1 hour operation.

Avoid sudden acceleration. Vary the throttle position slowly and smoothly. Do not vary the throttle position rapidly.

10~20 Hours

Avoid long-time run at more than 75% throttle position. Do not open throttle completely during the period.

ATTENTION:

- 1. Maintain and repair as regular procedures during break-in period.**
- 2. After break-in, do not forget to check and maintain the engine before normal use.**

LOCATION OF VIN/EIN

Model Number: CF800-2

1. Vehicle identification number(VIN): LCELVYZ3~
2. Name plate (Vehicle identification number label)
3. Engine identification number(EIN): 2V91W~

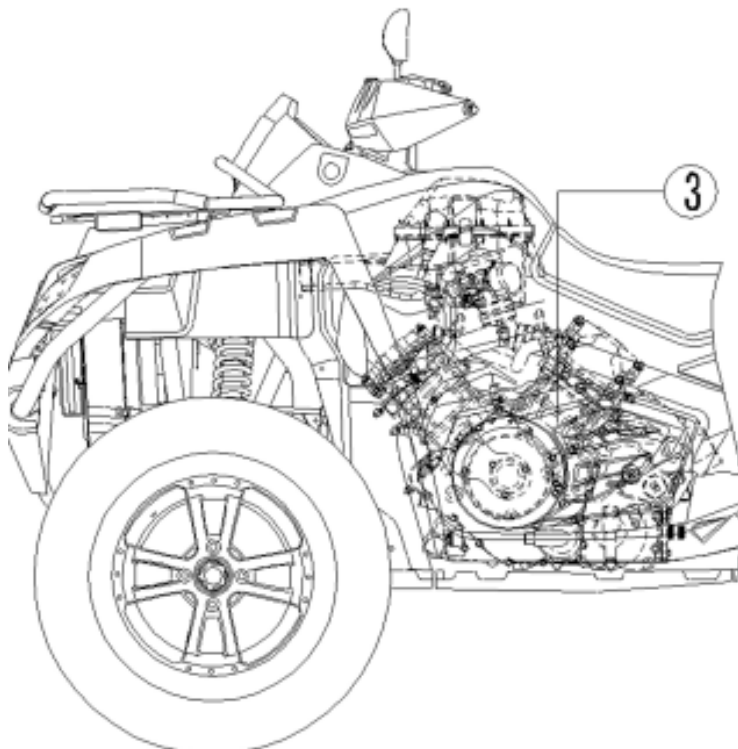
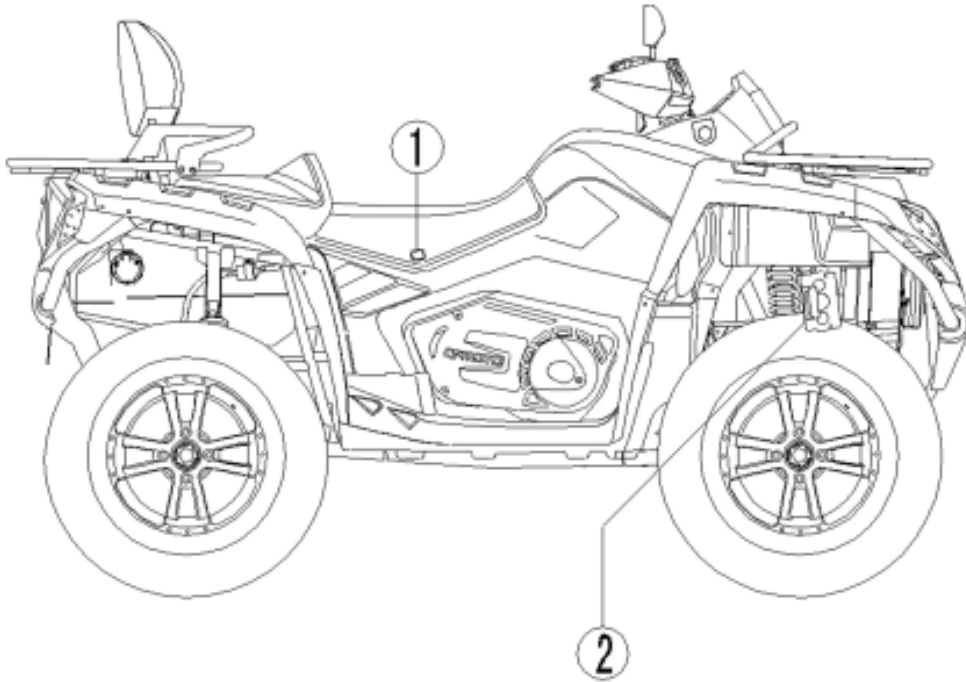

1 GENERAL INFORMATION

Item		Specifications
Model type		CF800-2
Overall length		2310mm
Overall width		1180mm
Overall height		1340mm
Wheelbase		1480mm
Engine type		2V91W
Displacement		800ml
Fuel type and Octane No.		RQ-93 or higher unleaded gasoline
Dry weight		400 kg
Passengers		2 persons (including driver)
Total vehicle load allowed		2persons +105 kg =255 kg
Tire	Front	AT26×9—12 49J
		AT26×9—14 48J
	Rear	AT26×11—12 55J
		AT26×11—14 54J
Min. ground clearance		270mm
Min. turning radius		8000mm
Engine	Starting	Electric start
	Type	V-twin cylinder,4-stroke,liquid-cooled,8 valves,SOHC
	Valves	SOHC /Timing chain drive
	Bore×Stroke	91mm×61.5mm
	Compression ratio	10.3:1
	Lubrication	Wet sump, replaceable oil filter
	Oil pump	Rotor drive
	Oil filter	Paper type, replaceable
	Engine oil type	SAE15W-40/SG or higher
	Cooling system	Liquid-cooled/close-loop cooling
	Coolant type	-30°C anti-corrosion and anti-freezing

1 GENERAL INFORMATION

Item		Specifications				
Air intake devices	Air filter type		Paper filter element			
	Throttle body	Type	0800-173000			
		Diameter of throttle body	48mm			
Fuel tank capacity		23 L				
Drive train	Clutch type		Wet shoes and auto centrifugal			
	Transmission type		CVT+ Gearshift			
	Gearshift		High, Low and Reverse			
	Gearshift methods/orders		Manual operation/L-H-N-R-P			
	CVT ratio range		2.88~0.70			
	Gearshift ratio			"H" gear	"L" gear	"R" gear
		Final ratio		1.333		
		Secondary ratio		1.952		
		Single gear ratio		1.143	2.529	2.231
		Total ratio		2.975	6.585	5.807
	Ratio of drive gear		Front	33 / 9 = 3.667		
			Rear	33 / 9 = 3.667		
Output type		Front/Rear shaft drive				
Rotation of engine output		When forward, clockwise (rear view)				
Steering	Turn angle	Left	31°			
		Right	31°			
Brakes		Front	Hydraulic Disc			
		Rear	Hydraulic Disc			
Suspension		Double A-arm and independent				
Frame type		Steel tube and plate				

MAINTENANCE SPECIFICATIONS

Lubrication System

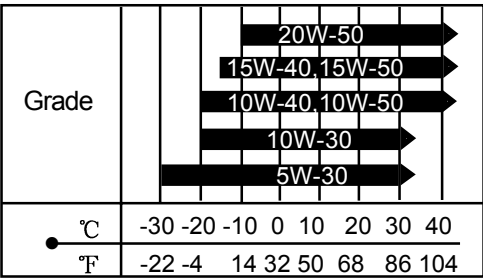
Item		Standards	Service Limit
Engine Oil Capacity	Oil Change	3400ml(without oil filter replacement)	-
	Oil Change	3500ml(with oil filter replacement)	
	Oil Capacity	3600ml	-
	Oil Inside the Oil Radiator and Hoses	600ml(Note:fill after first start)	
Grade	 <p> Recommended engine oil:SAE 15w40 API SG.If it's not available,select alternative according to the following specifications. • API classifications: SG or higher • Viscosity rating: according to the left chart </p>		
Oil Pump Rotor	Clearance Between Inner and Outer Rotor	0.06-0.14mm	0.25mm
	Clearance Between Outer Rotor and Bore	0.09-0.15mm	0.25mm
	Rotor End Clearance	0.023-0.109mm	0.20mm
	Oil Pressure	1500rpm:70-300kPa(90),Typical:180kPa 6000rpm:350-550kPa(90),Typical:420kPa	

Air Intake System

Item	Standards and Specifications
Fuel Tank	Total Capacity 23L
Throttle Body Part NO.	0800-173000
T-MAP Sensor Part No.	0800-175000
Fuel Injector Part No.	0800-171000
Idle Speed	1300±100rpm

1 GENERAL INFORMATION

Item		Standards		Service limit
Coolant capacity	Full capacity	3000ml		
	Capacity of reservoir tank	380~600ml		
	Standard density	50%		
Opening pressure		108kpa(1.1kgf/cm ²)		
Thermostat	Opening temperature	65±2℃		
	Fully opening	85℃		
	Travel when fully opening	When 85℃, >5mm		
Relationsbetween water temp.and resistance of water temp. sensor	Water temperature (℃)	Resistant of B terminal (Ω)	Resistant of A,C terminal (kΩ)	
	-20	----	28.582±0.004	
	25	-----	2.795±0.0025	
	50	216.0-216.4	0.98±0.00227	
	80	74.6-90.6	0.334±0.00204	
	110	32-36	0.133±0.00252	
Working temp. of thermoswitch	OFF-ON	Around 88℃	Around 88℃	
	ON-OFF	Around 82℃	Around 82℃	
Coolant type	-30℃ anti-freezing, anti-corrosive and high boiling point			

1 GENERAL INFORMATION

Item			Standard value	Service limit
Front wheel	Rim jump	Longitude	1.0mm	2.0mm
		Transverse	1.0mm	2.0mm
	Front tire	Remaining groove		3.0mm
		Pressure	45kPa (0.45kgf / cm ²)	

Item			Standard value	Service limit
Rear wheel	Rim jump	Longitude	1.0mm	2.0mm
		Transverse	1.0mm	2.0mm
	Rear tire	Remaining groove		3.0mm
		Pressure	45kPa (0.45kgf / cm ²)	

Item			Standard value	Service limit
Front brake	Free play of brake lever		0mm	
	Thickness of brake disc		3.5mm	2.5mm
Rear brake	Free play of brake lever		10-20 mm	
	Free play of brake pedal		0mm	
	Thickness of brake disc		7.5mm	6.5mm

1 GENERAL INFORMATION

Item		Standards	
AC Flywheel	Type	Magneto 3-phase AC generator	
	Output	3-phase AC output	
	Resistance of coil (20°C)	0.2Ω-0.3Ω	
	Resistance of pick-up coil	250Ω-300Ω	
	Voltage without load(cold engine)	> 100V (AC), 5000r/min	
	Max. output power	350W, 5000r/min	
	Stable voltage	13.5V-15.0V, 5000r/min	
	Peak voltage of pick-up	≥1.5V, 200 r/min	
Regulator type		3-phase supply power of thyristor trigger circuit	
Battery	Capacity	12V 30Ah	
	Voltage between terminals	Fully recharged	14.4V
		Not-fully recharged	≤11.8V
	Recharging current/time	Standard	1A / 5~10H
Quick		5A / 1H	

Item		Standards
Ignition type		ECU
Spark plug	Type	Resistant-type
	Standard	DCPR8E (NGK)
	Gap of spark plug	0.8-0.9mm
	Characteristic	> 8mm, under 1Kpa
Ignition time	BTDC10° 1500r/min	
Resistance of ignition coil	Primary	0.70Ω-0.75Ω
	Secondly	6.0kΩ-7.0 kΩ
Peak voltage	Primary	> 150V
	Pulse voltage	2V
Resistance of starter relay coil		3Ω-5Ω
Resistance of auxiliary relay coil		90Ω-100Ω

Item		Standards
Fuse	Main	30A
	Auxiliary	10A×1 15A×5
Light & Bulb	Headlight (Hi / Lo)	12V—35W/35W×2
	Front position light	12V—5W×2
	Brake light/Tail light	12V—21W/5W×2
	Turn signal light	12V—10W×4
	Dashboard indicator light	LED
	Water temperature, fuel level, 2x4 drive indicator light	LCD
	MIL	LED

1 GENERAL INFORMATION

Valves & Cylinder Head

Item	Standard value		Service limit	Remarks
Dia. Of valve neck	Intake valve	φ33	—	
	Exhaust valve	φ29	—	
Thickness of valve neck	Intake/Exhaust	1	0.5	
Valve clearance(cold engine)	Intake	0.06-0.14	—	
	Exhaust	0.11-0.19	—	
Inner dia. Of valve guide	Intake/Exhaust	5.000-5.012	5.045	
Gap between valve guide and stem	Intake	0.020-0.047		
	Exhaust	0.030-0.057		
Valve length	Intake	90.1		
	Exhaust	88.7		
Width of valve seat seal	Intake valve	1.2±0.1	1.7	
	Exhaust valve	1.3±0.1	1.8	
Valve spring free length	Intake/Exhaust	40	38.2	
Elasticity of valve spring	Intake/Exhaust	33: 200-235N 23: 530-587N		
Axial clearance of camshaft	0.12-0.28			
Camshaft run-out			0.10	
Bore diameter of rocker arm	Intake/Exhaust	12.000-12.018	12.03	
Flatness of cylinder head bottom surface	0.03		0.05	

1 GENERAL INFORMATION

Cylinder, Piston, Piston Ring & Crankshaft

Item	Standards		Service limit	Remarks
Cylinder compression	1000kPa			
Piston/Cylinder clearance	0.03-0.05		0.10	
Flatness of cylinder top and bottom surface	0.03		0.05	
Gap of piston ring	1st ring	0.25-0.40	1.5	
	2nd ring	0.35-0.45	1.5	
	Oil ring	0.2-0.7	1.5	
Height of piston ring	1st ring	1.17-1.19		
	2nd ring	1.47-1.49		
	Oil ring	2.37-2.47		
Height of piston groove	1st ring	1.21-1.23		
	2nd ring	1.51-1.53		
	Oil ring	2.50-2.52		
Ring/Piston groove clearance	1st ring	0.02-0.06	0.15	
	2nd ring	0.02-0.06	0.15	
	Oil ring	0.03-0.15	0.25	
Piston bore	22.004-22.010			
Inner diameter of small end of connecting rod	22.01-22.02		22.06	
Diameter of piston pin	21.995-22.000		21.980	
Gap of piston/piston pin	0.004-0.015		0.08	
Gap of piston pin/small end hole of connecting rod	0.010-0.025		0.08	
Side gap of big end of connecting rod	0.3-0.56		0.8	
Gap of connecting rod bearing	0.022-0.049		0.09	
Gap of main bearing	0.02-0.05		0.09	
Gap of crankshaft axial direction	0.05-0.35		0.6	

1 GENERAL INFORMATION

Clutch + CVT + Gearbox

Item	Standard value	Service limit	Remarks
Inner dia. of clutch friction disc	140.00-140.15	140.5	
Clutch engagement RPM	1800-2400r/min		
Clutch locking RPM	3300-3900r/min		
Belt width	34.5 (Cord layer)	33.5	
Free length of driven pulley spring	238.5		
Hole dia. of driven pulley collar	38.10-38.14	38.30	
Groove width of gearshift	6.10-6.20	6.30	
Output gear width of driven shaft	6.10-6.20	6.30	
Thickness of left and right gearshift fork	5.80-5.90	5.70	
Clearance between gearshift fork and engagement groove	0.20-0.40	0.50	
Groove width of gearshift drum	8.05-8.10		
Dia. of gearshift pawl pin	7.90-7.95	7.83	

1 GENERAL INFORMATION

Tightening Torque

Items	TorqueN·m(kgf·m)	Items	TorqueN·m(kgf·m)
5mm Bolt,Nut	5(0.5)	5mm Screw	4(0.4)
6mm Bolt,Nut	10(1.0)	6mm Screw	9(0.9)
8mm Bolt,Nut	20(2.0)	6mmSH Flanged bolt	10(1.0)
10mm Bolt,Nut	34(3.5)	6mm Flanged bolt, nut	12(1.2)
12mm Bolt,Nut	54(5.5)	8mm Flanged bolt, nut	20(2.0)
		10mm Flanged bolt, nut	39(4.0)

Fasteners not included in below table should also be torqued to specification. Note: Threads and contact area should be applied by engine oil.

Ref. No.	Items	Part number	Qty	Torque (N·m)
1	Mount bolt, upper part of engine	GB5789 M8x35	2	35~45
2	Bolt, upper bracket of engine	GB5789 M10x1.5x20	2	40~50
3	Mount bolt, front and left side of engine	GB5789 M10x1.25x125	1	40~50
4	Mount bolt, front and right side of engine	GB5789 M10x1.25x100	1	40~50
5	Mount bolt, front bracket of engine	GB5789 M8x20	6	35~45
6	Mount bolt, rear part of engine	GB5789 M10x1.25x170	1	40~50
7	Bolt, rear bracket of engine	GB5789 M8x20	6	35~45
8	Bolt, rocker arm	GB5789 M10x1.25x70	16	40~50
9	Bolt, front shock absorber	GB5789 M10x1.25x50	2	40~50
		GB5789 M10x1.25x70	2	
10	Bolt, rear shock absorber	GB5789 M10x1.25x50	2	40~50
		GB5789 M10x1.25x70	2	
11	Bolt, bracket of rear wheel axle	GB5789 M10x1.25x140	4	40~50
12	Mount nut, rim	901B-070002	16	70~80
13	Nut, rim shaft	901-07.00.03	4	110~130
14	Bolt, rear brake caliper	GB70 M10x1.25x20	2	30~40
15	Bolt, front brake disc	901-08.00.03	8	25~30
16	Bolt, front brake caliper	GB5789 M8x16	4	15~25
17	Bolt, cover of handlebar	GB5789 M8x55	4	15~25
18	Mount bolt, muffler	GB5789 M10x1.25x70	1	40~50
29	Lower bolt, muffler body	GB5789 M8x68	1	15~25
20	Bolt, muffler clamp	GB5789 M8x35	1	15~25
21	Bolt, rear axle	GB5787 M10x1.25x110	2	40~50
22	Bolt, front axle	GB5787 M10x1.25x90	1	40~50
23	Bolt, front axle	GB5787 M10x1.25x25	2	40~50
24	Bolt, bracket of front axle	GB5789 M8x14	2	15~25
25	Bolt, rear end of rear drive shaft	9010-300001	6	40~50
26	Bolt, front end of rear drive shaft	9010-290001	4	30~40
27	Bolt, front drive shaft	9010-290001	8	30~40

1 GENERAL INFORMATION

Item	Qty	Dia. Of thread(mm)	Torque (N.m)	Remarks
Bolt M14X1.5	2	M14x1.5	25	
Plug screw, oil passage of left crankcase	1	ZM14	20	Apply glues
Oil drain boltM12x1.5	1	M12x1.5	20	
Flange bolt M8x12.5 (left crankcase)	1	M8x12.5	20	
Screw R ₂ 1/8 (oil passage)	2	R ₂ 1/8	20	Apply glues
Nut M6(right crankcase)	4	M6	10	
Stud AM6x35-8.8 (right crankcase)	4	AM6x35	10	Threadlocker
Screw M6x12 (CVT cover)	1	M6x12	8	
Bolt of wiring clasper(left crankcase cover)	2	M5x10	6	Threadlocker
Screw of oil seal plate(left crankcase cover)	3	M6x8	8	
Bolt M12x1.25(Magneto rotor)	1	M12x1.25	105	Threadlocker
Adjust nut, valve clearance	8	M6	12	
Bolt, timing sprocket	2	M8	30	Threadlocker
Plunger, tensioner	2	M16x1.5	0.1	
Plug screw, tensioner	2	M18x1	4.5	
Bolt, cylinder	8	M10	20,60	
Thrust nut M8 (exhaust pipe)	4	M8	13	
Spark plug	2	M12x1.25	20	
Stud M8x42 (exhaust pipe)	4	M8x42	10	Threadlocker
Plug screw M12x1.5 (head of cylinder 1)	1	M12x1.5	20	
Tapping screw ST5.5x13(thermostat cap)	1	ST5.5x13	5	
Screw, tensioner plate	2	M6x15.5	10	Threadlocker
Bolt M8, intake manifold	4	M8	20	
Bolt, connecting rod	4	M9x1	10,20,50	
Nut M18x1.5(left) (right crankcase)	1	M18x1.5	70	Left thread

1 GENERAL INFORMATION

To be continued

Item	Qty	Thread Dia. (mm)	Torque (N.m)	Remarks
Nut, drive shaft (CVT drive pulley)	1	M20×1.5	115	Threadlocker
Nut,main shaft (CVT driven pulley)	1	M20×1.5	115	Threadlocker
Lock nut, bevel gear	1	M22×1	145	
Bolt M8x28(bearing seat, drive bevel gear)	4	M8×28	32	
Screw M8x5 (bearing holder, drive bevel gear)	4	M8×5	15	
Stopper nut,M65X1.5(driven bevel gear)	1	M65×1.5	110	Threadlocker
Nut M8X28(bearing housing, driven bevel gear)	4	M8×28	25	
Screw T25(shift fork drum)	1	M5×8	6	
Spring seat, Limit	1	M12×1	20	
Screw M5×16 (oil pump)	3	M5×16	7	Threadlocker
Screw M8X20 (overriding clutch)	6	M8×20	30	Threadlocker
Bolt M6×30 (Magneto stator)	3	M6×30	10	Threadlocker
Bolt, valve cap	8	M6	7	
Bolt M6×45(thermostat cap, cylinder 1)	2	M6×45	6	
Bolt M6×25 (Tensioner, thermostat cap of cylinder 2)	6	M6×25	6	
Water temperature sensor	1	M12×1.5	16	
Switch of oil pressure	1	M10×1	12	Threadlocker
Retainer, bearing (left)	1	M55×1.5	80	Threadlocker, left thread
Other bolts		M5	4.5-5.5	
		M6	8-12	
		M8	25	

1 GENERAL INFORMATION

Engine Service Tools

Item	Tool name	Specifications	Purposes
1	Vernier caliper	0-150mm	Measure length and thickness
2	Micrometer	0-25mm	Measure outer diameter of rocker arm shaft, valve stem, camshaft
3	Dial gauge	25-50mm	Measure Max. travel of camshaft
4	Dial gauge	75-100mm	Measure size of piston skirt
5	Inner dia. of cylinder meter		Measure cylinder size & pressure
6	Inside caliper micrometer	10-34mm	Measure inner diameter of rocker and piston pin hole, connecting rod hole
7	Dial indicator	1/100	Measure jump
8	Knife straight edge		Measure flatness
9	Feeler gauge		Measure flatness and adjust valve clearance
10	Oil guage		Measure fuel level of carburetor
11	Plastigauge		Measure fit clearance
12	Spring balance		Measure elasticity of spring
13	RPM meter		Measure RPM
14	Compression tester and adapter		Measure cylinder compression
15	Oil pressure meter		Measure oil pressure
16	Air pressure meter		Measure opening pressure of radiator cover
17	Ohmmeter		Measure resistance and voltage
18	Amperometer		Measure current of switch
19	Thermometer		Measure coolant temp.
20	Timing light		Measure ignition timing
21	Torque wrench	One set	Measure tightening torque
22	Alcohol light		Warm up or increase temp.
23	Magnetic meter seat		Mounting dial indicator
24	Plate		Auxiliary measurement
25	V-shaped bluff		Auxiliary measurement for jump
26	Nipper		Mounting valve lock-clip
27	Double clip reed		Disassembly and assembly of double clip
28	Pinching tools		Disassembly and assembly of retainer
29	Impact driver		Disassembly of crosshead bolt
30	Screw driver		
31	Plus driver		

1 GENERAL INFORMATION

Service Tools

Part number	Tool name	Purposes
0800-000000-871-001	Joint, oil hose	Measure oil pressure
0800-014001-922-003	Remover, bearing 60/28 of left crankcase	Remove bearing 60/28
0800-014001-921-002	Press tool, bearing of left crankcase	Press bearing
0800-041000-922-001	Screw, locking crankshaft	Lock crankshaft
0800-031000-922-001	Remover, magneto rotor	Remove magneto rotor
0800-013201-922-001	Remover, bearing 6003 of CVT case	Remove bearing 6003
0800-013201-921-001	Damper, CVT case cover	Support CVT case cover when pressing bearing
0800-052000-922-003	Split tool, drive & driven pulley	Split driven fixing and moving sheave to install belt
0800-051204-923-001	Installation tool, drive pulley oil seal	Install drive pulley oil seal 35×42×4
0800-052000-922-002	Remover, driven pulley	
0800-052000-922-001	Wrench, CVT driven pulley	Fix nut of driven pulley when installation
0800-013101-922-001	Remover, bearing 6208 of CVT case	Remove bearing
0800-013101-921-001	Damper, CVT case	Support CVT case when pressing bearing
0800-013104-923-001	Installation tool, clutch housing oil seal	Install oil seal of CVT clutch housing 34×55×9
9010-180100-922-001	Radiator test cap	Measure cooling system pressure
0800-014001-922-002	Puller, oil seal	Remove oil seal
0800-014001-922-001	Puller, bearing	Remove bearing
0800-014001-921-003	Press tool, bearing	Press bearing
0800-022800-922-001	Sleeve, spark plug	Disassemble/install spark plug
0800-024001-922-001	Locking tool, camshaft	Lock up and fix camshaft
0800-000000-871-002	Joint, cylinder pressure meter	Measure cylinder pressure
0800-022102-922-001	Remover, valve guide	Remove valve guide
0800-022102-922-002	Installer, valve guide	Install valve guide
0800-040003-922-001	Compressor, piston ring	Compress piston ring when installation
0800-040005-922-001	Installer, circlip	Install circlip of piston pin
0800-011201-923-001	Oil seal installer, breather	Install oil seal of breather
0800-011201-921-003	Installation jig, breather gear shaft	Support breather gear shaft
0800-011201-921-001	Press tool, breather gear shaft	Press breather gear shaft
0800-011101-922-001	Support tool, left crankcase plain bearing removing	Support left crankcase when removing plain bearing
0800-012101-922-001	Support tool, right crankcase plain bearing removing	Support right crankcase when removing plain bearing
0800-011102-922-001	Remove/install tool, roller bearing	Remove/install bearing
0800-060000-923-001	Press tool, front output shaft oil seal	Install oil seal 35×61×9 of front output shaft

1 GENERAL INFORMATION

0800-062301-923-001	Installer, front output shaft	Install front output shaft
0800-062206-922-001	Nut sleeve, driven bevel gear bearing	Install/remove nut of driven bevel gear
0800-062204-923-001	Press tool, oil seal of driven bevel gear	Install oil seal of driven bevel gear 34×50×7
0800-062000-922-001	Backlash measurement tool	Measure backlash between drive bevel gear and driven bevel gear
0800-060002-922-001	Remover, shaft of reverse immediate gear	Remove shaft of reverse immediate gear
0800-011000-922-001	Remover, left crankcase bearing	Remove bearing of left crankcase
0800-012000-922-001	Remover, right crankcase bearing 5206	Remove bearing 5206
0800-012101-921-001	Damper, right crankcase	Support right crankcase
0800-011101-921-001	Damper, left crankcase	Support left crankcase
0800-060000-922-001	Press tool, reverse immediate gear shaft	Press reverse immediate gear shaft
0180-014001-921-001	Press tool, left crankcase cover bearing 60/28	Press bearing 60/28
0180-013201-921-001	Press tool, CVT case cover bearing 6003	Press bearing 6003
0180-013207-923-001	Press tool, oil seal of CVT case cover	Press oil seal
0180-051000-922-001	Holding Wrench, CVT drive pulley	Stop rotation of drive pulley
0180-013101-921-002	Press tool, CVT case bearing 6207	Press bearing
0180-053100-921-002	Press tool, clutch housing	Press clutch housing
0180-053100-921-001	Damper, clutch housing	Support clutch housing when pressing clutch
0180-054000-922-001	Holding wrench, clutch	Stop clutch rotation
0110-080005-923-001	Press tool, oil seal of water pump	Install oil seal 10×20×5 of water pump
0010-081004-921-001	Press tool, water seal	Press water seal
0180-022006-922-001	Valve spring compressor clamp	Compress, remove valve spring
0180-060008-922-001	Wrench, circlip of front output shaft bearing	Install/Remove front output shaft bearing circlip
0180-062201-921-003	Press tool, driven bevel gear shaft bearing (6207C3)	Press bearing
0180-062103-921-002	Press tool, drive bevel gear shaft bearing (6305)	Press bearing
0010-060002-921-002	Installer, bearing 6203	Press bearing
0180-012100-921-004	Installer, bearing 3206A	Press bearing
0180-011100-921-004	Press tool, gearshift shaft bearing 6303	Press bearing
0040-012001-921-002	Press tool, bearing 6203	Press bearing

1 GENERAL INFORMATION

Lubricants and Service Products

Item	Type	Lubrication points	Remarks
Engine oil	SAE15W-40 API : SG or higher (Alternative please see page 1-6)	Cylinder,Crankcase,Cylinder head,see page (10-3)	
Molybdenum disulfide grease		Piston pin, valve stem, valve oil seal, camshaft	
Grease	No. 3 MoS ₂ grease	Oil seal, O-ring and other rubber seals. Sealed bearing, CVT bearing and bushing	
Coolant	-30°C Anti-freezing, anti-corrosive, high-boiling coolant	Engine cooling system	Coolant capacity depends on radiator pipes
Silicone sealant	Loctite5699	Crankcase splitting surfaces,contact surface between crankcase and cylinder,contact surface between cylinder head and valve cover	
Threadlocker	KB243	Some threads	
Retaining compound	KB648	Oil seal	

WIRING, PIPES & CABLES LOCATION

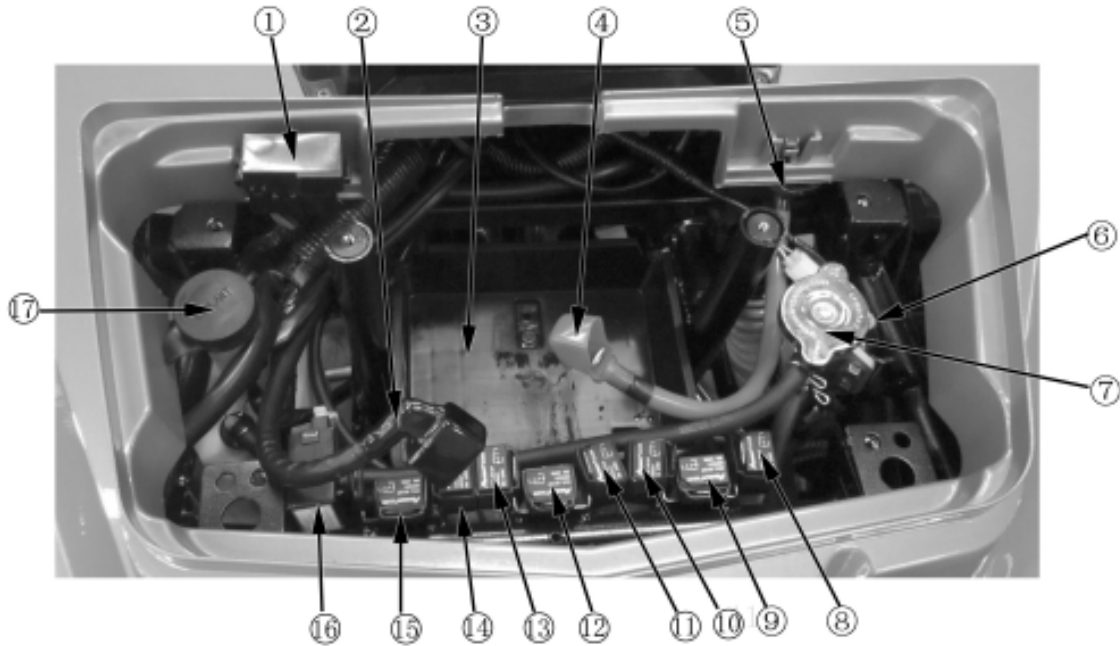

1. Fuse box 2. Negative cable, battery 3. Battery case 4. Positive cable, battery 5. Starter relay 6. PDA connector 7. Radiator cap 8. Relay of headlight 9. Fan relay 10. 2x4 drive relay 11. 4x4 drive lock relay 12. Relay of brake light 13. Relay of fuel pump 14. Starter auxiliary relay (1) 15. Starter auxiliary relay (2) 16. Flasher relay 17. Cap, reservoir tank

NOTE: Before check or repair above items, front top cover should be removed, but when check starter relay, it can be operated from upper part of front left wheel.

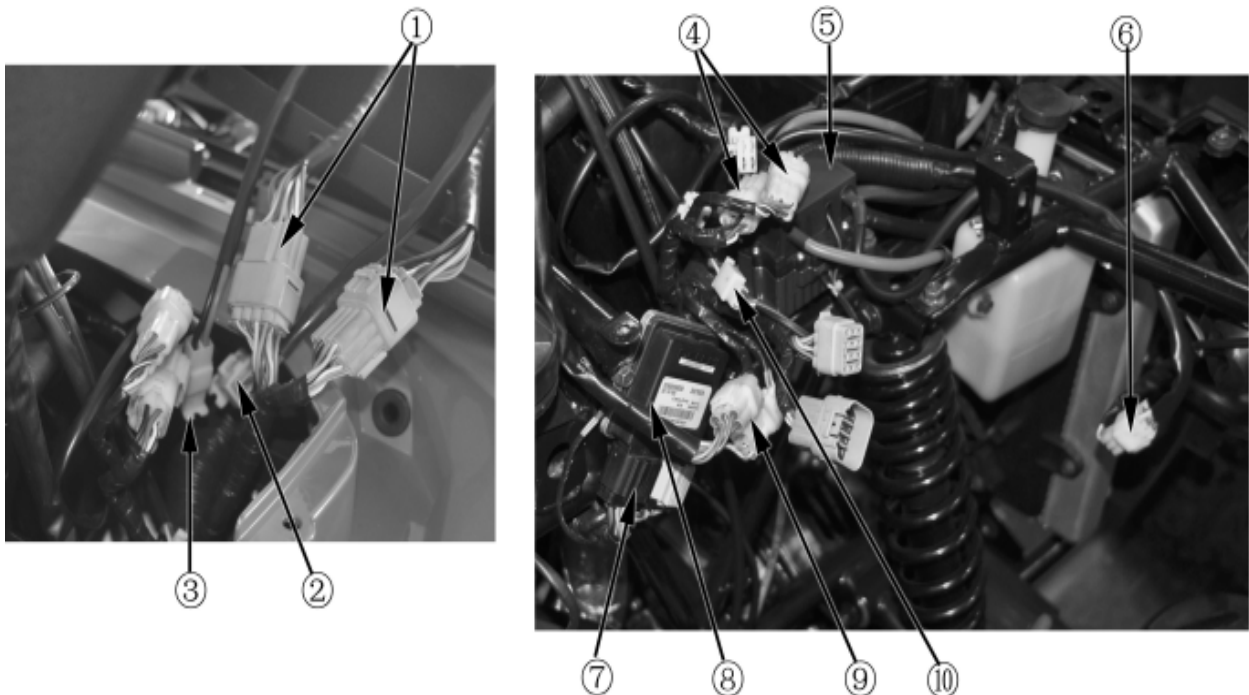

1. Dashboard connector 2. Connector of ignition switch 3. Connector, cigarette lighter 4. Connector, left handlebar switch 5. Winch control unit 6. Connector, right headlight 7. ECU connector 8. ECU 9. Connector, right handlebar switch 10. Connector, winch motor switch

Before checking above items, seat, front rack, left and right side panel, cover of air filter and front fender should be removed.

1 GENERAL INFORMATION

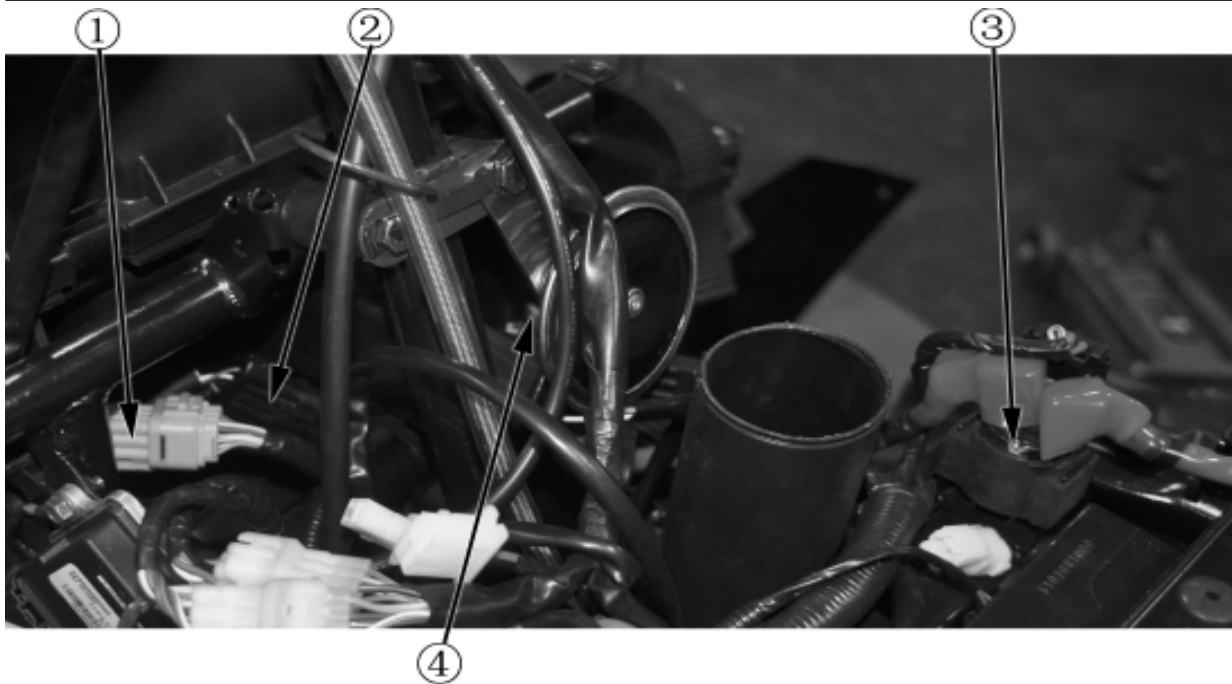

1.Connector, auxiliary cable 2.Connector1, oxygen sensor 3. Starter relay 4.Connector, horn

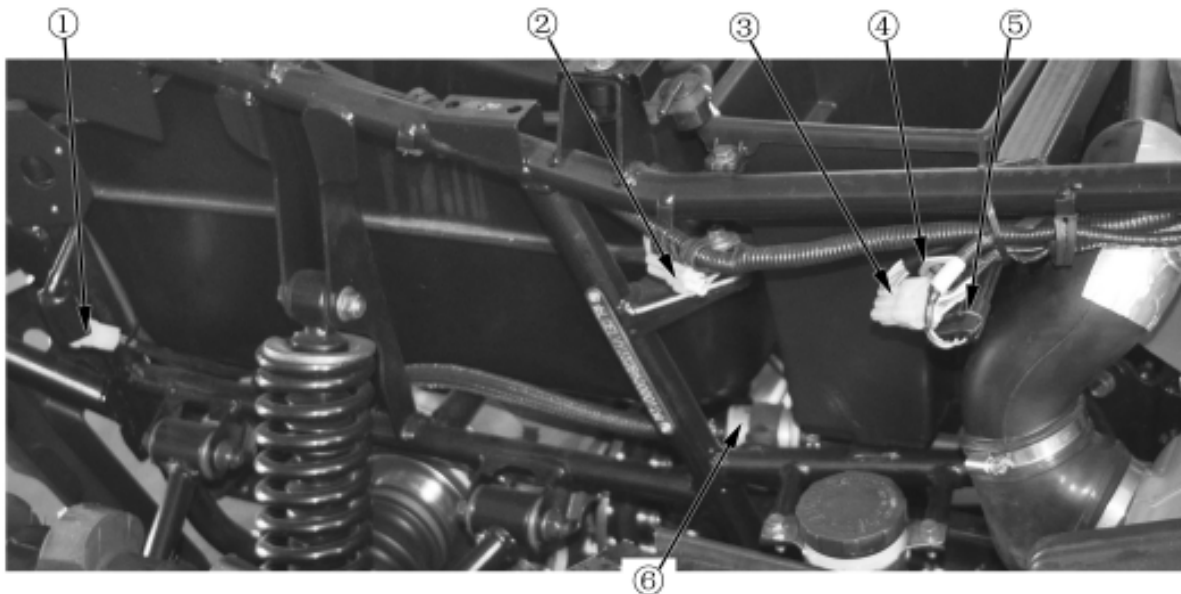

1.Connector, fuel pump 2.Connector, fuel sensor 3.Connector, gear sensor 4.Connector, rear brake switch 5. Connector 2, oxygen sensor 6. Fuel filter

Before checking and repair above items, left and right side panel, seat should be removed.

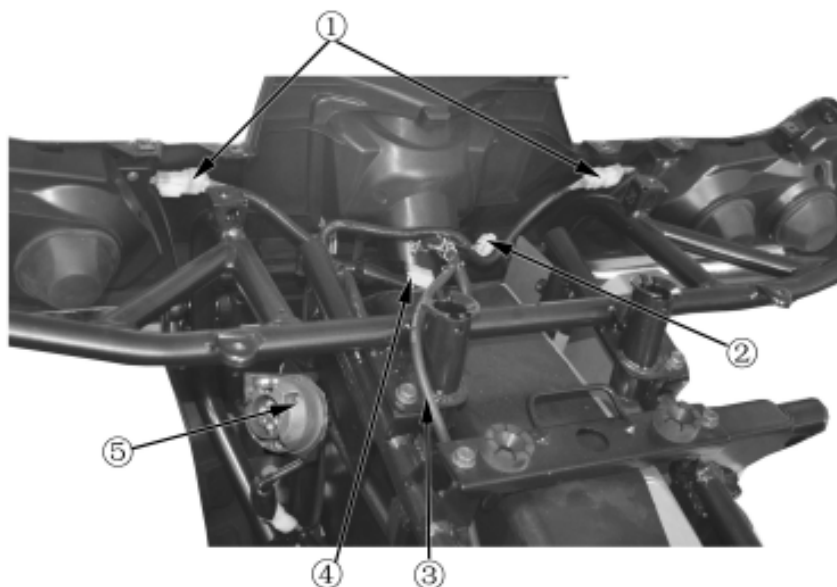

1.Connector,tail light/brake light/rear turn light 2.Connector, rear licence light 3.Breather hose, fuel evaporated system(Note:For Euro standard, ATV is without fuel evaporated system, so the breather hose is only for balancing pressure of fuel tank. It's important to avoid hose blocked, otherwise fuel pump will be damaged. At the same time, avoid to overfill fuel. 4.Connector, trailer power socket 5.Trailer power socket
Attention: Voltage of trailer power socket (DC12V) Max. current is less than 10A. The socket is only used for power supply for rear turn light of trailer, tail light and rear licence light.



1.Throttle cable 2.Connector, pick-up coil 3.Throttle body 4. TPS 5. Air by-pass valve 6. Injector 7. Water temp. sensor 8. Water pipe 9. Air intake temp. sensor 10. Ignition coil

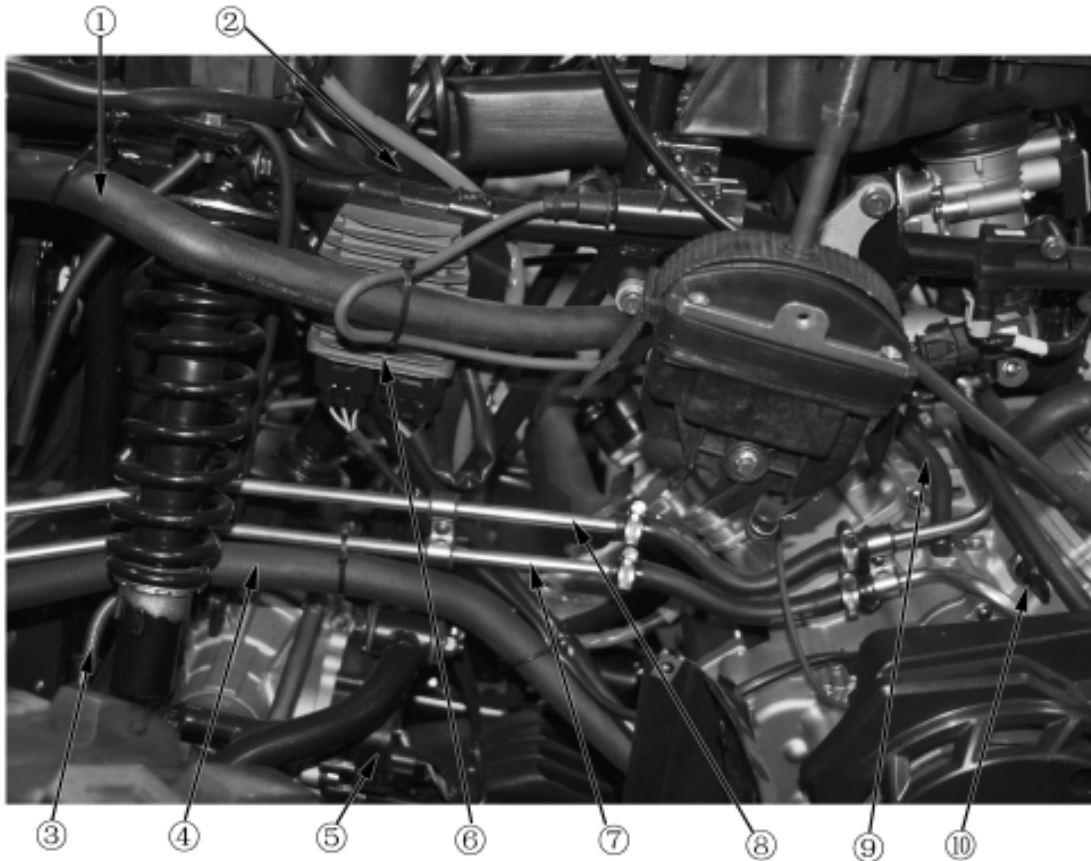

1. Water outlet pipe 2. Connector, differential gear motor 3. Brake hose 4. Water inlet pipe 5. Differential gear motor 6. Regulator 7. Oil inlet pipe 8. Oil outlet pipe 9. Exhaust gas pipe between crankcase and air filter 10. Oil pressure switch

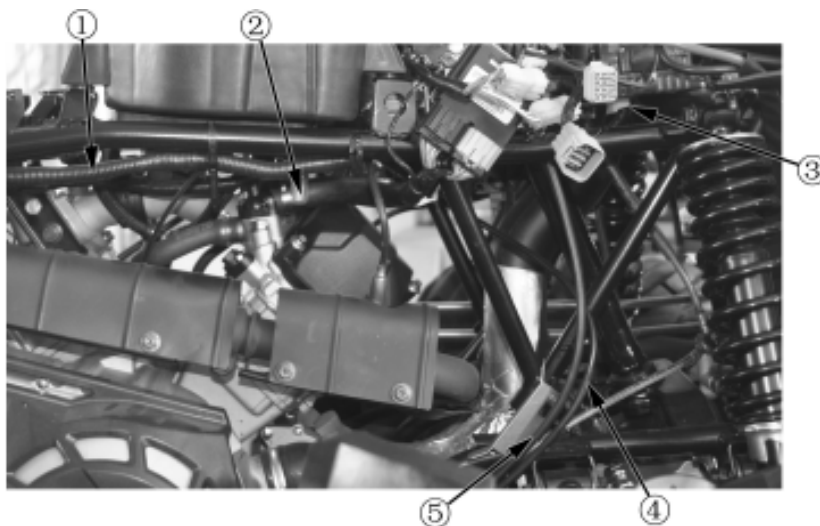

1. Main cable 2. Waste fuel collection hose 3. Connector, cooling fan 4. Limit cable, gearshift 5. Rear brake cable

MIL

MIL is located at ① position.

When the light flashes, it will indicate there's something wrong in vehicle. The flash code consists of 4 digits.

Example: 0650

“0” means flash 10 times;

“6” means flash 6 times;

“5” means flash 5 times;

“0” means flash 10 times.

Details please refer to page (15-27).

Also PDA can be used for diagnosis. please see page (1-19) and (15-26) to know “How to use PDA”.

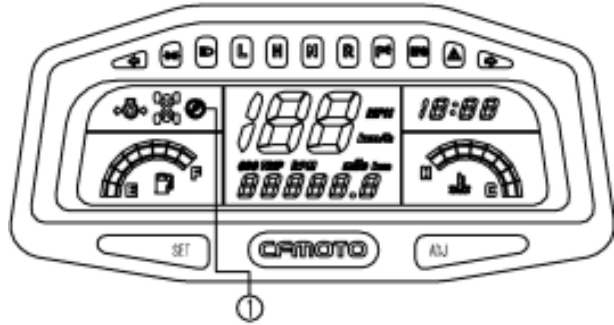

EVAP(Evaporative Emission Control System)

The system is only assembled for specified regions (such as USA california state). For European countries and other regions, it's not available.

If there is something wrong for EVAP, please contact local dealer for service. Do not modify the system without approval, otherwise it will not in accordance with related laws and regulations. After disassembling the system, check if fuel hoses are good, if any air or fuel leakage, if any blocked, if any damaged. Evaporative fuel goes into canister through disorption hose. When engine stops, carbon inside canister can adsorp evaporative fuel. When engine starts, fuel inside canister will go to combustion chamber through disorption hose to avoid going out to pollute air. Meanwhile adsorption hose can balance air pressure inside fuel tank to protect fuel tank and fuel pump.

Working Flow Layout:

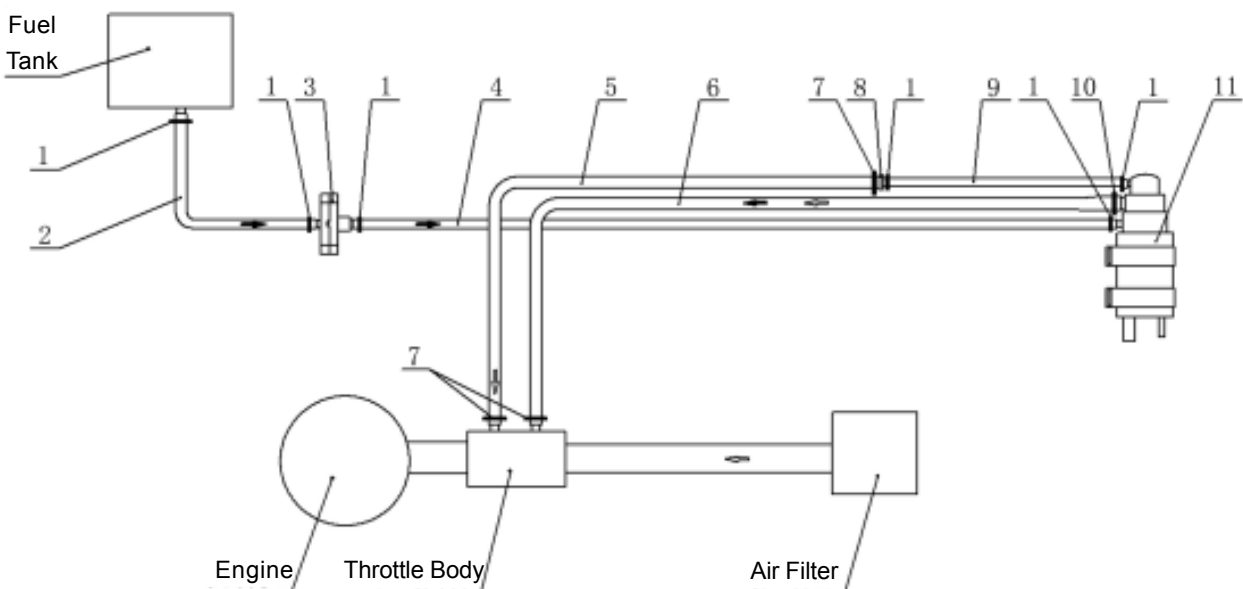

1. Clamp 2. Vacuum pipe of canister 3. Two way valve 4. Vacuum pipe (2) 5. Evaporative fuel pipe (2) 6. Evaporative fuel pipe (1) 7. Clamp 8. Water pipe joint 9. Evaporative fuel pipe (3) 10. Clamp 11. Canister

Maintenance Information.....	2-1	Rear Fender.....	2-10
Troubleshooting.....	2-1	LH Footboard,LH Headlight Protector..	2-11
Front Rack,Battery Cover.....	2-2	Rear LH Bumper Guard,Rear Bumper, Bumper Protector.....	2-12
Rear Rack.....	2-3	Front Bumper,Headlight trim.....	2-13
Passenger Seat,Driver Seat.....	2-4	Taillight Trim,Rear Fascia.....	2-14
Air Filter Cover,Dashboard Cover.....	2-5	Front LH Suspension Protector,	
Gearshift Lever Knob, Lever Indicator, LH Side Panel.....	2-6	Rear LH Suspension Protector.....	2-15
RH Side Panel,Front Fender Extension,LH..	2-7	Fuel Tank.....	2-16
Front Fender Extension,RH,		Muffler.....	2-17
Rear Fender Extension,LH.....	2-8	Body and Accessories.....	2-18
Center Front Fascia,Front Fender.....	2-9		

MAINTENANCE INFORMATION

Operation Cautions

WARNING:

Gasoline is highly flammable, therefore smoke and fire are strictly forbidden in the work place. Special attention should also be paid to sparks. Gasoline may also be explosive when it is vaporized, so operation should be done in a well-ventilated place.

Remove and Install muffler after it is fully cold.

- This chapter is on the disassembly and installation of rack, visible parts, exhaust pipe, muffler and fuel tank.
- Hoses, cables and wires should be routed properly.
- Replace the gasket with a new one after muffler is removed.
- After muffler is installed, check if there is any exhaust leakage.

Tightening Torque

Muffler Rear Fixing Bolt: 35-45N • m

Muffler Exhaust Pipe Bolt: 35-45N • m

Muffler Body Fixing Bolt: 35-45N • m

Troubleshooting

Loud exhaust noise

- Broken muffler
- Exhaust leakage

Insufficient power

- Deformed muffler
- Exhaust leakage
- Muffler clogged

BATTERY COVER

Removal

Pull strap no.1 toward dashboard cover to disengage the latch to remove battery cover no.2.

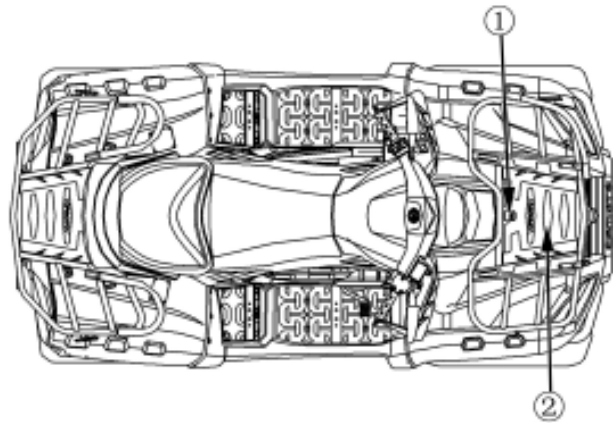

FRONT RACK

Removal

Remove battery cover;
Remove the 4 bolts no.4;

Remove front rack no.5.



Installation

Reverse the removal procedure for installation.

Tightening Torque :

Front rack mounting bolt no.4:

35N • m-45N • m

TOOL BOX COVER

Removal

Pull strap no.2 toward passenger seat to disengage the latch to remove tool box cover no.1.

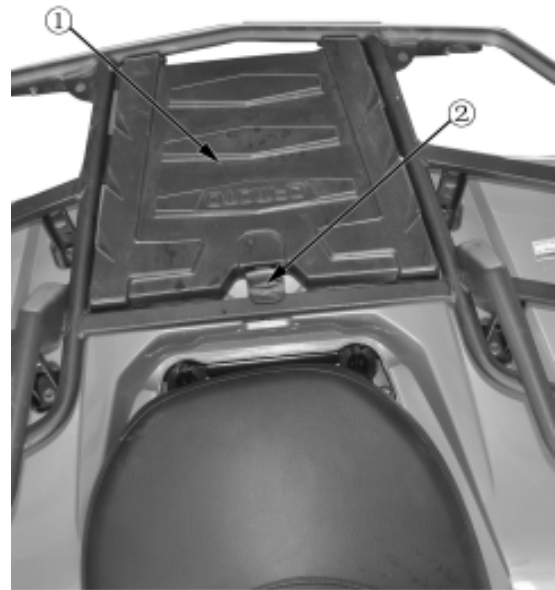

REAR RACK

Removal

Remove the 4 bolts no.3;
Remove rear rack no.4.

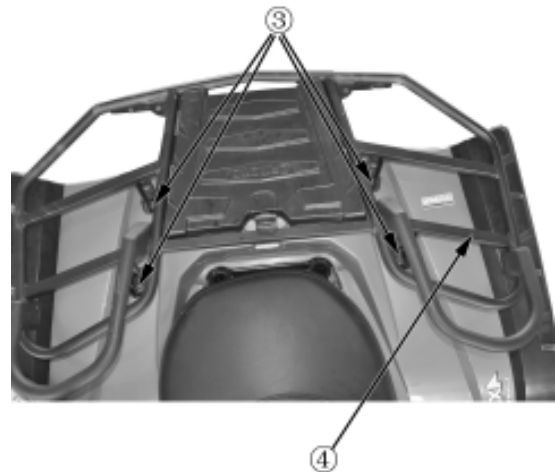

Installation

Reverse the removal procedure for installation.

Tightening Torque:

Rear rack mounting bolt no.3:
35N • m-45N • m

PASSENGER SEAT

Removal

Pull upward strap no.2 and lift passenger seat back to remove passenger seat no.1.

Installation

Reverse the removal procedure for installation.



DRIVER SEAT

Removal

Remove passenger seat;
Disengage driver seat latch no.4;
Remove driver seat no.3.

Installation

Reverse the removal procedure for installation.
Check if the driver seat is secured and in place after installation.

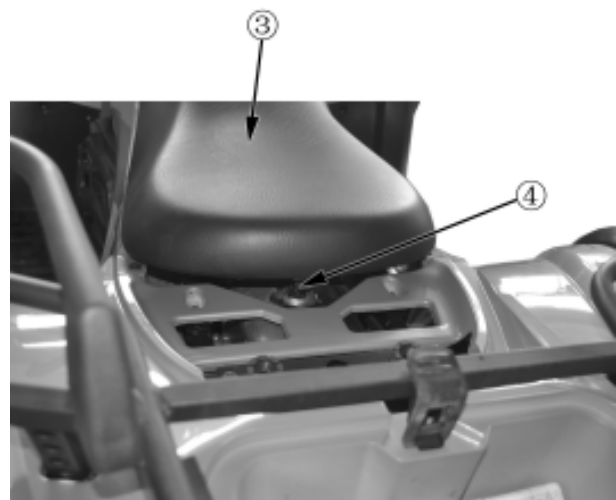

AIR FILTER COVER

Removal

Remove passenger seat(→2-4);

Remove driver seat(→2-4);

Lift the rear of air filter cover no.1 to disengage plastic latches then pull the air filter cover backward to remove it.

Installation

Reverse the removal procedure for installation.



DASHBOARD COVER

Remove passenger seat set(→2-4);

Remove driver seat(→2-4);

Remove air filter cover(→2-5);

Remove push rivets no.4;

Remove tapping screws no.3;

Remove dashboard cover no.2;

Unplug dashboard connectors no.5;

Unplug cigarette lighter connector no.6;

Unplug ignition switch connector no.7.

Installation

Reverse the removal procedure and direction for installation.

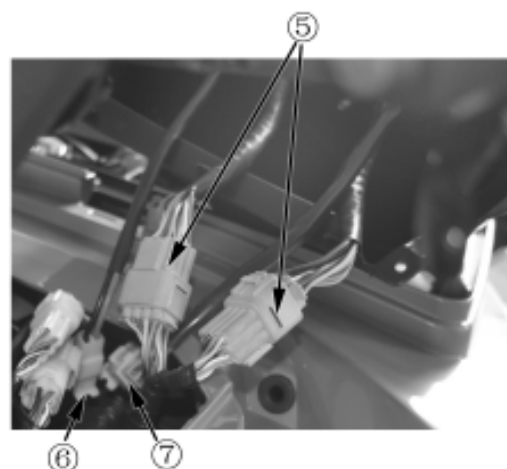

GEARSHIFT LEVER KNOB

Removal

Loosen locking nut no.2;
Remove gearshift lever knob by turning it counterclockwise.

Installation

Reverse the removal procedure and direction for installation.

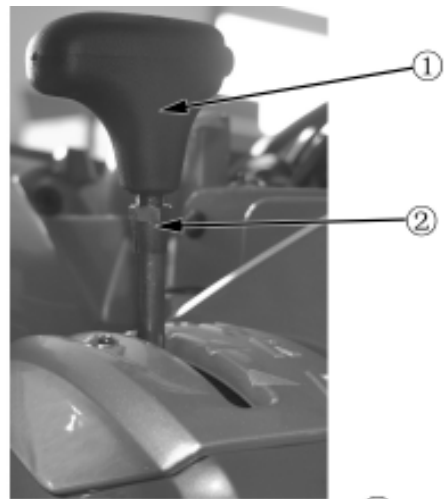

GEARSHIFT LEVER INDICATOR

Removal

Remove gearshift lever knob;
Remove screw no.4;
Remove lever indicator no.3.

Installation

Reverse the removal procedure and direction for installation.

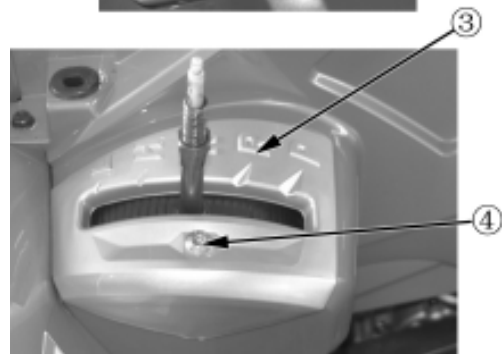

LH SIDE PANEL

Removal

Remove passenger seat set(→2-4);
Remove driver seat(→2-4);
Remove air filter cover(→2-5) ;
Remove gearshift lever knob ;
Remove lever indicator;
Remove push rivets no.5;
Remove bolts no.6;
Remove tapping screws no.8 retaining front and rear fender;
Remove latch no.9;
Remove side panel.

Installation

Reverse the removal procedure and direction for installation.

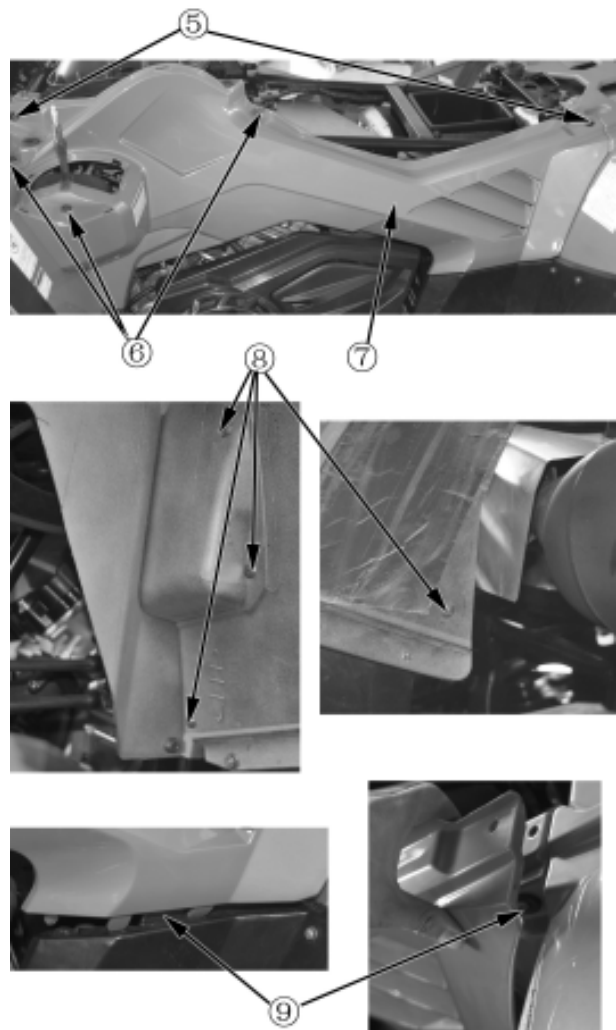

RH SIDE PANEL

Removal

- Remove passenger seat(→2-4);
- Remove driver seat(→2-4);
- Remove air filter cover(→2-5);
- Remove push rivets no.1;
- Remove bolts no.2;
- Remove tapping screws no.4;
- Remove push rivets no.5;
- Remove RH side panel.

Installation

Reverse the removal procedure and direction for installation.

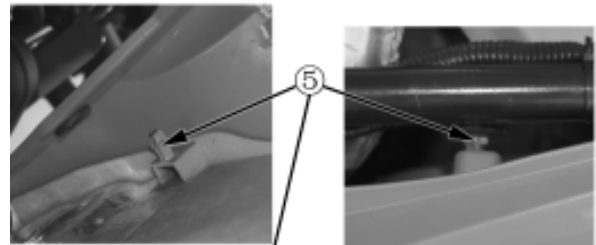
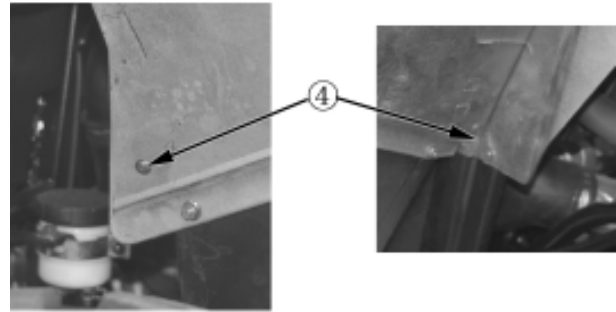
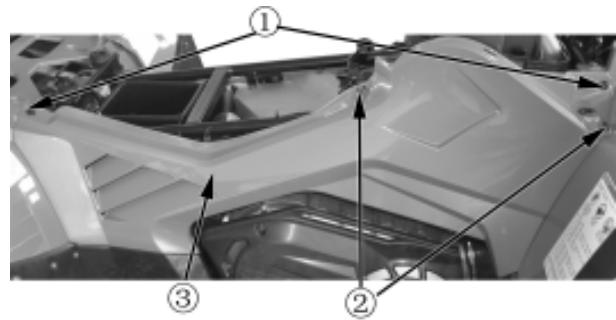

FRONT FENDER EXTENSION,LH

Removal

- Remove bolts&nuts no.8;
- Remove push rivet no.7;
- Disengage plastic latches;
- Remove front LH fender extension no.6.

Installation

Reverse the removal procedure and direction for installation.

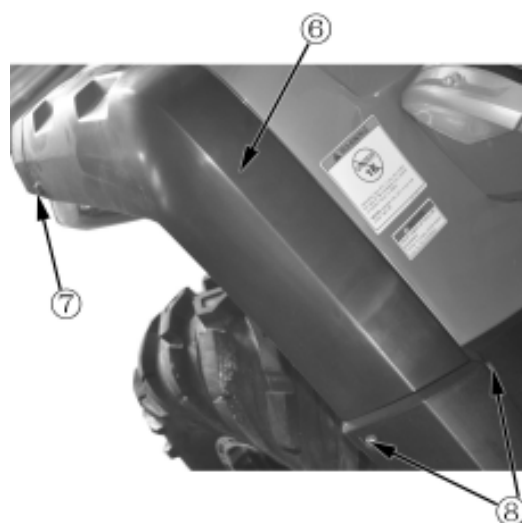

FRONT FENDER EXTENSION,RH

Removal

Remove bolts&nuts no.3;

Remove push rivet no.2;

Disengage plastic latches;

Remove front RH fender extension no.1.

Installation

Reverse the removal procedure and direction for installation.



REAR FENDER EXTENSION,LH

Removal

Remove push rivets no.5;

Remove bolts&nuts no.6;

Remove tapping screw no.7;

Disengage plastic latches;

Remove rear fender extension,LH no.4.

Installation

Reverse the removal procedure and direction for installation.

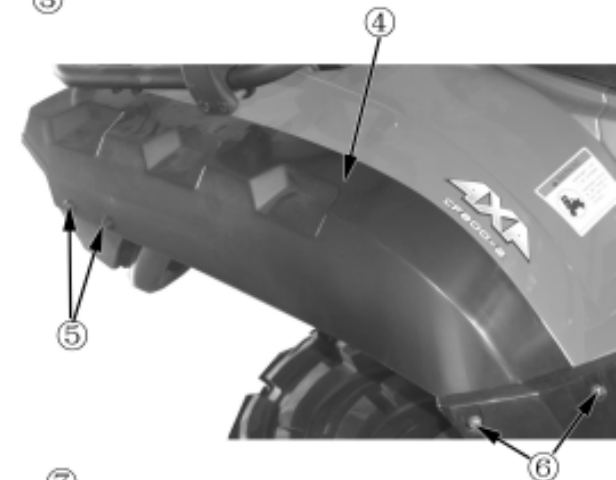

REAR FENDER EXTENSION,RH

Refer to rear *LH Fender Extension Removal&Installation.*



CENTER FRONT FASCIA

Removal

Remove the 2 tapping screws no.2;
 Remove push rivets no 3;
 Remove center front fascia.

Installation

Reverse the removal procedure for installation.

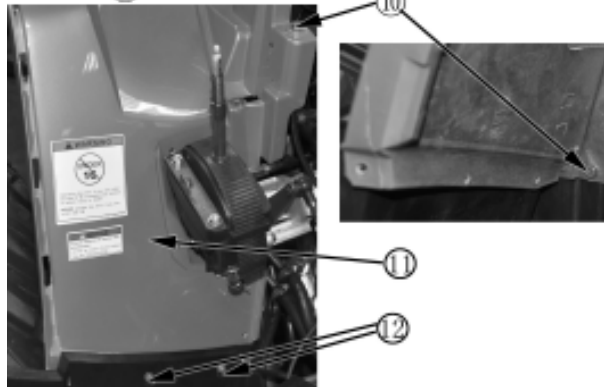
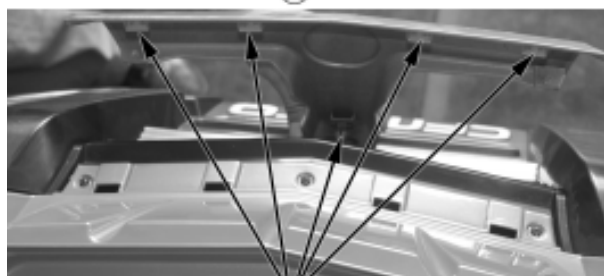
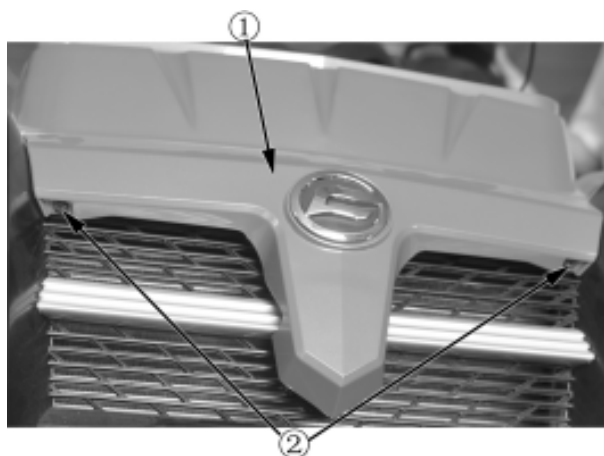

FRONT FENDER

Removal

Remove front rack(→2-2);
 Remove passenger seat(→2-4);
 Remove operator seat(→2-4);
 Remove air filter cover(→2-5);
 Remove dashboard front cover(→2-5);
 Remove gearshift lever knob(→2-6);
 Remove lever indicator(→2-6);
 Remove front LH&RH fender extension(→2-7);
 Remove L&R side panel(→2-7);
 Remove front center fascia;
 Remove push rivets no.5&7;
 Remove bolts no.4;
 Remove tapping screws no.6;
 Remove bolts no.8;
 Remove bolts no.9;
 Remove bolts no.10;
 Remove bolts no.12;
 Remove fuse box;
 Remove front fender no.11.

Installation

Reverse the removal procedure for installation.

Rear Fender

Removal

- Remove rear rack(→2-3);
- Remove passenger seat(→2-4);
- Remove driver seat(→2-4);
- Remove air filter cover(→2-5) ;
- Remove rear LH&RH side panel(→2-8);
- Remove LH&RH side panel(→2-6);
- Remove tapping screws no.1;
- Remove push rivets no.2;
- Remove bolt no.4;
- Remove tapping screws no.5;
- Remove bolt no.6;
- Remove bolt no.7;
- Remove bolts no.8;
- Remove rear fender no.3.

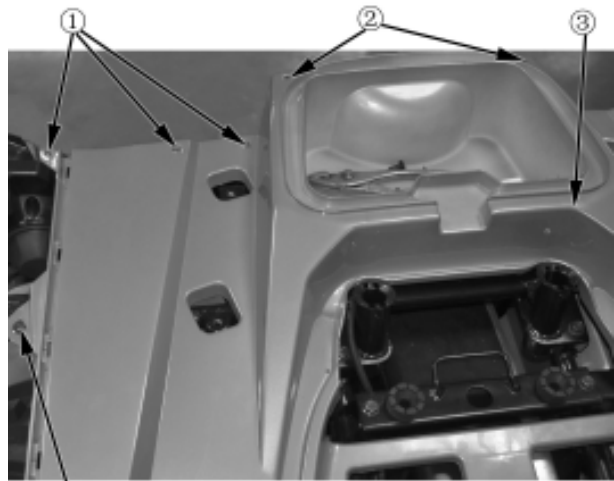

Installation

Reverse the removal procedure for installation.

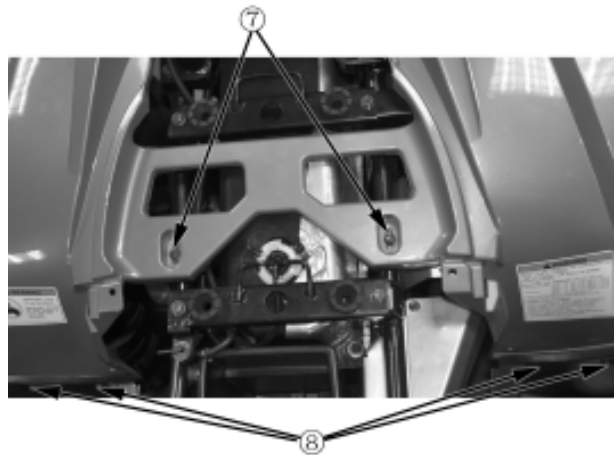

LH FOOTBOARD

Removal

- Remove passenger seat(→2-4);
- Remove driver seat(→2-4);
- Remove air filter cover(→2-5);
- Remove side panel(→2-6);
- Remove the bolts,nuts retaining front and rear mudguard;
- Remove bolts no.1;
- Remove screws no.1;
- Remove LH footboard no.2.

Installation

Reverse the removal procedure for installation.

RH FOOTBOARD

Removal

- Remove gearshift lever knob(→2-6);
- Remove lever indicator(→2-6);
- Refer to *LH Footboard Removal&Installation.*

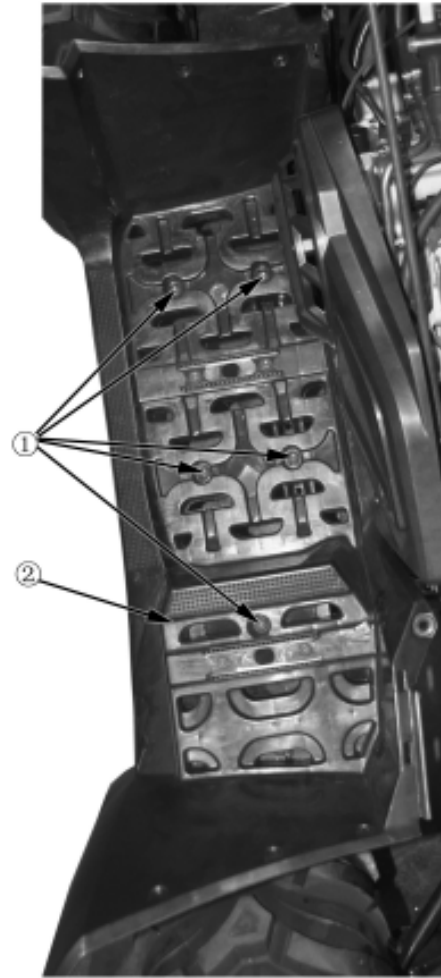

HEADLIGHT PROTECTOR,LH

Removal

- Remove bolts no.4;
- Remove headlight protector,LH.

Installation

Reverse the removal procedure for installation.

HEADLIGHT PROTECTOR,RH

Removal&Installation

Refer to *LH Headlight Protector Removal&Installation.*

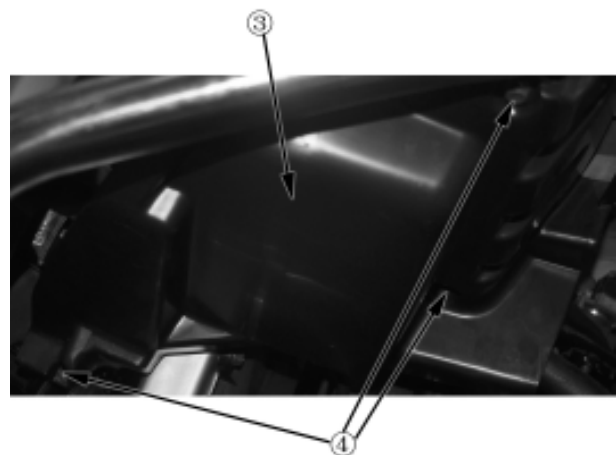

REAR BUMPER GUARD,LH

Removal

Remove bolt no.2;

Removal rear LH bumper guard no.2.

Installation

Reverse the removal procedure for installation.

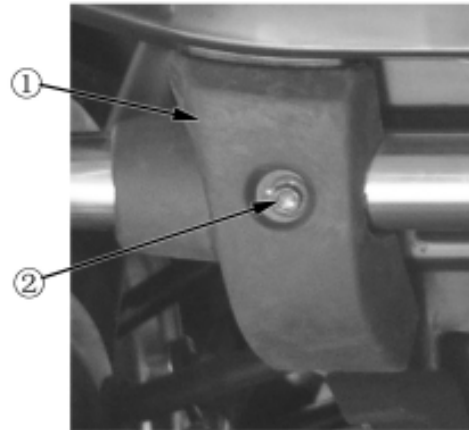

REAR BUMPER GUARD,RH

Removal&Installation

Refer to *Rear LH Bumper*

Guard Removal&Installation.

REAR BUMPER

Removal

Remove rear LH&RH bumper guard.

Remove bolt no.4;

Remove rear bumper no.3.

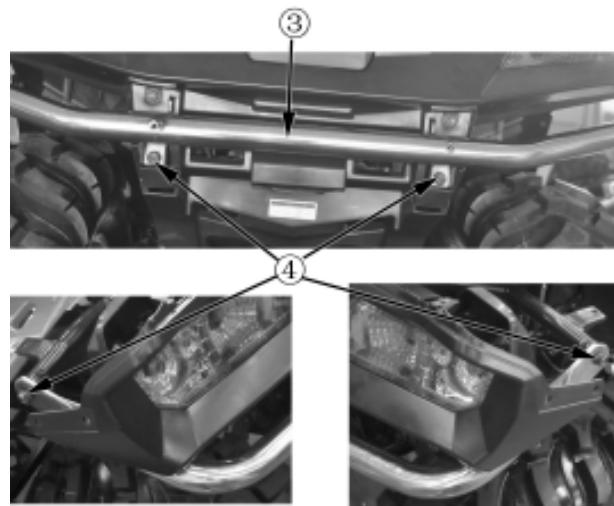

Installation

Reverse the removal procedure for installation.

FRONT BUMPER PROTECTOR

Removal

Remove bolt no.5;

Remove front bumper protector no.6.

Installation

Reverse the removal procedure for installation.

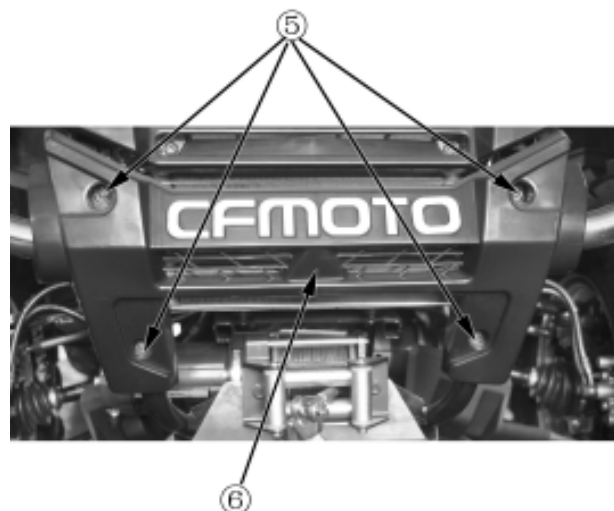

FRONT BUMPER

Removal

Remove front bumper protector(→2-12);

Remove bolt no.2;

Remove front bumper no.1.1

Installation

Reverse the removal procedure for installation.

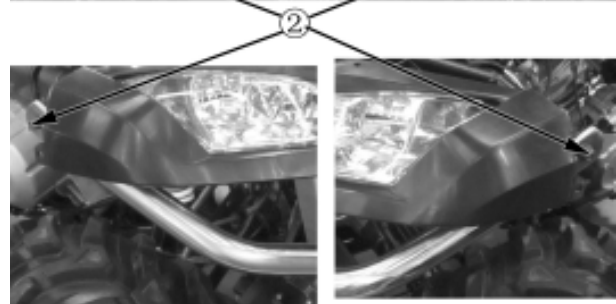
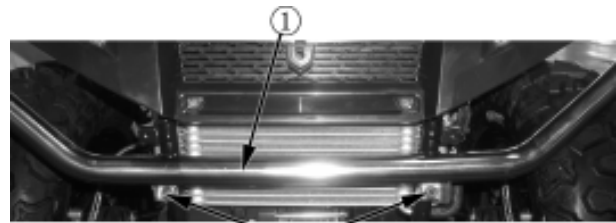

HEADLIGHT TRIM

Removal

Remove front rack(→2-2);

Remove passenger seat(→2-4);

Remove driver seat(→2-4);

Remove air filter cover(→2-5);

Remove dashboard cover(→2-5);

Remove font LH&RH fender extension(→2-7);

Remove LH&RH side panel(→2-6);

Remove center front fascia(→2-9);

Remove front fender(→2-9);

Remove bolts no.4;

Remove bolts no.5;

Disconnect headlight connectors;

Remove headlight trim no.3.

Installation

Reverse the removal procedure for installation.

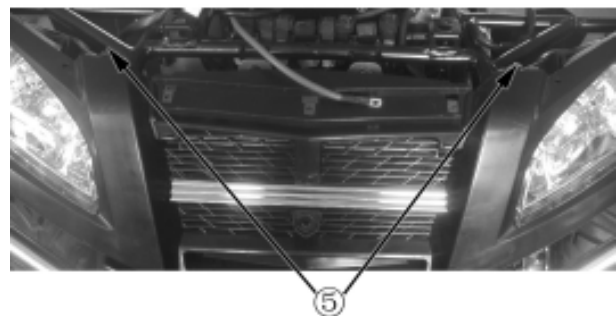
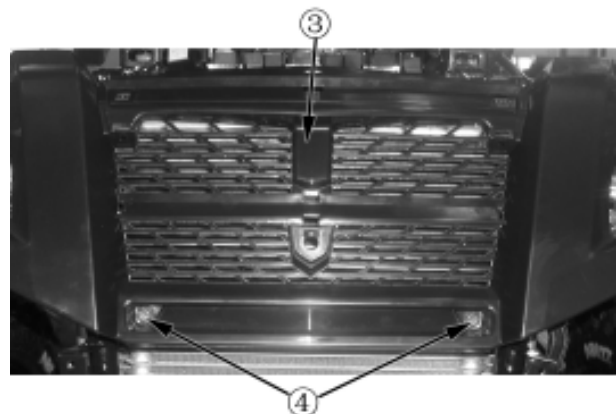

TAILLIGHT TRIM

Removal

- Remove rear rack(→2-3);
- Remove passenger seat(→2-4);
- Remove operator seat(→2-4);
- Remove air filter cover(→2-5);
- Remove rear LH&RH fender extension(→2-8);
- Remove LH&RH side panel(→2-6);
- Remove rear mudguard(→2-10);
- Remove rear LH&RH bumper guard(→2-12);
- Remove rear bumper(→2-12);
- Remove bolts no.2;
- Disconnect tail light,license plate light,rear turn lights connectors;
- Remove taillight trim no.1.

Installation

Reverse the removal procedure for installation.

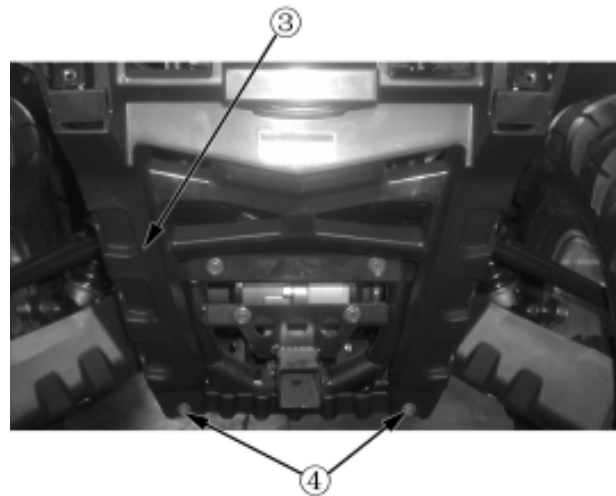
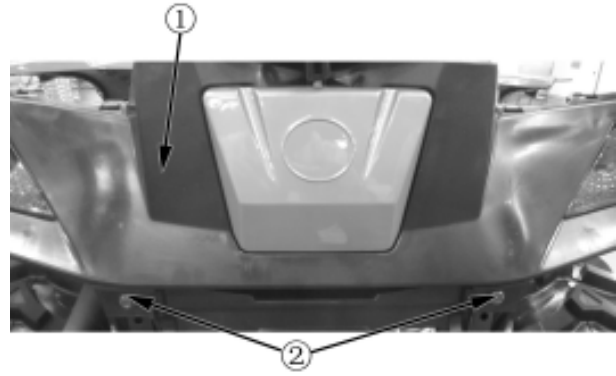

REAR FASCIA

Removal

- Remove rear LH&RH bumper guard(→2-12);
- Remove rear bumper(→2-12);
- Remove bolts of taillight trim;
- Remove bolts no.4;
- Remove rear fascia no.3.

Installation

Reverse the removal procedure for installation.

LH PROTECTOR,FRONT SUSPENSION

Removal

Remove bolt no.1;

Remove LH protector no.2.

Installation

Reverse the removal procedure for installation.



RH PROTECTOR,FRONT SUSPENSION

Refer to *LH Protector,Front Suspension Removal&Installation.*

RH PROTECTOR,REAR SUSPENSION

Removal

Remove bolt no.3;

Remove bolt no.4;

Remove LH protector no.5.

Installation

Reverse the removal procedure for installation.

LH PROTECTOR,FRONT SUSPENSION

Refer to *RH Protector,Rear Suspension Removal&Installation.*

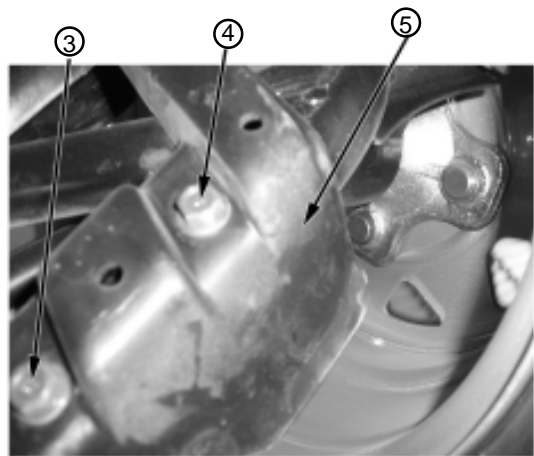

FUEL TANK

Removal

WARNING:

Gasoline is highly flammable, therefore smoke and fire are strictly forbidden in the work place.

Special attention should also be paid to sparks. Gasoline may also be explosive when it is vaporized, so operation should be done in a well-ventilated place.

Remove passenger seat set(→2-4);

Remove driver seat(→2-4);

Remove bolts no.4;

Remove push rivets no.1;

Remove bolts no.2;

Remove bolts no.6;

Remove bolts no.7;

Remove rear plastic parts;

Disconnect fuel pump connector;

Unplug high pressure fuel line connector;

Remove fuel tank breather hose and hoses of fuel evaporation control system;

Disconnect fuel pump connector;

Remove bolts no.5;

Remove bolts no.9;

Remove fuel tank no.8.

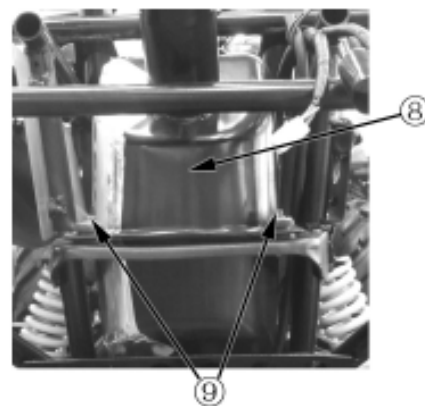
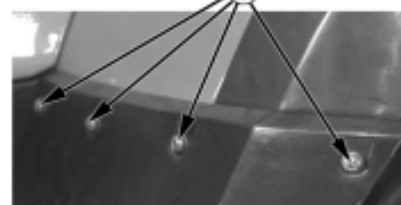
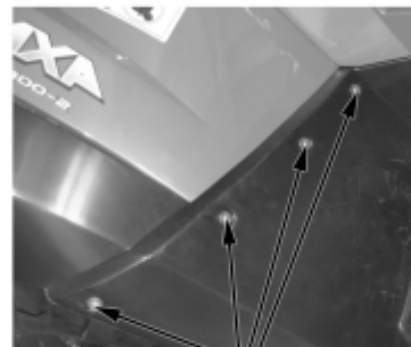
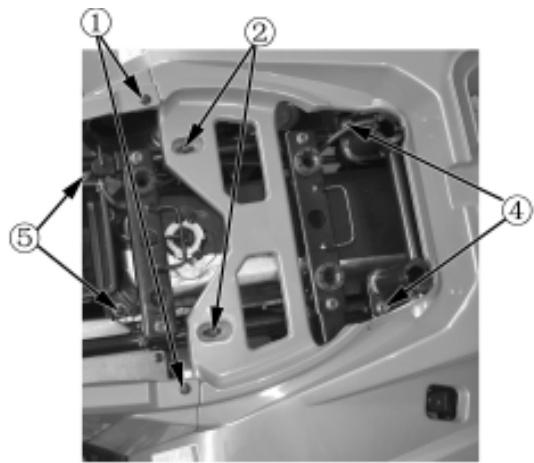

MUFFLER

WARNING:

Remove and Install muffler after it is fully cold.

Removal

Remove passenger seat set(→2-4);

Remove operator seat(→2-4);

Remove air filter cover(→2-5);

Remove RH side panel(→2-7);

Remove LH side panel(→2-6);

Remove bolts&nuts no.2;

Remove heat shield no.1;

Remove bolts&nuts no.4;

Remove heat shield no.3;

Remove bolts no.7;

Remove heat shield no.6.

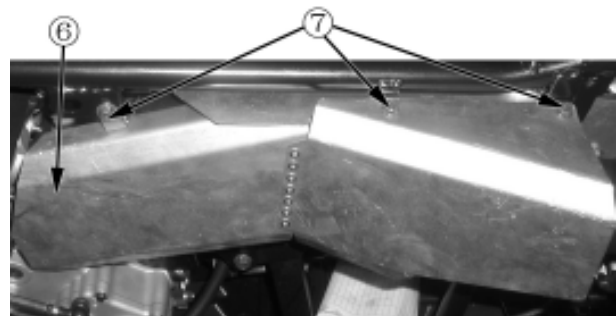
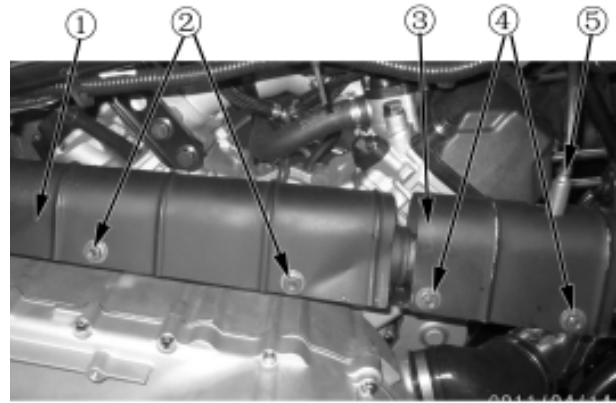

Remove bolts no.9;

Remove heat shield no.8;

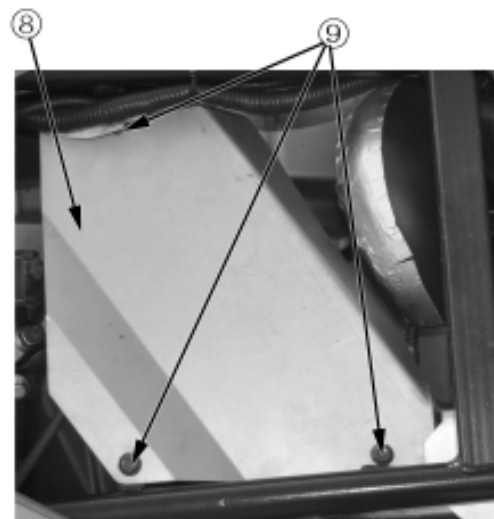

Remove bolt no.10 and the clamp;



Installation

Reverse the removal procedure for installation.

NOTE:

Replace the gasket on the exhaust port when installing.

Remove exhaust pipe bolts no.2;
Remove the exhaust pipe comp.no.1 of the front
cylinder;

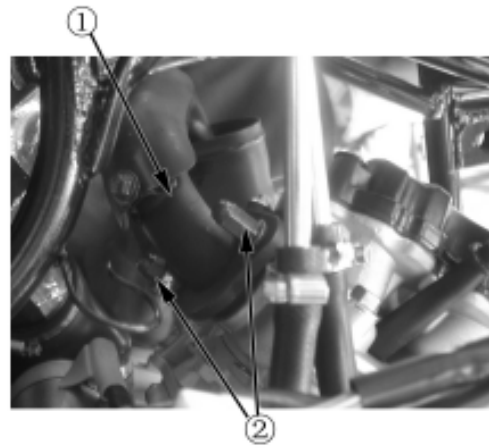

Remove exhaust pipe bolts no.3;
Remove "Y" exhaust pipe comp. no.4;

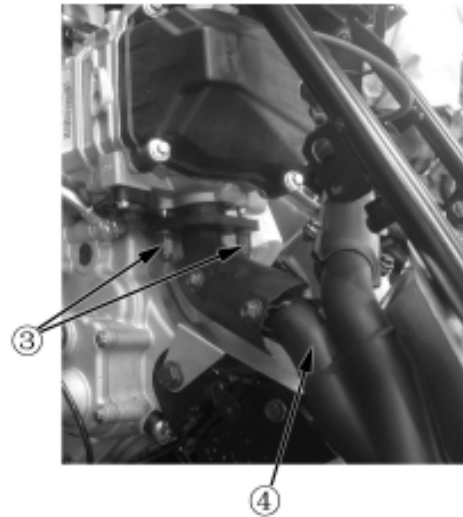

Remove spring no.5;
Remove bolt no.6;
Remove muffler no.7.

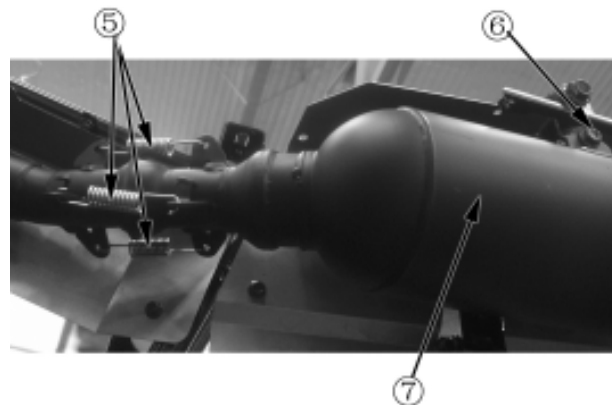

Installation

Reverse the removal procedure for installation.

NOTE:

*When installing, replace the gasket on exhaust port
and graphite collar in front exhaust pipe comp..*

BODY AND ACCESSORIES

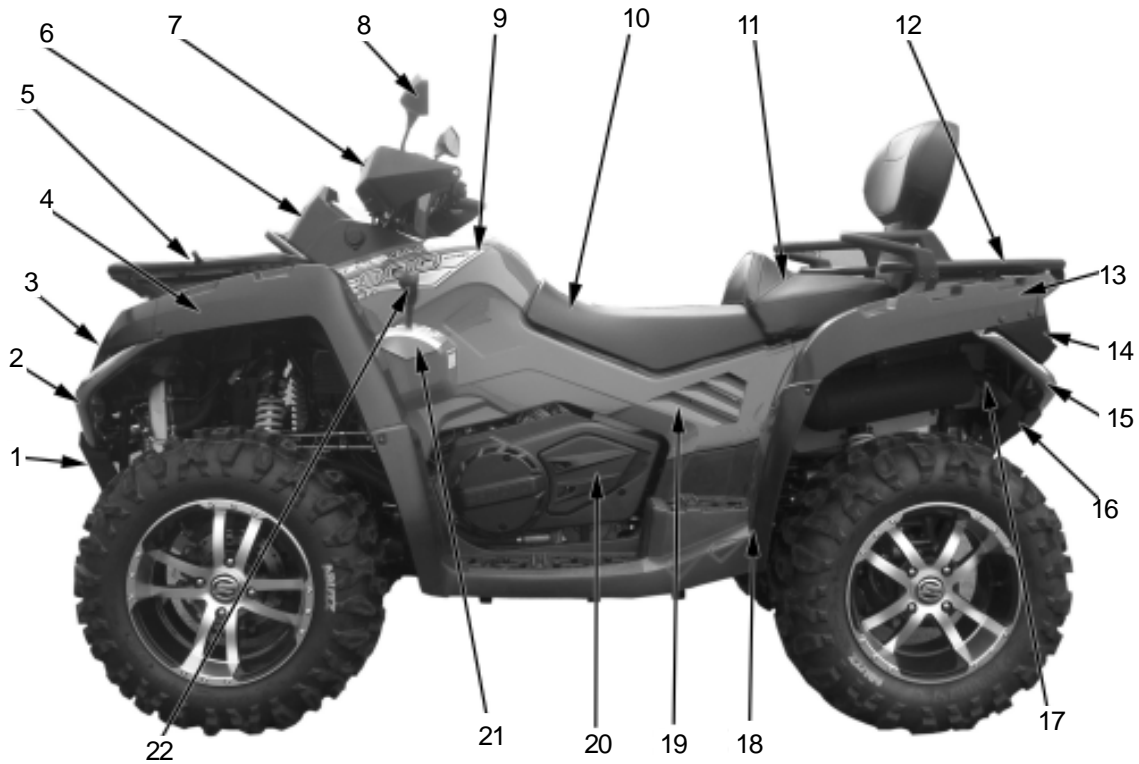

- | | | | |
|------------------------------|-------------------------|-------------------|-----------------------------|
| 1.Protector,Front Bumper | 2.Front Bumper | 3.Headlight Trim | 4.Front Fender Extension,LH |
| 5.Front Rack | 6.Dashboard Cover | 7.LH Handguard | 8.LH Mirror |
| 9.Air Filter Cover | 10.Driver Seat | 11.Passenger Seat | 12.Rear Rack |
| 13.Rear Fender Extension,LH | 14.Taillight Trim | 15.Rear Bumper | 16.Rear Fascia |
| 17.Spark Arrester | 18.LH Footboard | 19.LH Side Panel | 20.Oil Check Access Cover |
| 21.Gearshift Lever Indicator | 22.Gearshift Lever Knob | | |

Maintenance Information.....	3-1	Suspension System.....	3-11
Maintenance Interval.....	3-2	Gearshift Linkage, Fuel System.....	3-12
Maintenance Procedure.....	3-3	Throttle Lever.....	3-13
Steering Column, Brake System....	3-6	Cooling System.....	3-14
Wheel.....	3-9	Lighting System.....	3-16

MAINTENANCE INFORMATION

Operation Cautions

WARNING:

- Engine exhaust contains poisonous carbon monoxide and can cause loss of consciousness resulting in severe injury or death. Never run an engine in an enclosed area.
- Don't perform the maintenance immediately after the engine stops, as the exhaust system and engine become very hot. Serious burns could result from the contact with the exhaust system or engine. Wear long-sleeved uniform and gloves to operate when necessary.
- Gasoline is highly flammable, therefore smoke and fire are strictly forbidden in the work place. Special attention should also be paid to sparks. Gasoline may also be explosive when it is vaporized, so operation should be done in a well-ventilated place.
- Don't get pinched by the drive system and other rotational parts.

ATTENTION:

Always position the vehicle on level ground.

3 INSPECTION AND ADJUSTMENT

Maintenance Intervals

Careful periodic maintenance will assure your vehicle good performance, reliability, economy and durability. Inspection, adjustment, lubrication and other details are explained in below periodic maintenance chart.

ATTENTION: Maintenance intervals in the following chart are based upon average riding conditions. Vehicles subjected to severe use must be inspected and serviced more frequently.

A: Adjust C: Clean I: Inspect L: Lubricate R: Replace	10 hours or 300km					
	Every 25 hours or 750km					
	Every 50 hours or 1500km					
	Every 100 hours or 3000km or 1 year					
	Every 200 hours or 6000km or 2 years					
Remark						
Engine						
Engine Oil and Filter	R			R		
Valve Clearance	I, A			I, A		
Condition of Engine Seals	I			I		
Engine Mounting Fasteners	I			I		
Air Filter		C	R			
Coolant	I		I	I	R	
Radiator Cap, Cooling System Pressure Test	I				I	
Spark Plug				I	R	
Fuel System						
Throttle Body	I			I, L		
CVT						
CVT Belt			I	R		
Primary Pulley, Driven pulley				I, C		
Clutch				I		

3 INSPECTION AND ADJUSTMENT

O: Maintenance Interval

Task	Inspection Item	Maintenance Interval			Criteria
		Daily	Every 6 Months	Yearly	
Handlebar	Agility	O			
Steering System	Damage	O			
	Installing condition	O			
	Free play of ball joint pin	O			
Brake Lever	Free play	O	O		Front brake lever:0mm Main brake(FR&RR) lever: 0mm
	Braking performance	O	O		
Brake lines&fittings	Looseness&damage	O		O	
Brake System	FR&RR brake fluid level	O	O		Brake fluid should be between "LOWER" and "UPPER"
	Brakedisc&pads wear&damage.	O	O		If front brake disc thickness is less than 2.5mm or rear brake disc thickness is less than 6.5mm,replace the disc.
Wheel	Tire pressure	O	O		Front tire:45kP (0.450kgf/cm ²) Rear tire:45kPa (0.45kgf/cm ²)
	Crack&damage	O		O	
	Tread depth&abnormal wear	O		O	Tread depth should be more than 3.0mm.
	Looseness of wheel nuts&axle	O	O		
	FR wheel bearing free play	O		O	
	RR wheel bearing free play	O		O	
A-arm	Free play&damage	O		O	
Shock	Leaks or damages	O		O	
FR Diff	Leaks&lubrication	O		O	
RR Gearcase	Leaks&lubrication	O		O	
Gearcase/Diff	Leaks&oil level	O		O	Keep the oil level even with the bottom threads of fill plug hole.

3 INSPECTION AND ADJUSTMENT

Maintenance Item		Maintenance Interval			Criteria
Task	Inspection Item	Daily	Every 6 Months	Yearly	
Propshaft	Looseness of connection	○	○		
	Free play of splines			○	
Ignition	Spark plug condition		○		Spark plug clearance: 0.8—0.9mm
	Timing		○		
Battery	Connections of terminals			○	
Electric Routing	Looseness&damages of connections			○	
Fuel System	Fuel leakage		○		
	Throttle condition			○	Throttle lever free play: 3—5mm
Cooling	Coolant level	○	○		
	Leaks			○	

3 INSPECTION AND ADJUSTMENT

Maintenance Item		Maintenance Interval			Criteria
Task	Inspection Item	Daily	Every 6 Months	Yearly	
Lights&Turn Signal Indicators	Function	○	○		
Alarming&locking Components	Function			○	
Meters	Function			○	
Exhaust Pipe&Muffler	Looseness&damages			○	
	Muffler function			○	
Frame	Looseness&damages			○	
	Lubrication			○	
Others	Abnormal conditions	○			

STEERING COLUMN

Position the vehicle on level ground. Put your hands on the grips and shake the handlebar in the direction illustrated in the right figure to check for free play.

If there is a free play, determine the source of it.

If the free play comes from steering column, tighten the steering column locking nut or remove steering column for further inspection and repair.

Position the vehicle on level ground. Turn the handlebars slowly to left or right to check for agility.

If the handlebars feel rough when turning somewhere, inspect the wiring, cables or tie-rod ends for interference. If no interference, check the steering bearing for damages.

WARNING:

Inspect the agility of handlebars before every ride. Steering failure may result in severe injury or death.

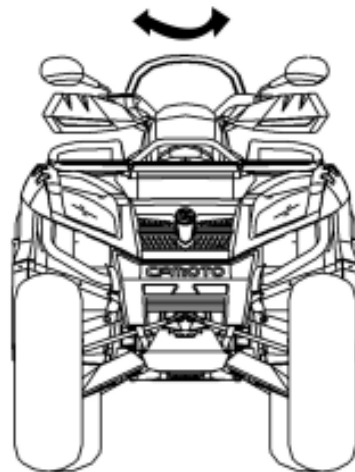
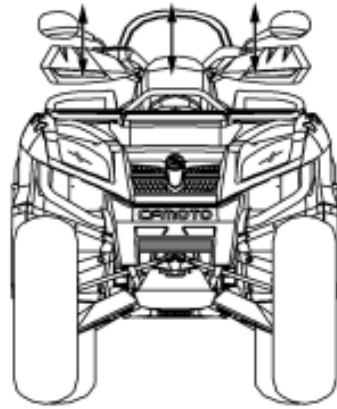

BRAKE SYSTEM

Front Brake Lever Free Play

Check the free play of front brake lever and the performance of front brake.

Free play of front brake lever: 0mm

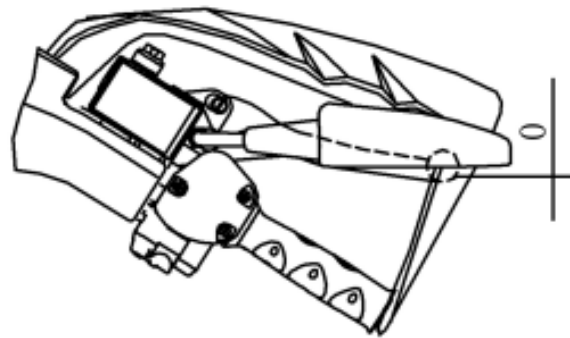

MASTER CYLINDER,FRONT BRAKE

<Brake Fluid Level>

Check brake fluid level.

If the brake fluid level is below the mark "Lower", check master cylinder, brake lines and connections for leaks. Remove the 2 retaining screws no.3 to open the reservoir cap.

Add DOT 3 or DOT 4 brake fluid only. Never exceed the mark no.1.

- When adding brake fluid, always avoid dirt or water.
- Always use specified brake fluid.
- Don't spill brake fluid on plastic or rubber parts, as it would damage them.
- Turn handlebar to left or right to keep the master cylinder level before the reservoir cap removal.

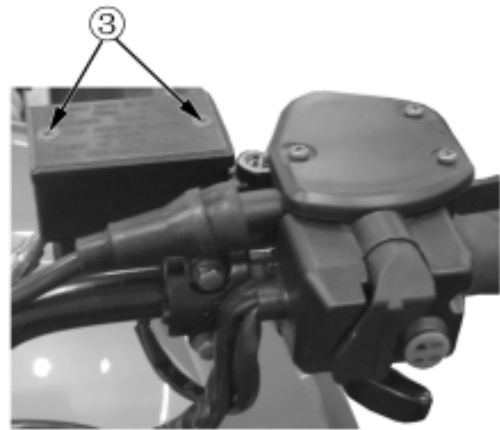
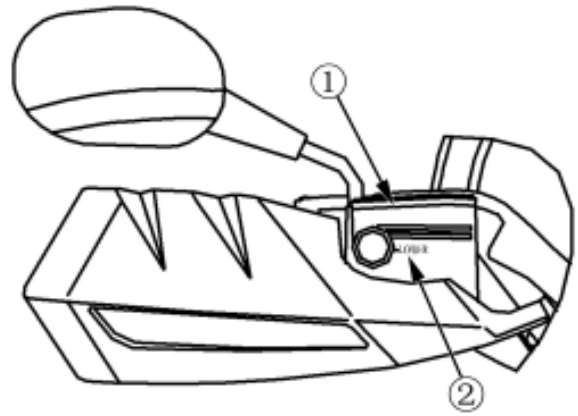

FRONT BRAKE DISC&BRAKE PADS

<Brake Pad Wear>

Inspect brake pads from the marked place.

Replace brake pads if they are worn to service limit groove.

CAUTION:

Pads should be replaced as an assembly.

Brake Disc Inspection&Replacement

Inspect brake disc for excessive wear or damage. Replace brake disc when its thickness is less than 2.5mm.

Front brake disc service limit thickness:2.5mm

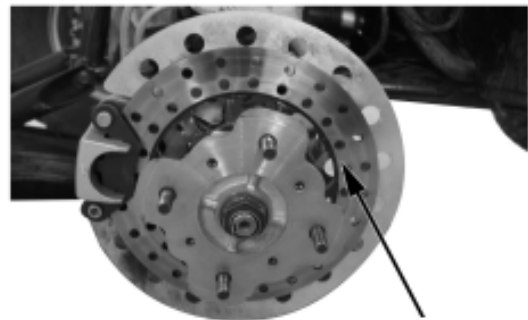

Brake Fluid Replacement

<Brake Fluid Replacement>

Replace brake fluid every year.

MASTER CYLINDER ASSEMBLY,4-WHEEL BRAKE

<Brake Fluid Level>

Check brake fluid level.

If brake fluid level is below the mark no.2,inspect master cylinder,brake lines and connections for leaks.

Unscrew reservoir cap no.1 to remove it.

Add DOT 3 or DOT 4 brake fluid only.Never exceed the mark "UPPER".

- When adding brake fluid,always avoid dirt or water.
- Always use specified brake fluid.
- Don't spill brake fluid on plastic or rubber parts,as it would damage them.
- Turn handlebar to left or right to keep the master cylinder level before the reservoir cap removal.

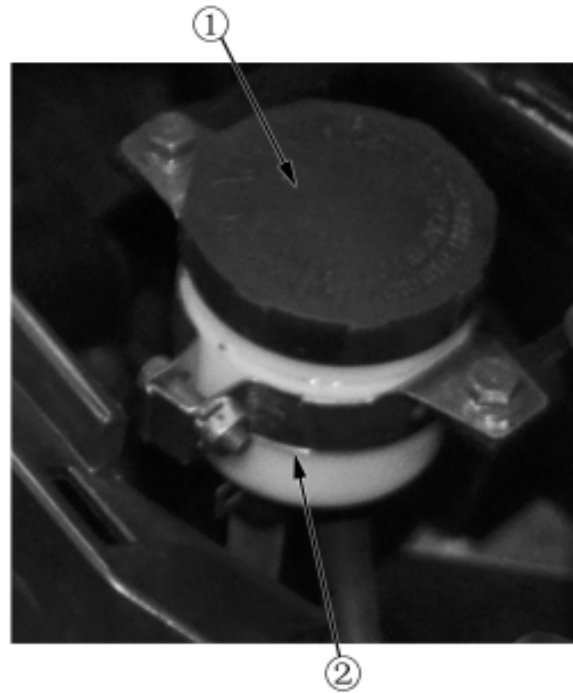

REAR BRAKE DISC& REAR BRAKE PADS

<Brake Pad Wear>

Inspect rear brake pads from the marked place.

Replace rear brake pads if they are worn to service limit groove.

CAUTION:

Pads should be replaced as an assembly.

Brake Disc Inspection&Replacement

Inspect brake disc for excessive wear or damage.Replace brake disc when its thickness is less than 2.5mm.

Front brake disc service limit thickness:2.5mm

Brake Fluid Replacement

<Brake Fluid Replacement>

Replace brake fluid every year.



WHEEL

Position the vehicle on level ground. Elevate the appropriate side of the vehicle by placing a suitable stand or other tool under the footrest frame. Shake the wheel to check for free play or looseness. If any free play or looseness is found, inspect A-arms, axle, rim bolts and nuts and tighten them if necessary.

If free play or looseness still remains, inspect bearing, A-arm bushings and ball joint pin and replace if needed.

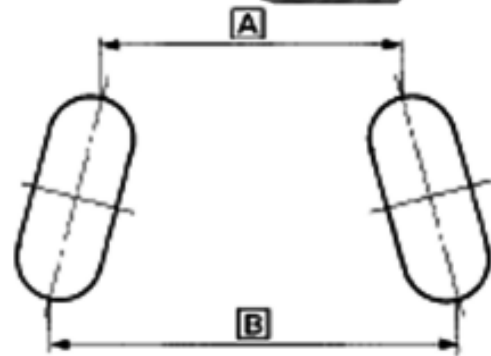

FRONT Wheel TOE-IN

Position the vehicle on level ground to measure the front wheel toe-in.

Toe-in: $B - A = 0 - 10\text{mm}$

If the measurement is out of specification, adjust the tie rod (no. 1) locking nuts no. 2.

CAUTION:

Drive the vehicle slowly after the adjustment is completed. Ensure that handlebar works properly.

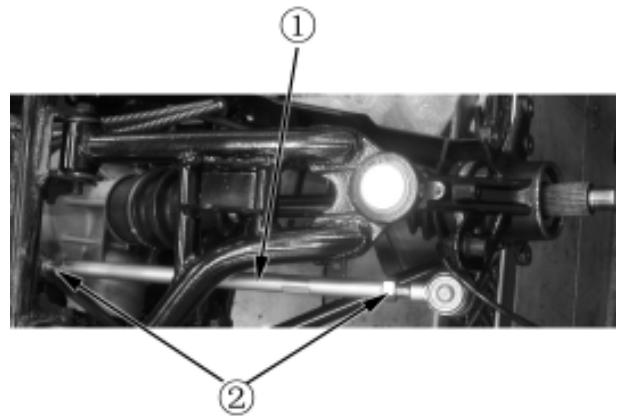

TIRE PRESSURE

Use tire pressure gauge to measure tire pressure.

CAUTION:

Test tire pressure when the tire is cold.

Maintain proper tire pressure. Improper inflation may affect ATV maneuverability, comfort, or uneven wear to different tires.

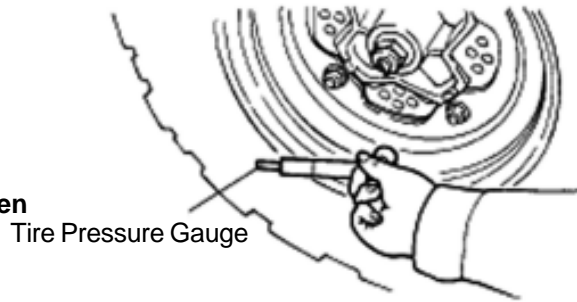

Specified Tire Pressure/Tire

	Front	Rear
Pressure	45kPa(0.45kgf/cm ²)	45kPa(0.45kgf/cm ²)
Size	See chapter 1	See chapter 1

TIRE TREAD DEPTH

Replace tires when tire depth is worn to 1/8"(3mm) or less.

CAUTION:

When tire depth is worn to 3mm or less, replace tires immediately.

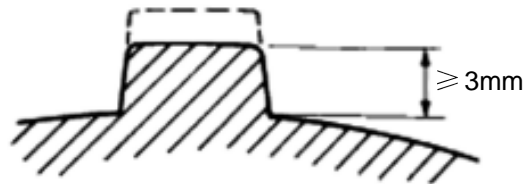

AXLE NUTS AND AXLE

Check front&rear axle nuts for looseness.

If axle nuts are loose,torque them to specified values.

Torque Specification:

Front:110-130N · m(11.2kgf · m-13.3kgf · m)

Rear:110-130N · m(11.2kgf · m-13.3kgf · m)

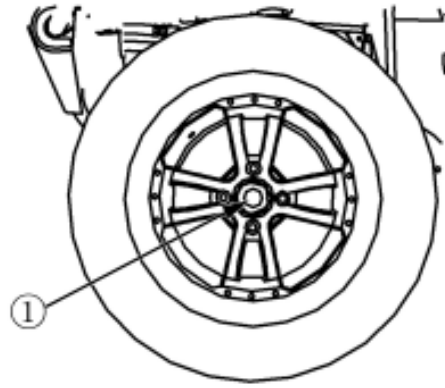

Wheel Bearing Free Play

Elevate the appropriate side of vehicle by placing a suitable stand under the footrest frame.Shake the wheel to check for free play.

If there is a free play,inspect the wheel bearing.



SUSPENSION

Position the vehicle on level ground,push and release the vehicle as illustrated.If the vehicle found unstable or abnormal sound,check shocks for leaks,damages or looseness to fasteners.

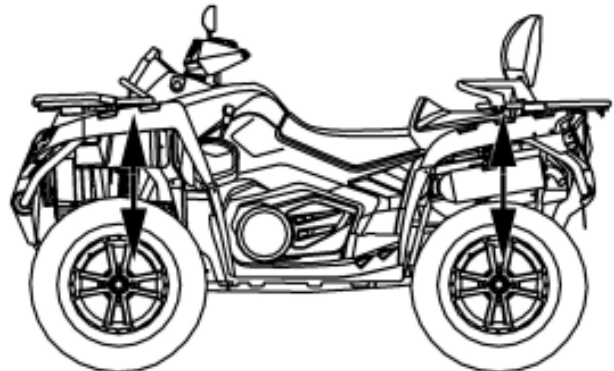

Shock Absorber Adjustment

The front and rear shock springs are adjustable. Rotate the adjuster cam no.2 clockwise to decrease the spring tension or counter-clockwise to increase the spring tension. Always adjust two sides equally.

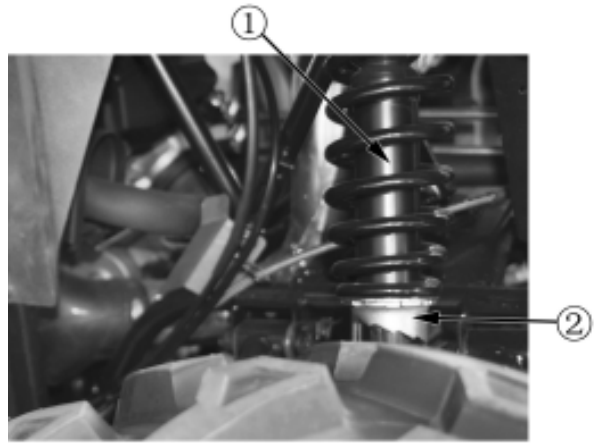

GEARSHIFT LINKAGE

Shift to check gearshift for smoothness. If not, attempt to adjust the length of gearshift rod by turning the locking nuts no.3.

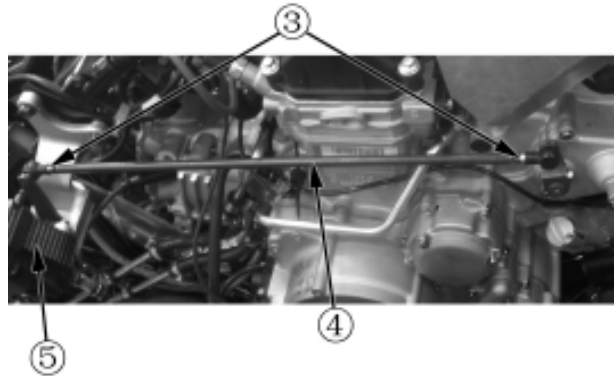

FUEL SYSTEM

Fuel System Condition

Remove seat(→2-3);

Check fuel lines for aging,damage;

Replace fuel line if aging,damage found.

Inspect fuel tank breather hose and the hose of fuel evaporation control system(if applicable) for damages, bending. Replace the hoses if any damage found.

Throttle Lever no.1 Inspection

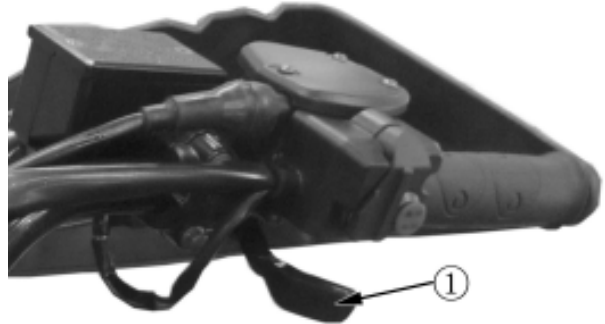

Inspect throttle lever no.1 for free play.

Free Play:3 — 5mm

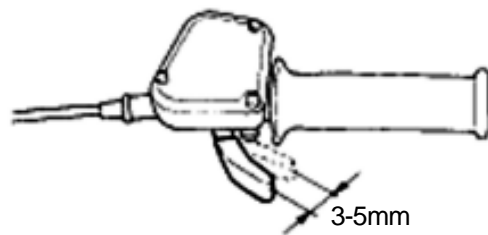

Adjust throttle lever if free play is out of specification,

Slide sleeve no.3 out of place.loosen throttle cable locking nut no.2.Turn adjuster to change the throttle lever free play.

Reinstall locking nut no.2 and throttle cable sleeve no.3.

If adjuster fails to change throttle lever free play to specified value,replace throttle cable.

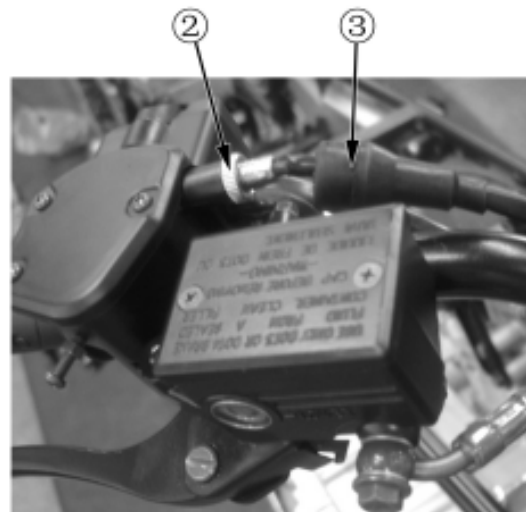

Speed Limiter

Speed limiter is designed to adjust throttle lever travel, so as to limit the max speed.

Inspect the max length of limiter screw threads

Max limiter screw threads:a=12mm

Adjustment

Loose the locking nut.

Use a cross screw driver to turn the limiter screw clockwise or counter-clockwise to adjust throttle lever travel.

CAUTION:For beginners,keep the adjuster screw clockwise turned to the max. For experienced riders,turn the adjuster screw counter-clockwise to change the throttle lever travel according to speed requirements.



COOLING SYSTEM

CAUTION:

- For safety, check the coolant level in the reservoir tank, not radiator. Never open the pressure cap when the engine is hot (more than 100°C). Escaping steam can cause severe burns. The engine must be cool before removing pressure cap.
- Coolant is toxic. Don't drink nor spill on skin, eyes, clothing.
 - If you spill coolant on your skin or clothing, immediately wash it off with soap.
 - If you get coolant in your eyes, immediately wash it off before medical attention.
 - If you swallow coolant, immediately spit it out and gargle before medical attention.
- Coolant must be kept out of reach of children.

Coolant Level

Coolant would decrease due to evaporation, etc. Inspect coolant level periodically.

CAUTION:

- Coolant is anti-rust and anti-freezing. Using tap water will rust the engine, and may crack the engine when it's freezing. Always use specified coolant.
- Position the vehicle on level ground before cooling system inspection.
- Start the engine and warm it up before inspecting the cooling system.

Start the engine and warm it up.

Shut off the engine.

Inspect the coolant level, ensure that the level is between "LOWER" and "UPPER".

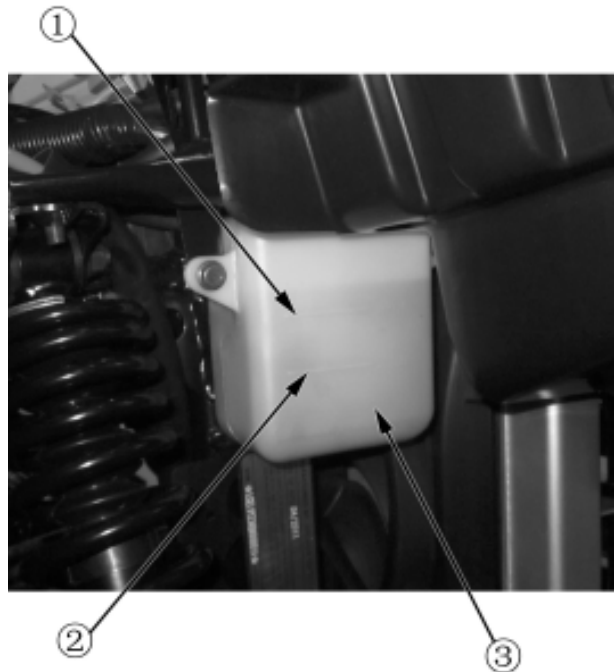

When the coolant level is below the mark no.1-"LOWER",remove the reservoir tank cap and add coolant to the mark no.2-"UPPER".

Recommended Coolant:CFMOTO coolant.

Standard Mixture Ratio:50%(The freezing temperature varies according to the mixture ratio.

Adjust the mixture ratio according to freeze protection required in your area.)

When coolant is reduced significantly,inspect the cooling system for leaks.If no coolant remains in the reservoir tank no.3,there may be air in the cooling system.Purge the cooling system of air.

Coolant Leakage

Inspect radiator hoses,water pump,and connections for leaks.

If any leaks found,repair the cooling system.(→ **Chapter 4)**

Inspect radiator hoses for aging,damages and cracks. Hoses ages over time due to special working conditions and may crack.Bend a hose to inspect for cracks. If any damages or cracks found,replace it with a new hose.

Inspect coolant hose clamps and tighten the loose ones.

Inspect radiator fins for damages or mud.

Correct the fin bending.Use tap water or compressed air to clean off the mud.

The radiator should be replaced when 20% fins are damaged.

4.Coolant Radiator 5.Oil Radiator

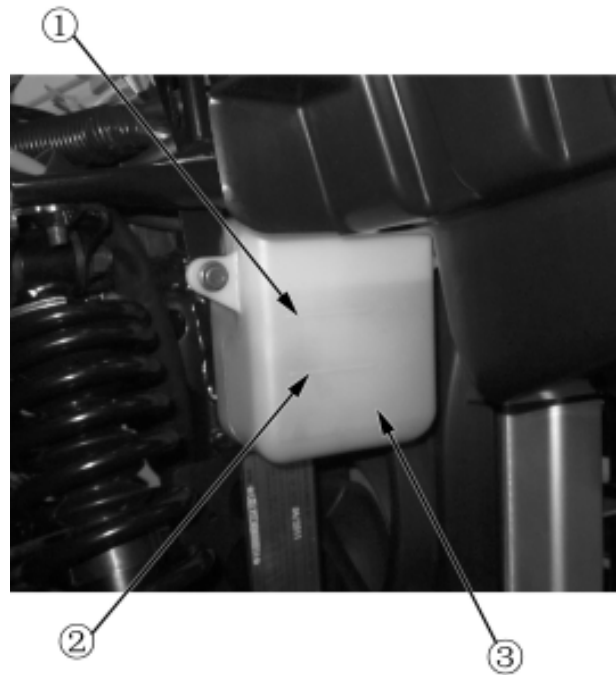

Coolant Gauge Inspection

The indicator should point at 0 when the engine is not working. Start the engine to check coolant gauge for response. If the indicator doesn't move, determine the cause and take a repair.

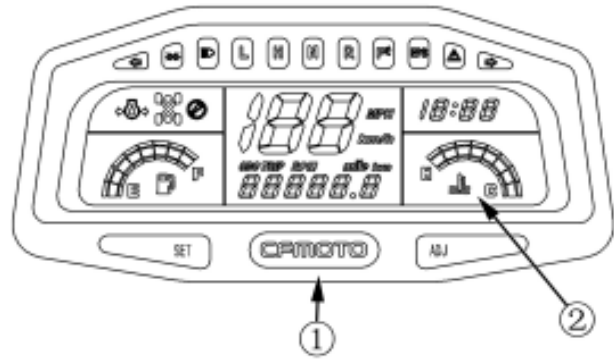

LIGHTING

Headlight Beam Adjustment

Remove headlight protector(→2-11)

In order to adjust headlight beam, adjust bolt no.4 with a cross screw driver or adjust nut no.3. with a wrench.

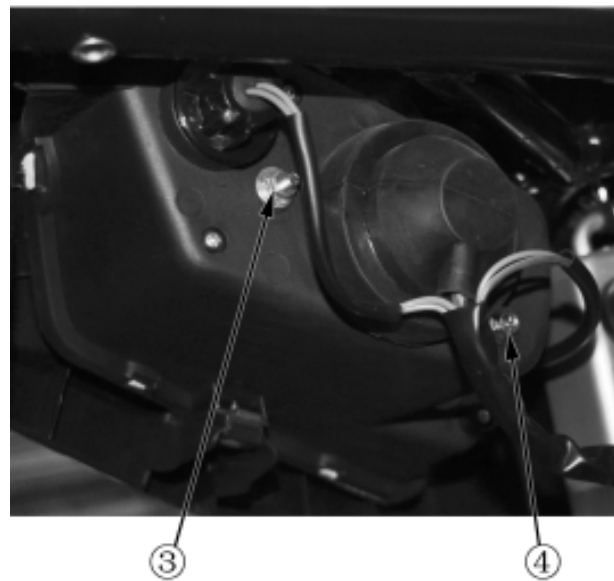

COOLING SYSTEM**SERVICE TOOLS**

Description	P/N	Page
Test Cap	9010-180100-922-001	04
Special Puller	0800-014001-922-002	15
Bearing Puller	0800-014001-922-001	15
Press Tool,Oil seal	0110-080005-923-001	16
Press Tool,Bearing	0800-014001-921-003	17

SERVICE PRODUCTS

Description	P/N	Page
Retaining Compound		03
Coolant		05
Engine Oil		16
Loctite 5699		17

WATER PUMP

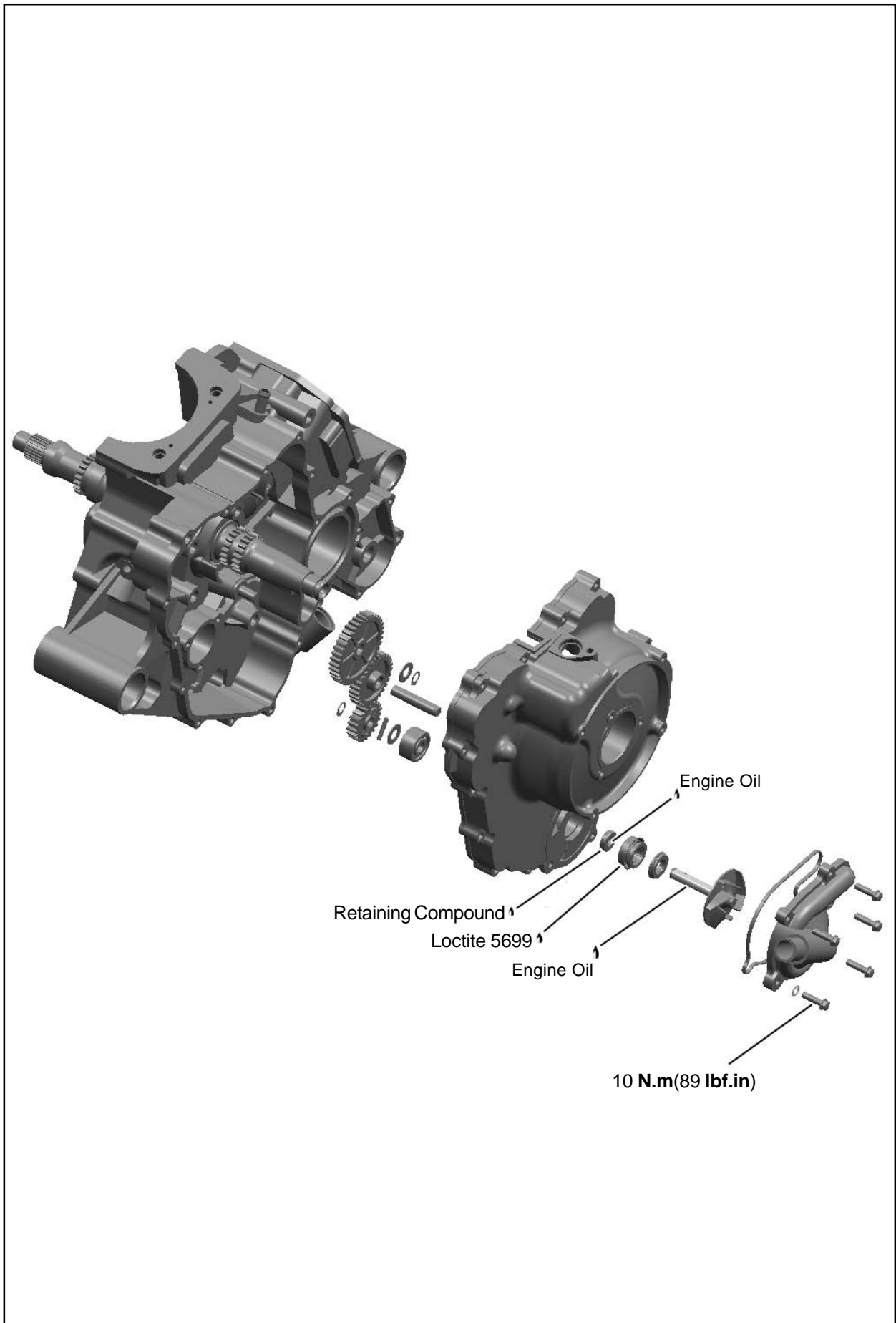

GENERAL

WARNING

Never start engine without coolant. Some engine parts such as the rotary seal on water pump shaft can be damaged.

During installation, use the torque values and service products as in the exploded views. Clean threads before applying a threadlocker. Refer to **LUBRICANTS AND SERVICE PRODUCTS** at the beginning of this manual for complete procedure.

WARNING

Torque wrench tightening specifications must strictly be adhered to. Locking devices (e.g.: locking tabs, elastic stop nuts, self-locking fasteners, etc.) must be installed or replaced with new ones where specified. If the efficiency of a locking device is impaired, it must be replaced.

INSPECTION

COOLING SYSTEM LEAK TEST

WARNING

To avoid potential burns, don't remove the radiator cap or loosen the cooling drain plug if the engine is hot.

Remove battery cover to access and remove radiator cap.

Install the test cap (P/N 901-18.01.00-922-001) on the filler neck.

Use a pressure/vacuum pump to pressurize system to 103kpa (15PSI).

Check all hoses, radiator and cylinder(s)/base for coolant leaks or air bubbles.

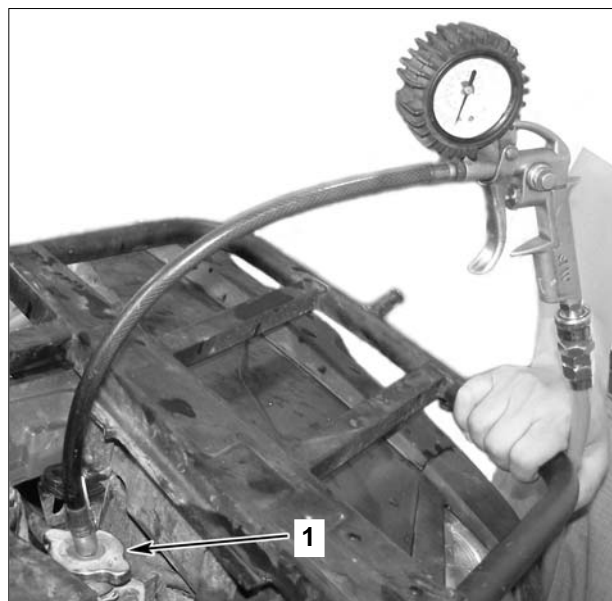

1. Special Radiator Cap.

Inspection

Check general condition of hoses and clamps tightness.

Check the leak indicator hole if there is oil or coolant.

NOTE: *Leaking coolant indicates a defective rotary seal. Leaking oil indicates a defective inner oil seal. If either seal is leaking, both seals must be replaced at the same time. Refer to **WATER PUMP SHAFT AND SEALS** in this section.*

Another leak indicator hole is visible on the PTO side. It indicates if the PTO gasket is in good condition. If a liquid leaks by this hole, the PTO gasket replacement is necessary.

MAINTENANCE

COOLANT REPLACEMENT

WARNING

To avoid potential burns, don't remove the radiator cap or loosen the cooling drain plug if the engine is hot.

Use CFMOTO premixed coolant or a blend of 50% antifreeze with 50% water.

To avoid antifreeze deterioration, always use the same brand. Never mix different brands unless cooling system is completely flushed and refilled.

CAUTION: To prevent rust formation or freezing condition, always fill the system with the CFMOTO premixed coolant or with 50% antifreeze and 50% water. Don't use tap water, straight antifreeze or straight water in the system. Tap water contains minerals and impurities which build up in the system. During cold weather, straight water causes the system to freeze while straight antifreeze thickens and does not have the same efficiency. Always use ethylene glycol antifreeze containing corrosion inhibitors specifically recommended for aluminum engines.

Draining the System

WARNING

Never drain or refill cooling system when engine is hot.

Remove the radiator cap.

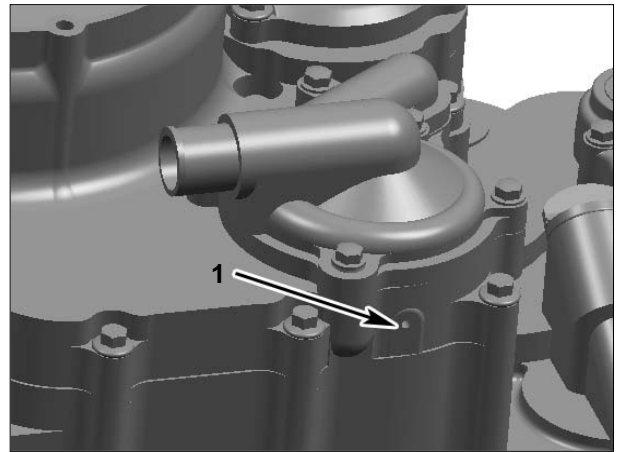

1. leak Indicator Hole

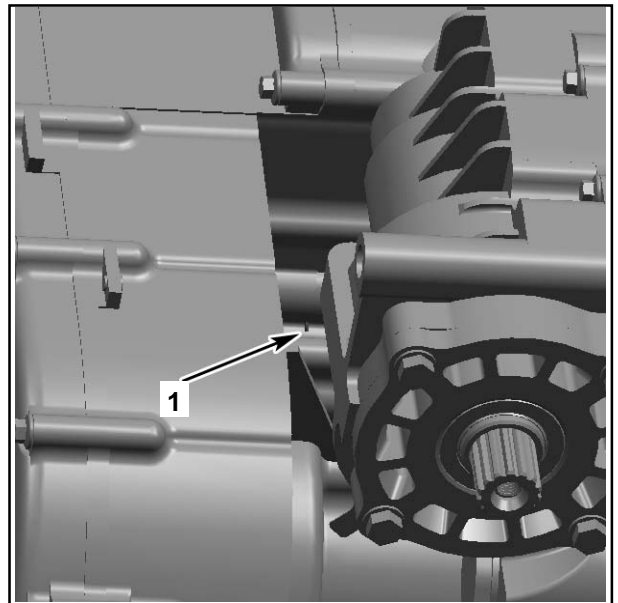

1. leak Indicator Hole

Partially unscrew cooling drain plug located below water pump housing.

When cooling system is drained completely, remove cooling drain plug completely and install a new washer. Screw the cooling drain plug and torque it to 10N.m (89lbf.in)

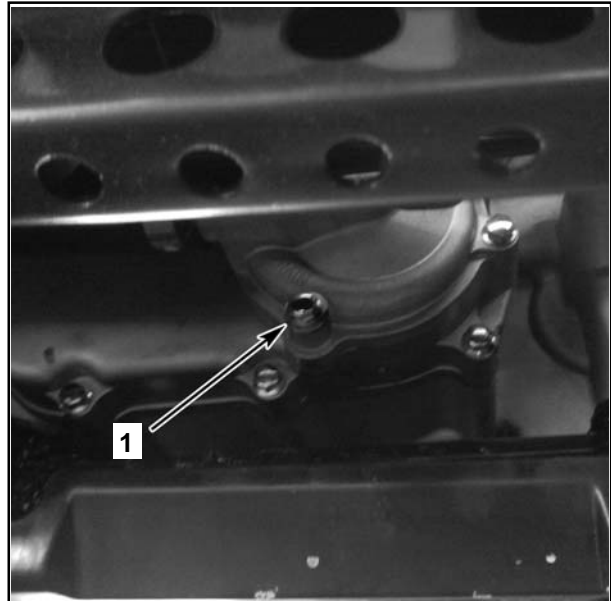

Under LH Footrest
1. Cooling Drain Plug

Refilling the System

Remove related parts.

Unscrew bleeding screws on top of thermostat housing.

NOTE: Both two cylinders must be bled.

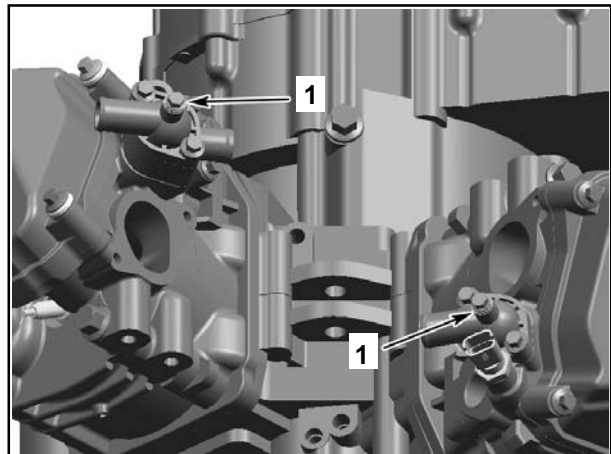

1. Bleeding Screws

With vehicle on a flat surface, engine cold, refill radiator. When the coolant comes out by the thermostat housing hole, install the bleeding screw with its washer and torque to 5 **N.m**(44 **lbf.in**).

Fill up the radiator and install radiator cap.
 Fill the reservoir tank and keep the coolant level even at "LOWER" mark, then install reservoir tank cap.
 Run the engine until thermostat opens, then shut off the engine.
 Recheck the coolant level in reservoir tank after the engine is completely cooled down. Refill coolant if necessary. Maintain coolant level between "LOWER" and "UPPER".

NOTE: Each year or every 100 hours or when vehicle reaches 3000km(1865mi), check coolant concentration (freezing point) with proper tester.

PROCEDURES

THERMOSTAT

The thermostat is a single action type.

Thermostat Removal

NOTE: Thermostat is located on the top of cylinder head, on intake side (front cylinder).

Install a hoe pincher on both radiator hoses.

Remove:

— thermostat housing screws and pull thermostat cover.

— thermostat with seal ring out of the hole.

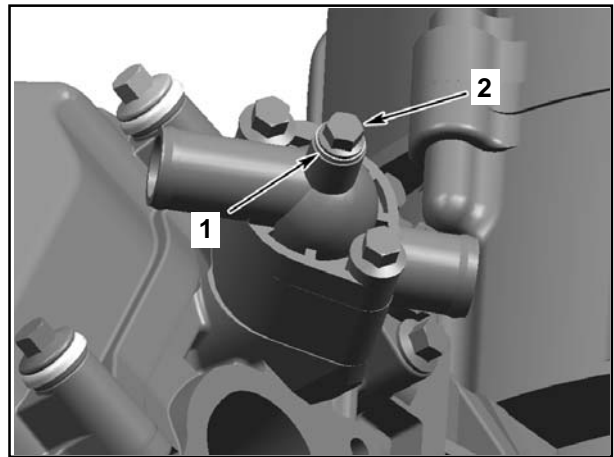

1. Washer
 2. Bleeding Screw

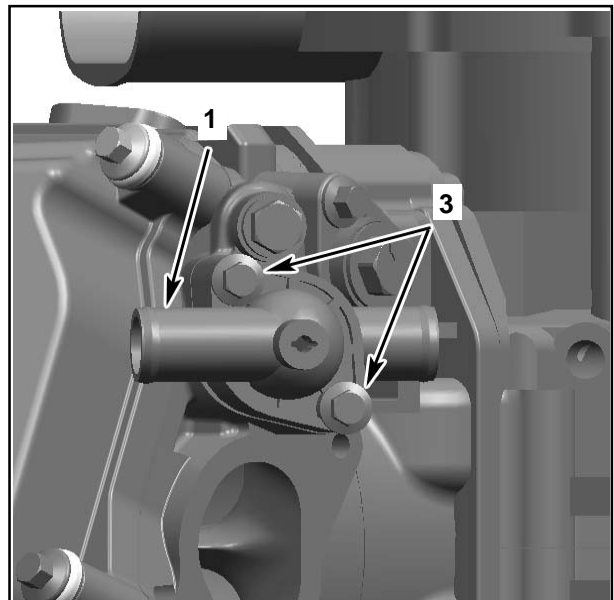

1. Thermostat Cover
 2. Screws

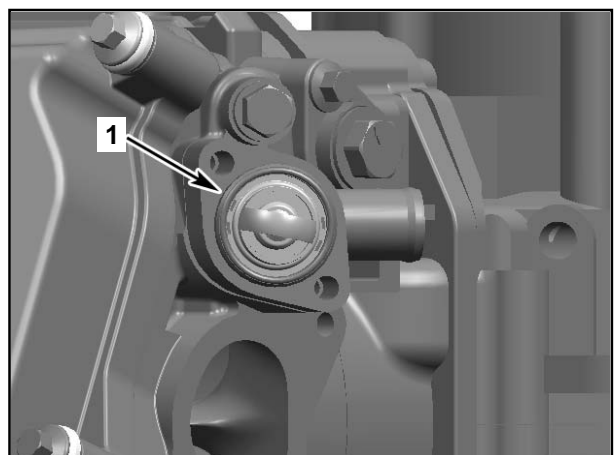

1. Thermostat with Seal Ring

Thermostat Test

To check thermostat, put it in water and heat water. Thermostat should open when water temperature reaches 65°C (149°F).

Check if the seal ring is brittle, hard or damaged. If so, replace the seal ring.

Thermostat Installation

For installation, reverse the removal procedure, pay attention to the following details.

Install the thermostat cover then torque screws to **6N.m** (53lbf.in).

Check coolant level in radiator and reservoir tank and top up if necessary.

CAUTION:

Don't forget to bleed the cooling system. Refer to **COOLANT REPLACEMENT**.

RADIATOR CAP

Using a pressure cap tester, check the efficiency of radiator cap. If the efficiency is feeble, install a new 110kPa (16PSI) cap (don't exceed this pressure).

RADIATOR

Radiator Inspection

Check radiator fins for clogging or damage. Remove insects, mud or other obstructions with compressed air or low pressure water.

Radiator Removal

Drain cooling system

Remove front fascia and radiator shroud, refer to **VEHICLE BODY AND MUFFLER**.

Remove:

- RH inner fender
- radiator mounting bolts
- overflow hose
- support and reservoir tank

Unplug radiator fan.

Remove radiator.

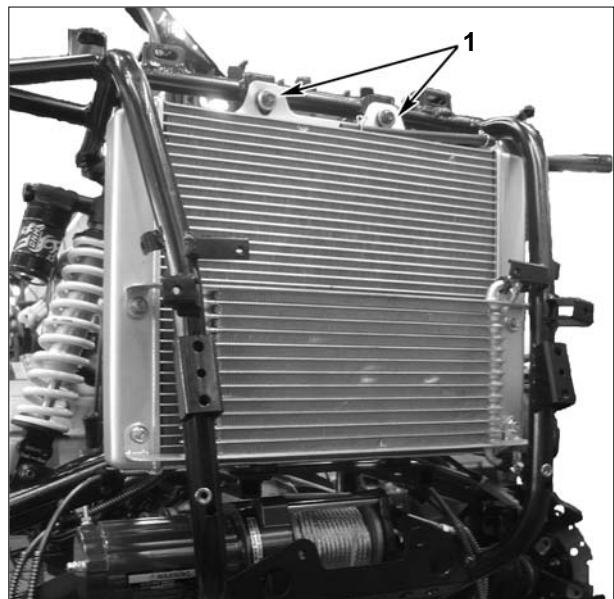

1. Radiator Mounting Bolts

Radiator Installation

Reverse the removal procedure for installation. Pay attention to the following details.

RESERVOIR TANK

The coolant expands as the temperature (up to 100 to 110 °C (212 to 230 °F)) and pressure rise in the system. If the limiting system working pressure cap is reached 110kPa (16PSI), the pressure relief valve in the temperature cap is lifted from its seat and allows coolant to flow through the overflow hose into the reservoir tank. Ensure ventilation holes are not obstructed.

Removal

Remove:

—— RH inner fender (refer to **VEHICLE BODY AND MUFFLER**).

—— coolant support bolt

—— overflow hose

—— support and reservoir tank

Empty coolant tank.

Installation

Reverse the removal procedure for installation.

COOLANT TEMPERATURE SENSOR (CTS)

Refer to **ELECTRICAL SYSTEM** for inspection and renewal process of CTS.

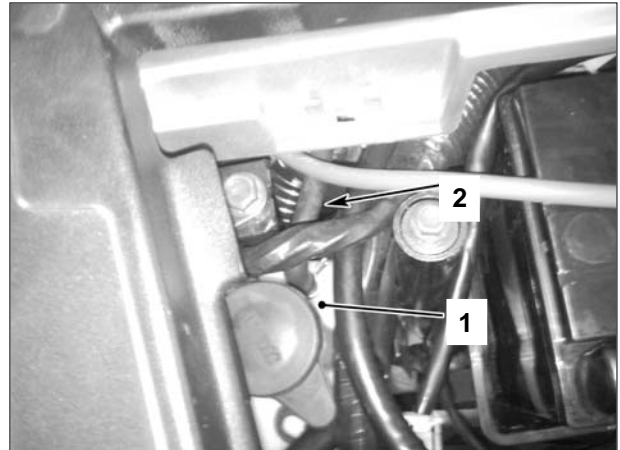

1. Reservoir Tank
2. Overflow Hose

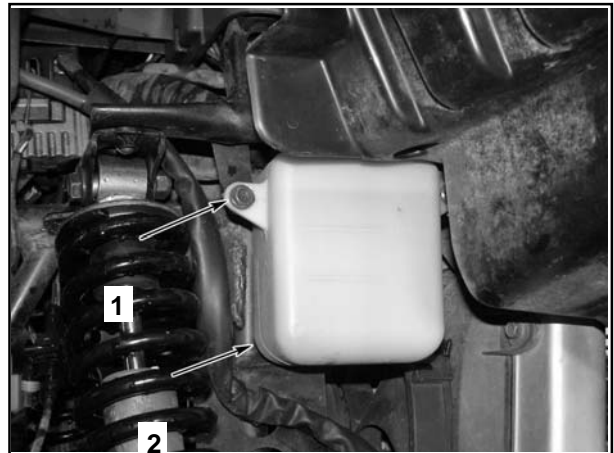

1. Bolt
2. Reservoir Tank

RADIATOR FAN RELAY

Installation

NOTE: Relay may be inverted by 180° at installation and it will work correctly. Ensure to align tabs of relay with terminals of fuse holder at installation.

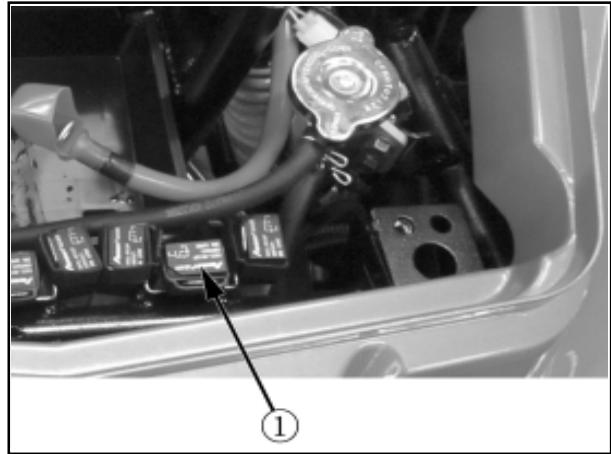

1. Radiator Fan Relay

Relay Operation Test

The easiest way to check the relay is to remove it and bypass it with a jumper. If the radiator fan is activated, replace the relay. See illustration to find where to bypass the relay.

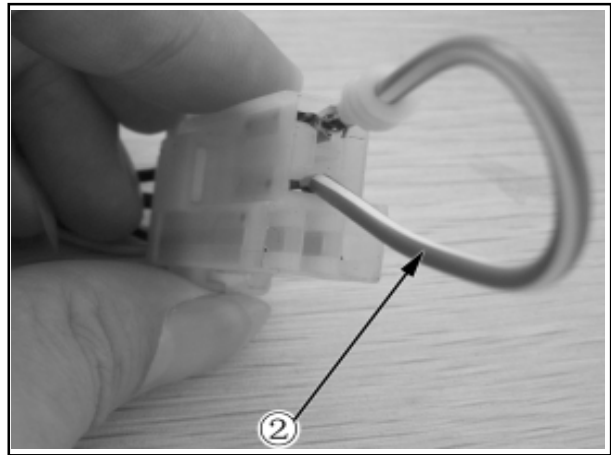

2. Bypass the Relay

Relay Continuity Test

Remove relay.
Use multimeter and select the Ω position.
Probe relay as follows.

Terminals		Resistance
30	87	Open circuit (OL)



3. Probe Relay

Connect battery as follows.

Terminals		Resistance
30	87	0.5 Ω max. (continuous)

If relay fails any test, replace it.

RADIATOR FAN

Operation

The thermal switch controls the radiator operation. Radiator fan should turn on when coolant temperature reaches 88°C (190.4°F) and should turn off when the coolant cools down at 84°C (183.2°F).

Radiator Fan Test

If radiator fan doesn't turn on when the coolant temperature exceeds 88°C (190.4°F), use the following troubleshooting chart to resolve the problem.

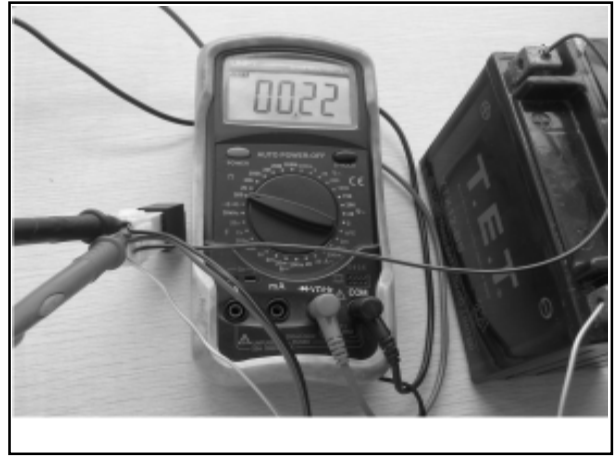

4. Connect Battery

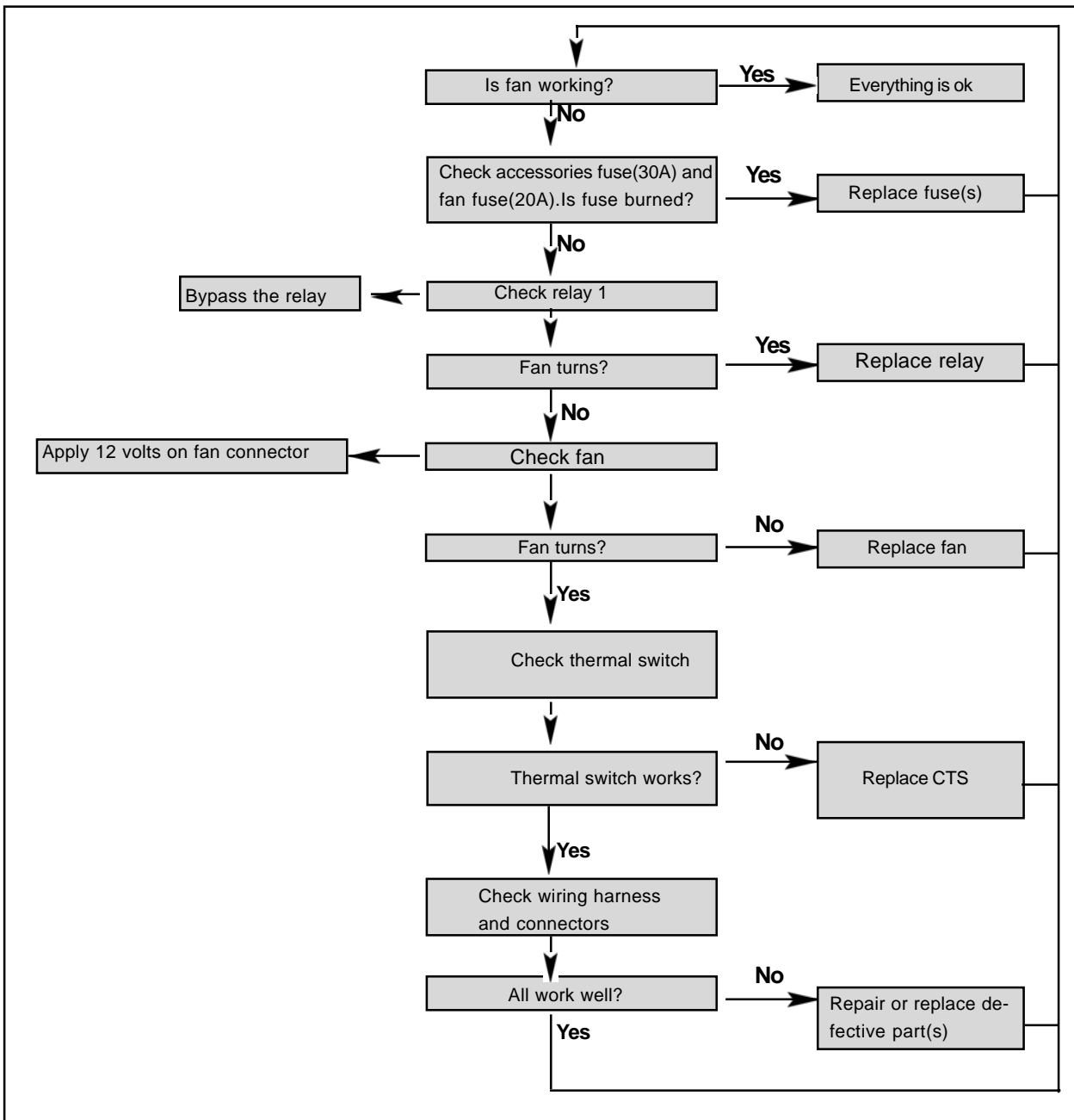

Removal

- Remove radiator shroud.
- Remove the bolts.
- Remove the radiator fan.

Installation

Reverse the removal procedure for installation.

WATER PUMP HOUSING

It's located on the engine MAG side.

Removal

WARNING

To avoid potential burns, don't remove the radiator cap or loosen the cooling drain plug if the engine is hot.

Drain the cooling system.

Remove outlet hose from water pump housing.

Remove screws retaining water pump housing.

Pull water pump to remove it.

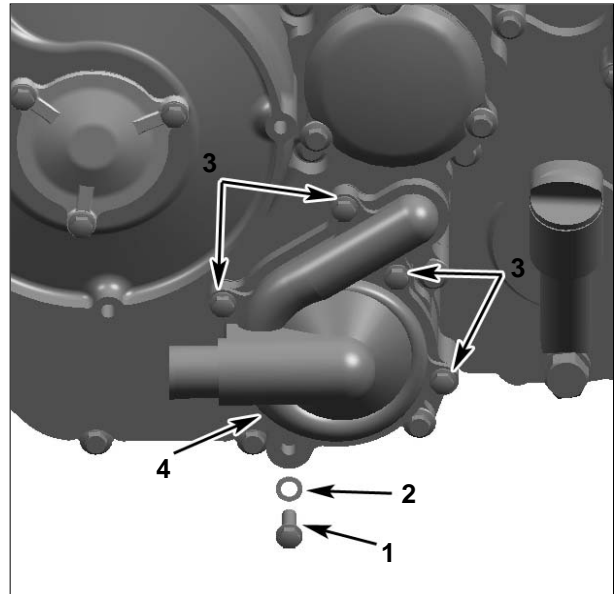

1. Cooling Drain Plug
2. Sealing ring
3. Screws
4. Water Pump Housing

Inspection

Check if gasket is brittle, hard or damaged and replace as necessary.

Installation

Reverse the removal procedure for installation.

CAUTION: To prevent leaking, take care that the gasket is exactly in groove when you reinstall the water pump housing.

Tighten screws of water pump housing in a criss cross sequence.

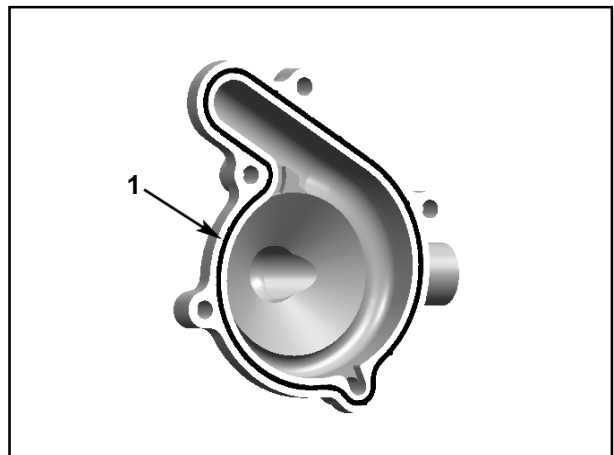

1. Gasket

WATER PUMP IMPELLER, GEARS, SEALS, SHAFT

Removal

Drain cooling system. Refer to this chapter.

Empty engine oil. Refer to **LUBRICATION SYSTEM**.

Remove water pump housing. Refer to this chapter.

Remove the crankcase cover, MAG side. Refer to crankcase.

Remove the water pump intermediate gear and breather shaft.

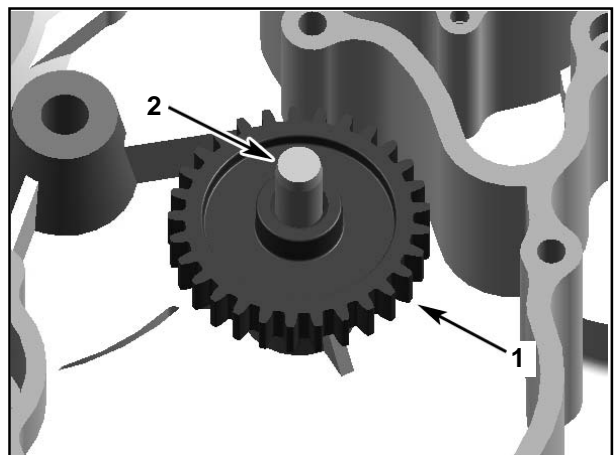

1. Intermediate Gear, Water Pump
2. Breather Shaft

Using appropriate pliers,remove and discard the retaining ring securing water pump gear on water pump shaft.

Remove water pump gear.

Remove needle pin and gasket of water pump shaft.

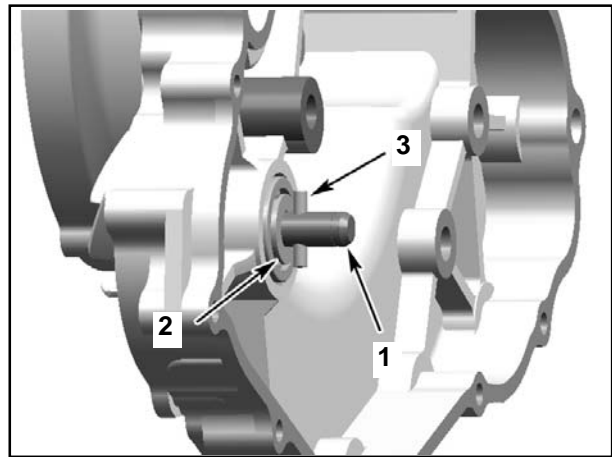

1. Water Pump Impeller Assembly

2. Gasket

3. Needle Pin

To remove water pump impeller assembly from left crankcase cover, briskly tap the water pump shaft end.

CAUTION:Take care not to damage impeller wings during installation.

Using an appropriate slotted screwdriver,pry out the rotary seal.

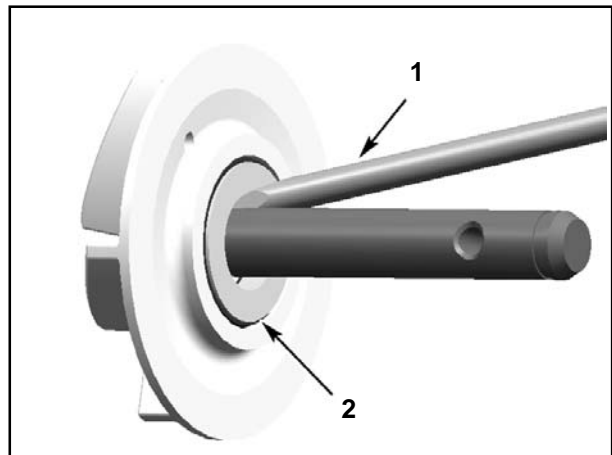

1. Slotted Screwdriver

2. Rotary Seal

Using 2 slotted screwdrivers ,remove outer part of water pump stationary seal.

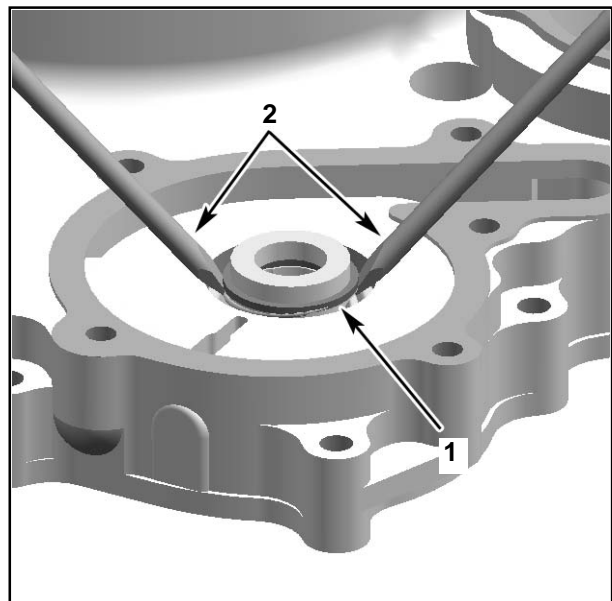

1. Stationary Seal, Water Pump

2. Slotted Screwdrivers

Using a puller,remove outer part of rotary seal.
Install puller snugly against outer part and pull rotary seal out.

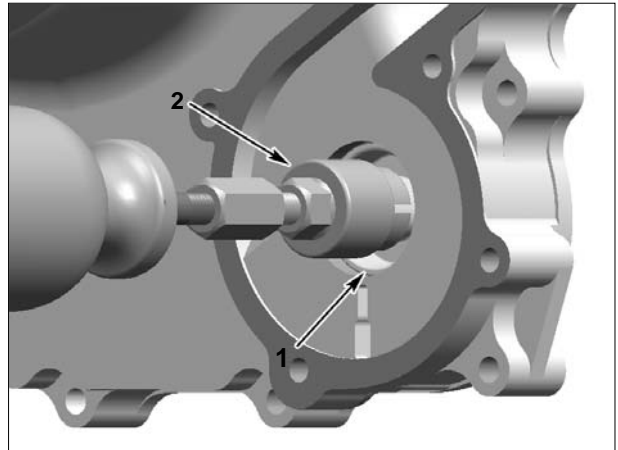

1.Inner Part,Stationary Seal

2.Seal Puller

Using a bearing puller(P/N:0800-014001-922-001),re-
move water pump bearing(If it's necessary to replace
the water pump bearing).

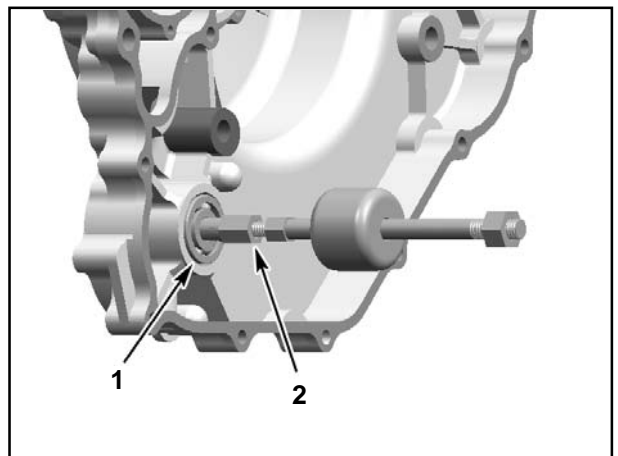

1.Bearing

2.Bearing Puller

Remove oil seal.

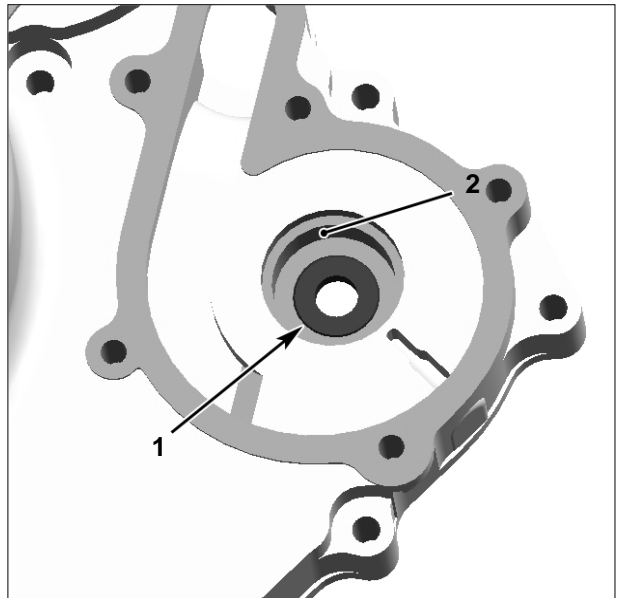

1.Oil seal

2.Stationary Seal Surface

CAUTION:

Be careful not to damage the rotary seal surface.

Inspection

Check impeller for cracks or other damages. Replace impeller if damaged.

Inspect water pump intermediate gear and water pump gear for cracks, wear and other damages (especially on the snap mechanism to the needle pin). Replace if necessary.

Turn the bearing inner ring by hand. The bearing should run smoothly, peacefully. If it's stuck or has noise or other defects, replace it.

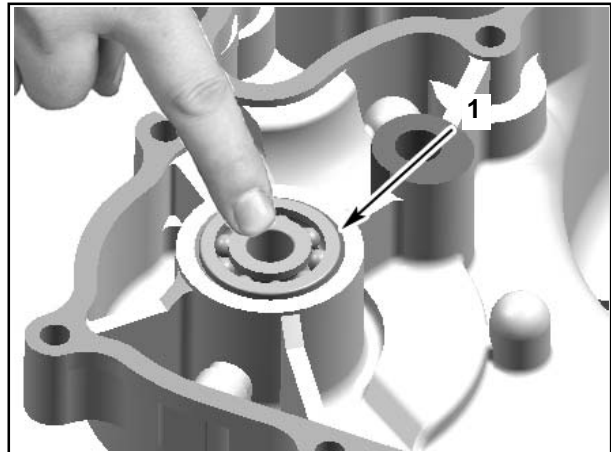

1. Bearing

Installation

For installation, reverse the removal procedure. However, pay attention to the following.

NOTE: For installation, use the torque values in the exploded view. Ensure to apply engine oil on intermediate shaft, water pump shaft and oil seal inner surface. Don't use oil in the press fit area of the oil seal and rotary seal.

CAUTION: Always replace rotary seal and stationary seal at the same time. Meanwhile, install a new oil seal (behind the rotary seal).

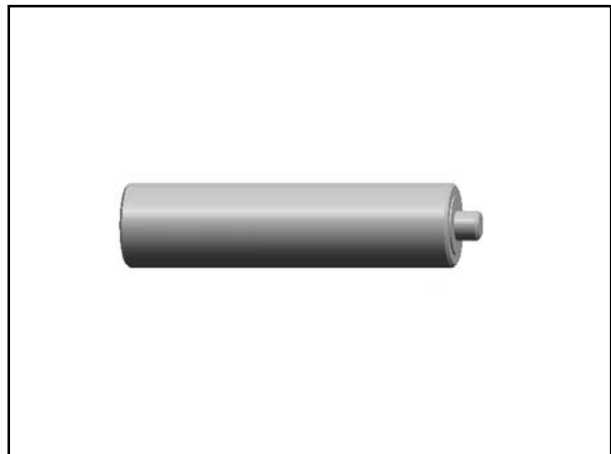

Seal Pusher

Use the oil seal pusher (P/N 0110-080005-923-001) to install oil seal.

Apply oil on oil seal lip.

When installing the oil seal on the pusher, make sure sealing lip points outside.

Using oil seal pusher, install the oil seal in place.

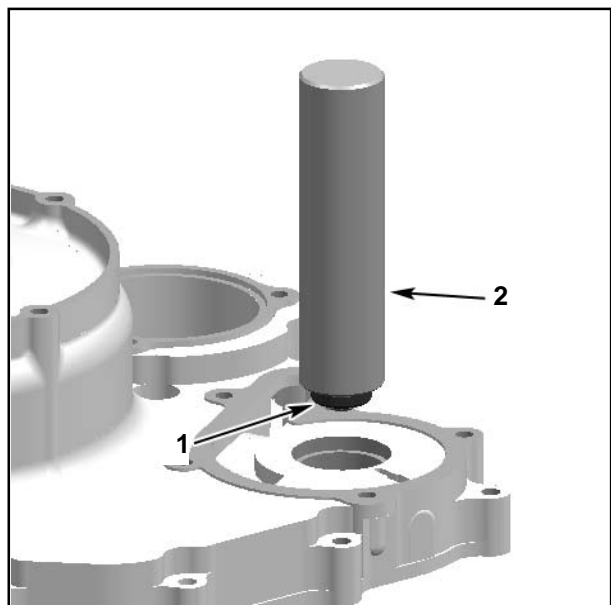

1. Oil seal

2. Seal Pusher

Place appropriate cushion blocks under the crankcase cover to keep it level.
Using bearing pusher to push the bearing into left crankcase press fit area.

NOTE: *The left crankcase cover may be damaged if no appropriate cushion bolks placed under it.*

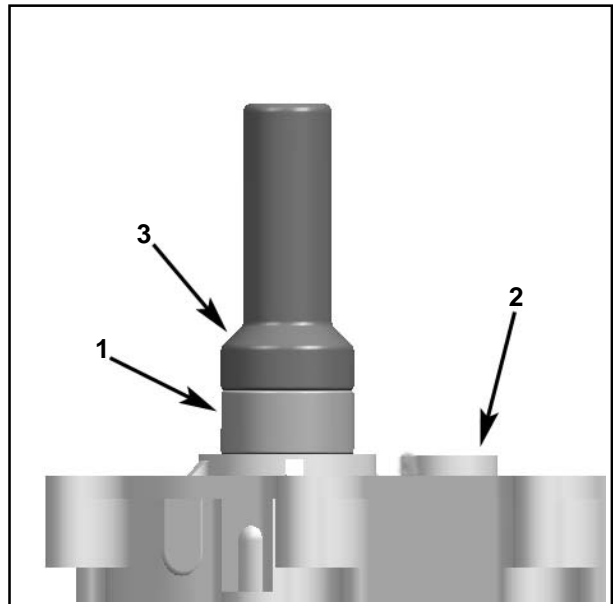

1. Bearing
2. Crankcase Cover, MAG Side
3. Bearing Pusher

Apply loctite (silicone sealant) on stationary seal surface.
Gently tap the seal pusher to install stationary seal in place.

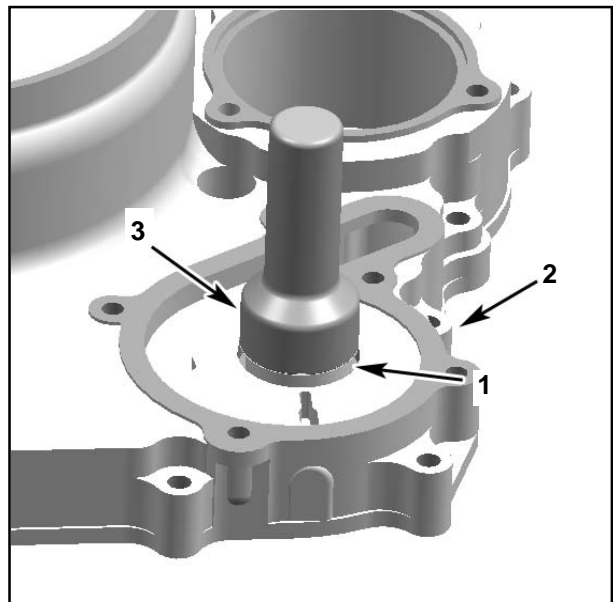

1. Stationary Seal, Water Pump
2. Crankcase Cover, MAG Side
3. Seal Pusher

Install the water pump impeller assembly with rotary seal into left crankcase cover.

NOTE: Before water pump impeller installation, clean the rotary seal and stationary seal surface, or water may enter the crankcase.

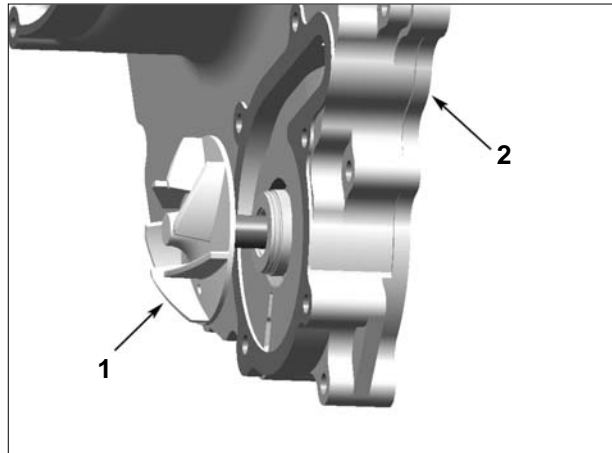

1. Water pump Impeller Assembly
2. Left(MAG Side) Crankcase Cover

Install thrust washer on water pump shaft.

Push impeller by hand to fully expose shaft hole that needle pin can be installed.

Install pin and position it at equal distance out of shaft hole so water pump gear can be installed.

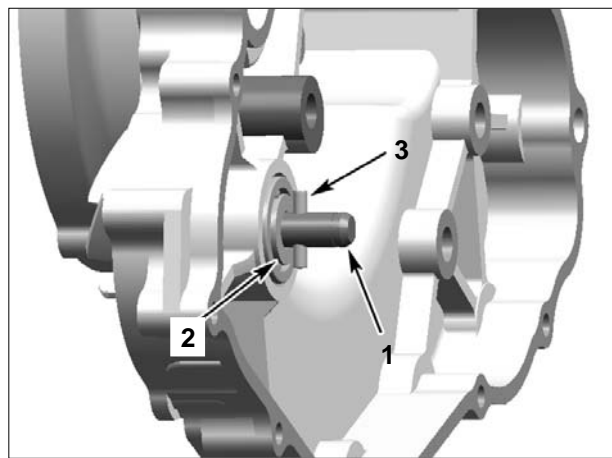

1. Water Pump Impeller Assembly
2. Gasket
3. Needle Pin

Align the water pump gear groove with needle pin, then install water pump gear on the shaft.

Make sure gear properly snaps on pin.

Install a new retaining ring on pump shaft end.

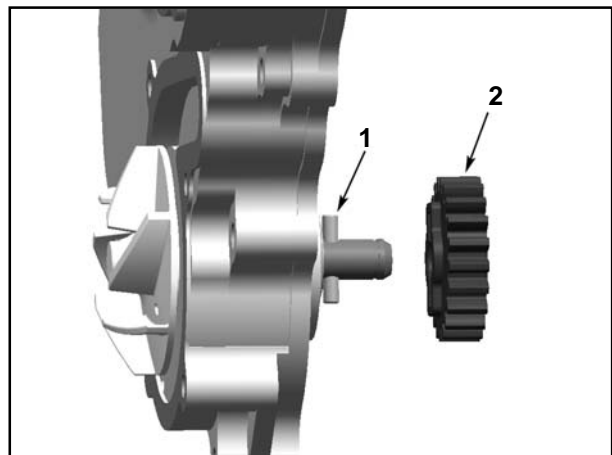

1. Needle Pin
2. Water Pump Gear

Install water pump intermediate shaft and ensure its end with chamfer points outside.

Install water pump intermediate gear on shaft.

For remaining parts installation, reverse their removal procedure.

Assemble the other parts base on reverse sequence of removal.

Refill all fluids, including coolant and engine oil.

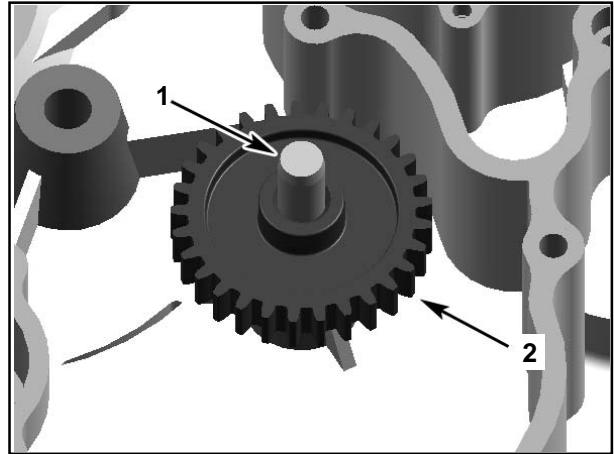

1. Breather Shaft

2. Intermediate Gear, Water Pump

5 ENGINE REMOVAL AND INSTALLATION

Maintenance Information	5-1	Differential and gearcase removal and installation...	5-6
Engine removal and installation	5-2	Gearshift linkage removal and installation.....	5-8

MAINTENANCE INFORMATION

Operation Cautions:

- When performing engine removal and installation, use jack or other appropriate tools to securely support the vehicle. Take care not to damage the engine, bolts and cables.
- Wrap the frame in appropriate areas where might be scratched to avoid damage during removal and installation.
- It's not necessary to remove the engine when servicing the following parts:
 - oil pump.
 - throttle body, air filter.
 - valve cover, cylinder head, cylinder, camshaft.
 - CVT system, CVT cover.
 - magneto cover, AC magneto, water pump
 - piston, piston ring, piston pin
 - front differential, rear gearcase
- It's necessary to remove engine when servicing the following parts:
 - crankshaft
 - transmission.

Tightening Torque:

Engine mounting bolts (upper)	GB5789 M8X35	(35-45)N•m
Engine mounting bracket bolts (upper)	GB5789 M10X1.5X20	(40-50)N•m
Engine mounting bolts (front left)	GB5789 M10X1.25X125	(40-50)N•m
Engine mounting bolts (front right)	GB5789 M10X1.25X100	(40-50)N•m
Engine mounting bracket bolts (rear)	GB5789 M8X20	(35-45)N•m
Engine mounting bolts (rear)	GB5789 M10X1.25X170	(40-50)N•m
Engine mounting bracket bolts (rear)	GB5789 M8X20	(35-45)N•m

ENGINE REMOVAL

Remove plastics (→ **VEHICLE BODY AND MUFFLER**,Chapter 2);

Remove air filter (→ **AIR INTAKE** system);

Remove throttle body(→ **ELECTRICAL SYSTEM**);

Drain coolant;

Drain engine oil;

Remove hose clamp no.2;

Remove coolant inlet hose no.1;

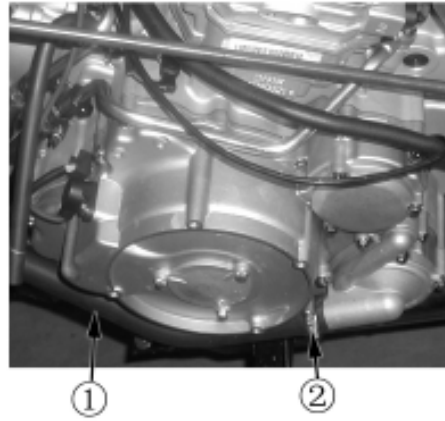

Remove hose clamp no. 4;

Remove coolant outlet hose no.3;

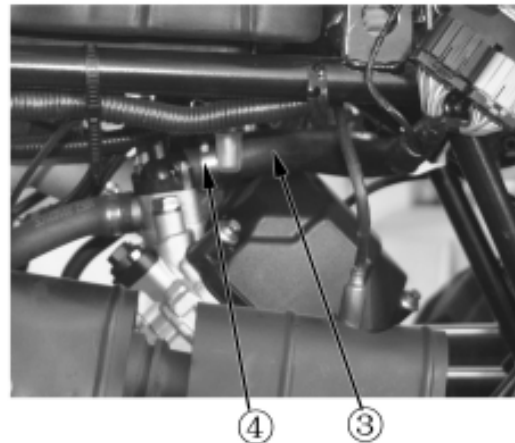

Remove hose clamp no.5;

Remove engine external oil pipe no.6;



Disconnect magneto connector,CPS connector,coolant temperature sensor connector,gear position sensor connector,TPS connector,idle air control valve connector,high pressure fuel line and throttle cable, etc;

Remove muffler(→ **VEHICLE BODY AND MUFFLER**,Chapter 2);

5 ENGINE REMOVAL AND INSTALLATION

Remove spark plug cap no.1 from cylinder 1(front);

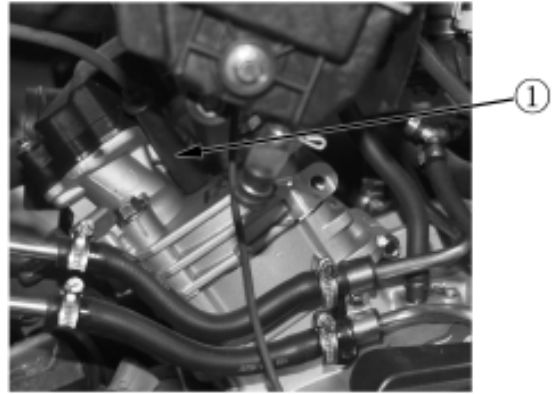

Remove spark plug cap no.2 from cylinder 2(rear);

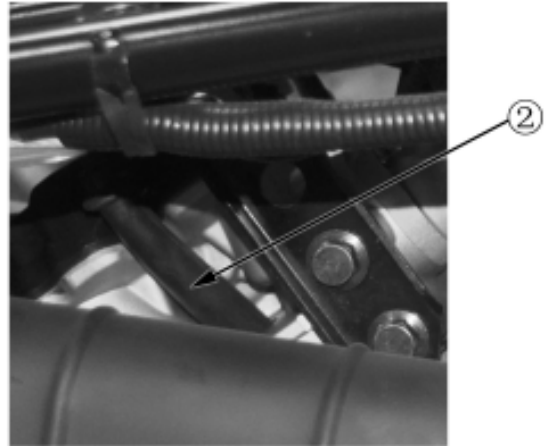

Take starter motor positive terminal sleeve off. Remove the nut and starter motor positive cable no.3;

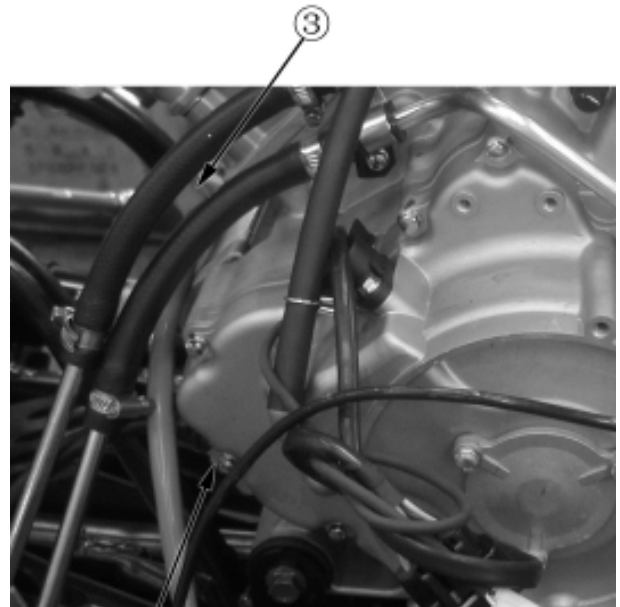

Remove the bolt and negative cable no.4 of starter motor;

④

Remove the 4 bolts no.1 to disconnect front propshaft from engine;



Remove the 4 bolts no.3 to disconnect rear propshaft from engine;

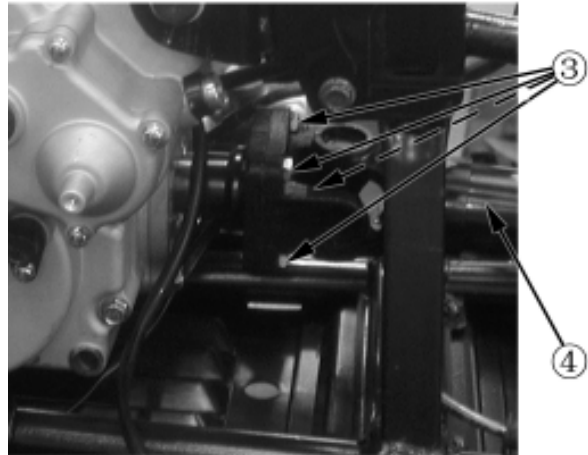

Remove CVT inlet hose clamp no.5;
Remove CVT inlet hose no.6;

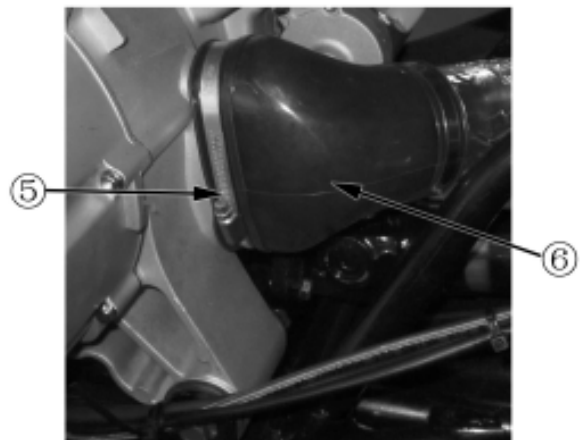

Remove CVT outlet hose clamp no.7;
Remove CVT outlet hose no.8;

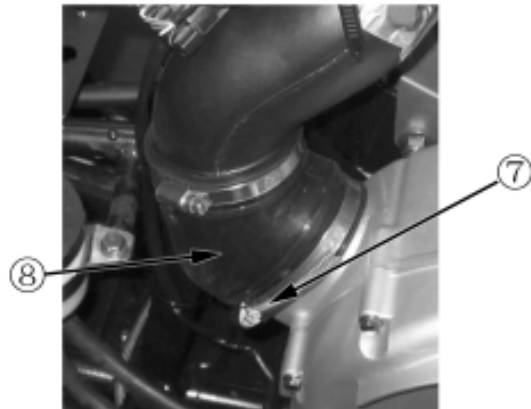

5 ENGINE REMOVAL AND INSTALLATION

Remove bolt no.1 to disconnect shifting plate no.2 from engine;

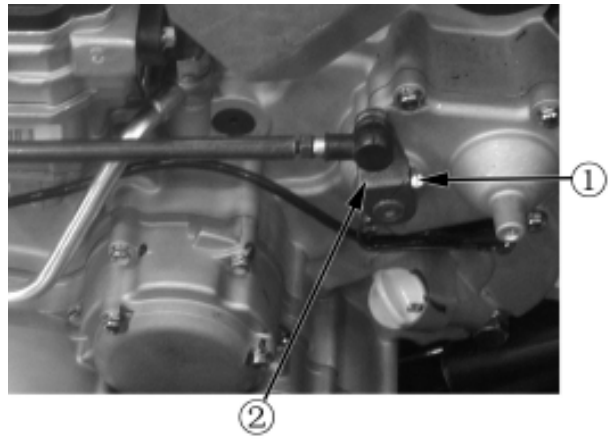

Remove engine mounting bolts (front left)&(front right) no.4;



Remove engine mounting bolts(rear) no.3;

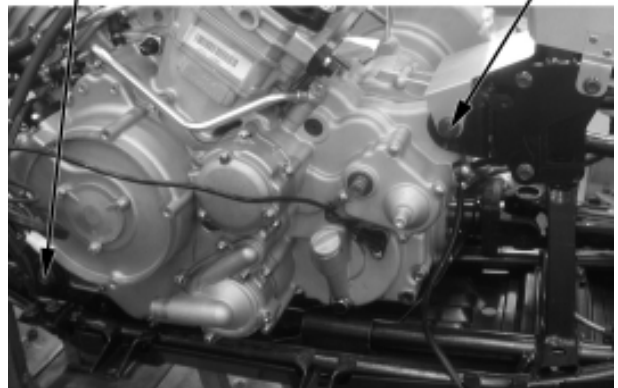

Remove engine mounting bolts(upper) no.5;

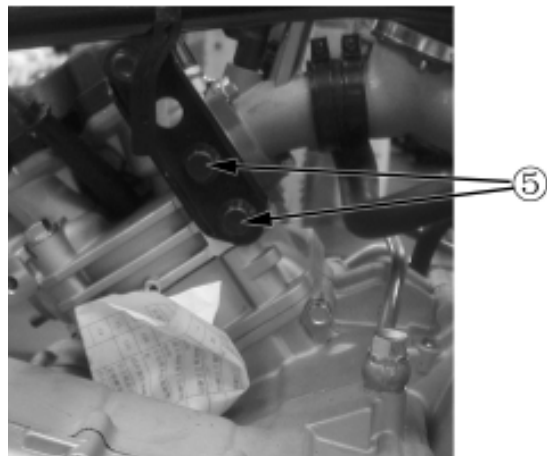

ENGINE INSTALLATION

After placing engine on the vehicle,install engine mounting bolts and nuts (front left) first,then (front right) and (rear).

Install engine inlet/outlet coolant hoses/oil pipes by clamps onto the engine.Connect starter motor positive/negative cables.

Connect all connectors.Install CVT breather duct,spark plug cap.Install shifting plate,air filter,throttle body and other removed parts.

FRONT/REAR GEARCASE REMOVAL AND INSTALLATION

Removal

Raise the vehicle off ground with jack.Ensure the vehicle would not tip or fall.

Remove plastics (→ **VEHICLE BODY AND MUFFLER**,Chapter 2);

Remove front/rear wheels and A-arms.

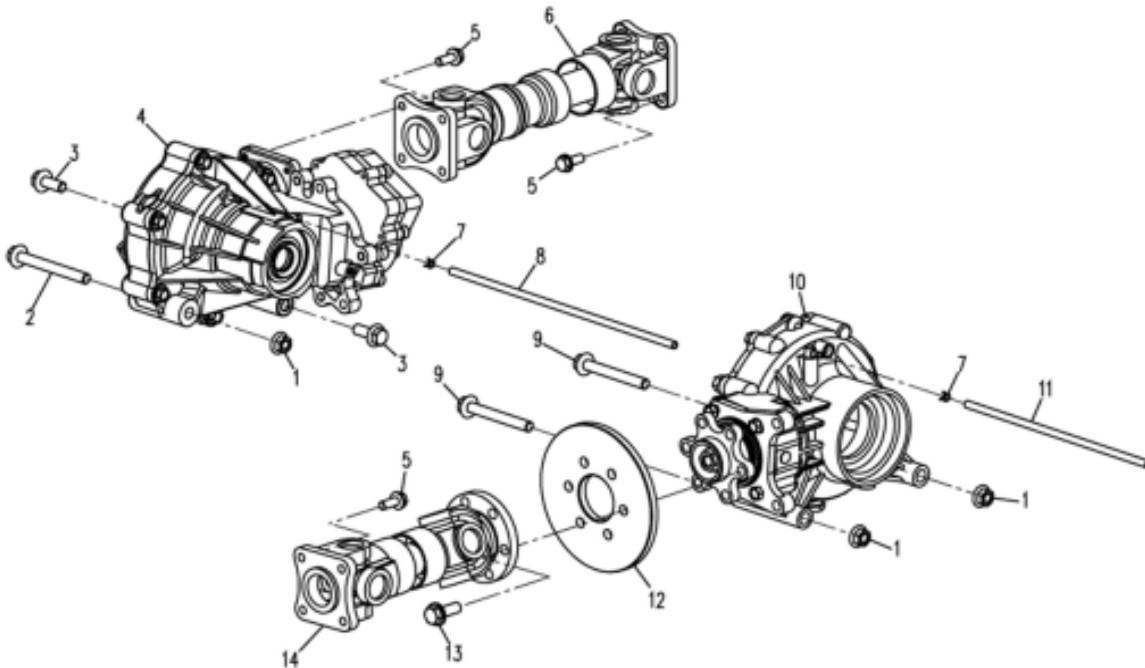

- 1.Nut 2.Bolt#1 3.Bit#2 4.Front Differential 5.Bolt#3 6.Front Propshaft 7.Clamp
8 . Front Differential Breather Hose 9.Bolt#4 10.Rear Gearcase 11.Rear Gearcase Breather Hose
12.Rear Brake Disc 13.Bolt#5 14.Rear Propshaft

5 ENGINE REMOVAL AND INSTALLATION

Remove front differential mounting bolts & nuts;

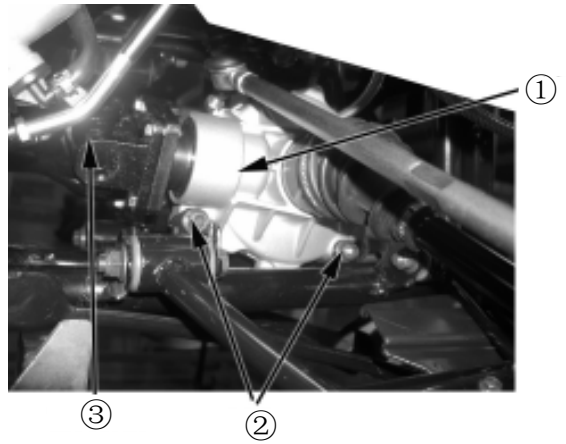

1. Front Differential 2. Bolts 3. Front Propshaft

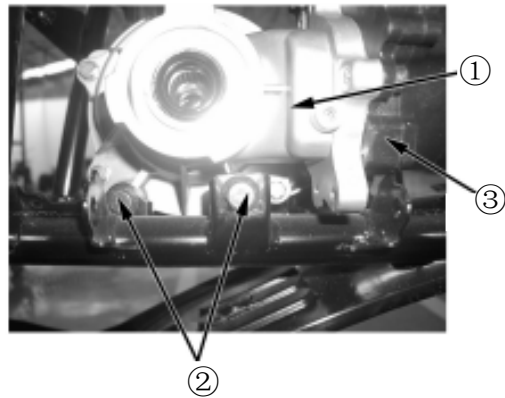

1. Front Differential 2. Bolts 3. Front Propshaft

Remove rear gearcase mounting bolts & nuts ;

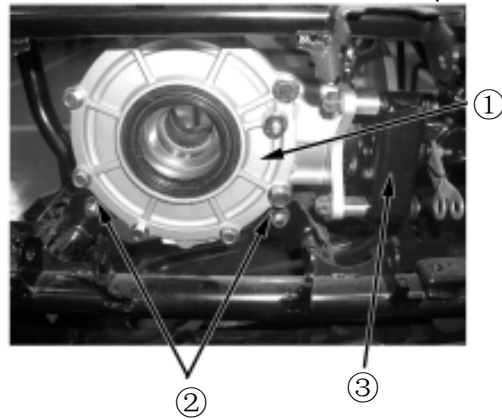

1. Rear Gearcase 2. Bolts 3. Rear Propshaft

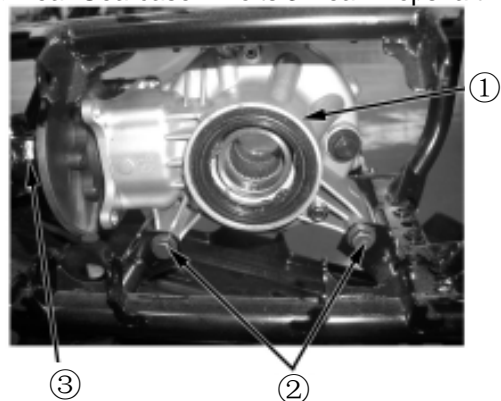

Remove the 18 bolts which connect propshafts and gearcases(see 5,bolt 3);

Remove propshafts,gearcases,and brake discs.

Installation

Reverse the removal procedure for installation.

Tightening Torque:

Front differential mounting bolt :40-50N•m

Rear gearcase mounting bolt :40-50N•m

Front and rear propshaft bolt :40-50N•m



①

1.Propshaft Bolts

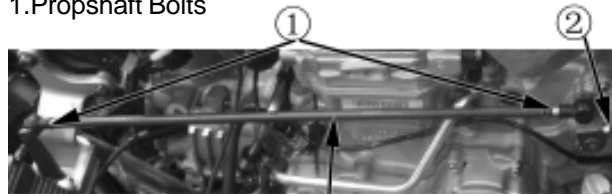

③

GEARSHIFT LINKAGE

Removal

Remove passenger seat(→2-4);

Remove driver seat(→2-4);

Remove air filter cover(→2-5);

Remove left side panel (→2-6);

Remove gearshift lever knob(→2-6);

Remove gearshift lever indicator(→2-6);

Remove bolt no.2 and shifting plate;

Loosen gearshift rod adjustment nuts no.1,remove gearshift rod;

Remove gearshift locking cable no.5;

Remove the 3 bolts of gearshift bracket and then remove the linkage.



⑤

⑥

Installation

Reverse the removal procedure for installation.

After installation,check gearshift linkage for smoothness and agility.If gearshifting sticks,adjust nuts no.1 to change the length of gearshift rod.

AIR INTAKE SYSTEM

SERVICE PRODUCTS

Description	Part Number	Page
Air Filter Cleaning Solution		03

AIR FILTER HOUSING

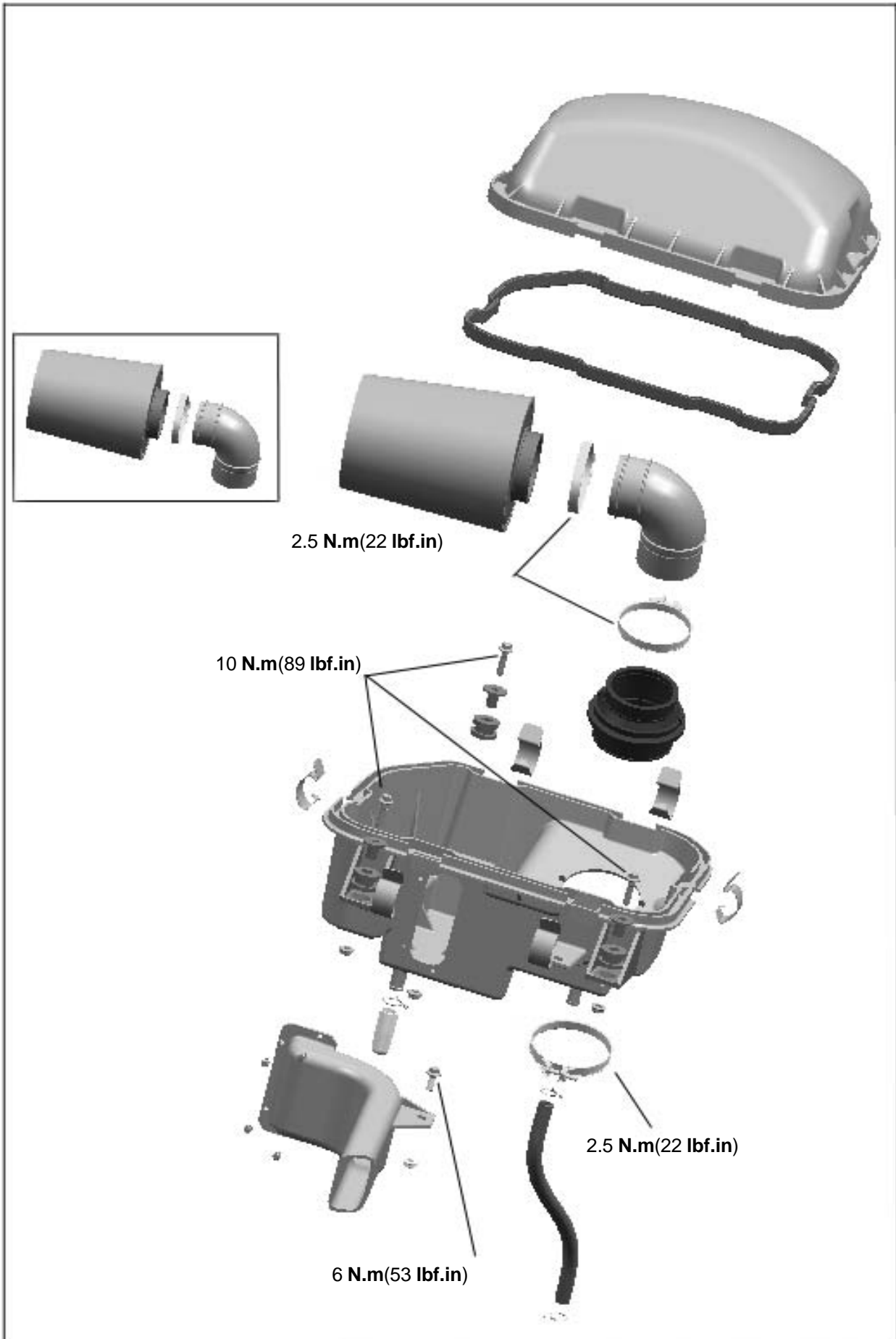

GENERAL

During assembly/installation, use the torque values and service products as in the exploded views. Clean threads before applying a threadlocker. Refer to **LUBRICANTS AND SERVICE PRODUCTS** at the beginning of this manual for complete procedure.

WARNING

Torque wrench must be used when tightening. Locking devices (e.g.: locking tabs, elastic stop nuts, cotter pin, etc.) must be replaced with new ones.

PROCEDURES

AIR FILTER

Air Filter Removal

CAUTION: Never remove or modify any component in the air filter housing. The engine management system is calibrated to operate specifically with these components. Otherwise, engine performance degradation or damage can occur.

Remove passenger seat, driver seat. Refer to **VEHICLE BODY AND MUFFLER**.

Release clamps and remove air filter cover.

Loosen clamps and remove air filter housing (upper).

NOTE: If vehicle is used in dusty area, inspect more frequently than specified in **MAINTENANCE CHART**. If liquid/deposits are found, squeeze and dry the foam filter. Replace filter element if damaged.

CAUTION: Do not start engine if liquid or deposit are found. If there is oil in the air filter housing, check engine oil level. Oil level may be too high.

Pour air filter cleaning solution or an equivalent into a bucket. Put the foam filter in to soak. Do not wash filter element.

While filter soaks, clean inside of air filter housing.

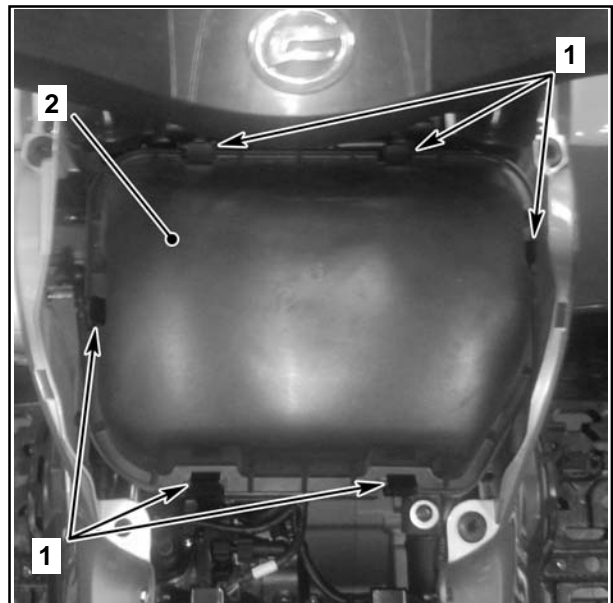

1. Clamps
2. Air Filter Housing

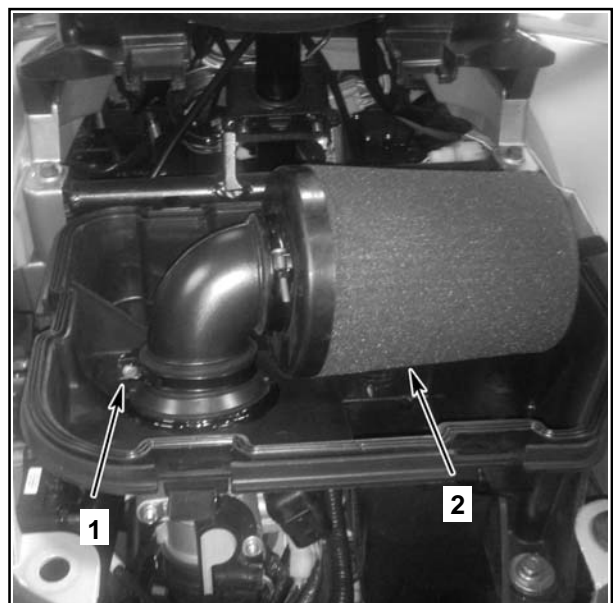

1. Clamp
2. Air Filter

Rinse foam filter with warm water and let it dry completely.

Blow low pressure compressed air on filter element to clean it.

Air Filter Installation

Properly reinstall removed parts in the reverse order of their removal.

AIR FILTER HOUSING

Air Filter Housing Removal

Remove seat, side panels;

Refer to **VEHICLE BODY AND MUFFLER**;

Loosen clamp and hose tie;

Disconnect breather hose;

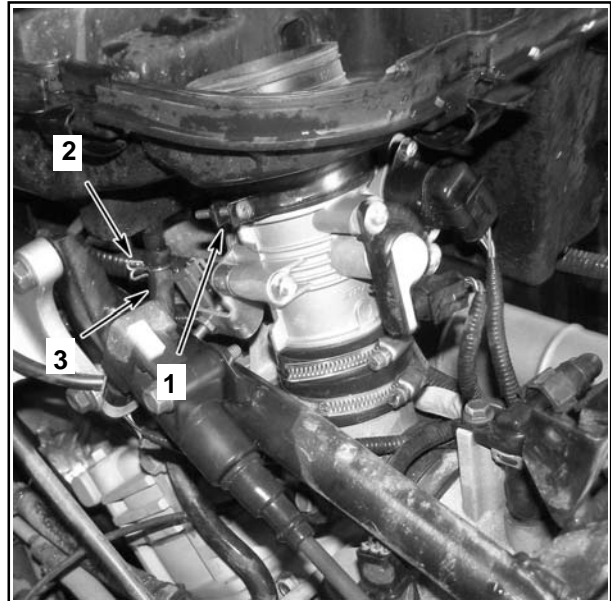

1.Clamp

2.Hose Tie

3.Breather Hose

Remove air filter housing mounting bolts;



1.Bolt

Pull air filter housing out.

Air Filter Housing Installation

Reverse the removal procedure for installation.

WARNING

Depress throttle lever several times to ensure it properly returns.



1.Bolt



1.Bolt

07 INTAKE MANIFOLD, CYLINDER HEAD AND CYLINDER

INTAKE MANIFOLD,CYLINDER HEAD AND CYLINDER

SERVICE TOOLS

Description	P/N	Page
Spark plug spacer	0800-022800-922-001	07
Camshaft locking tool	0800-024001-922-001	09
Crankshaft locking bolt	0800-041000-922-001	27
Valve spring compressor clamp	0180-022006-922-001	32
Valve guide remover	0800-022102-922-001	37
Valve guide installer	0800-022102-922-002	38
Piston ring compressor	0800-040003-922-001	41
Piston pin circlip installer	0800-040005-922-001	45

SERVICE PRODUCTS

Description	P/N	Page
Coolant		
Engine oil		
Loctite		38

INTAKE MANIFOLD

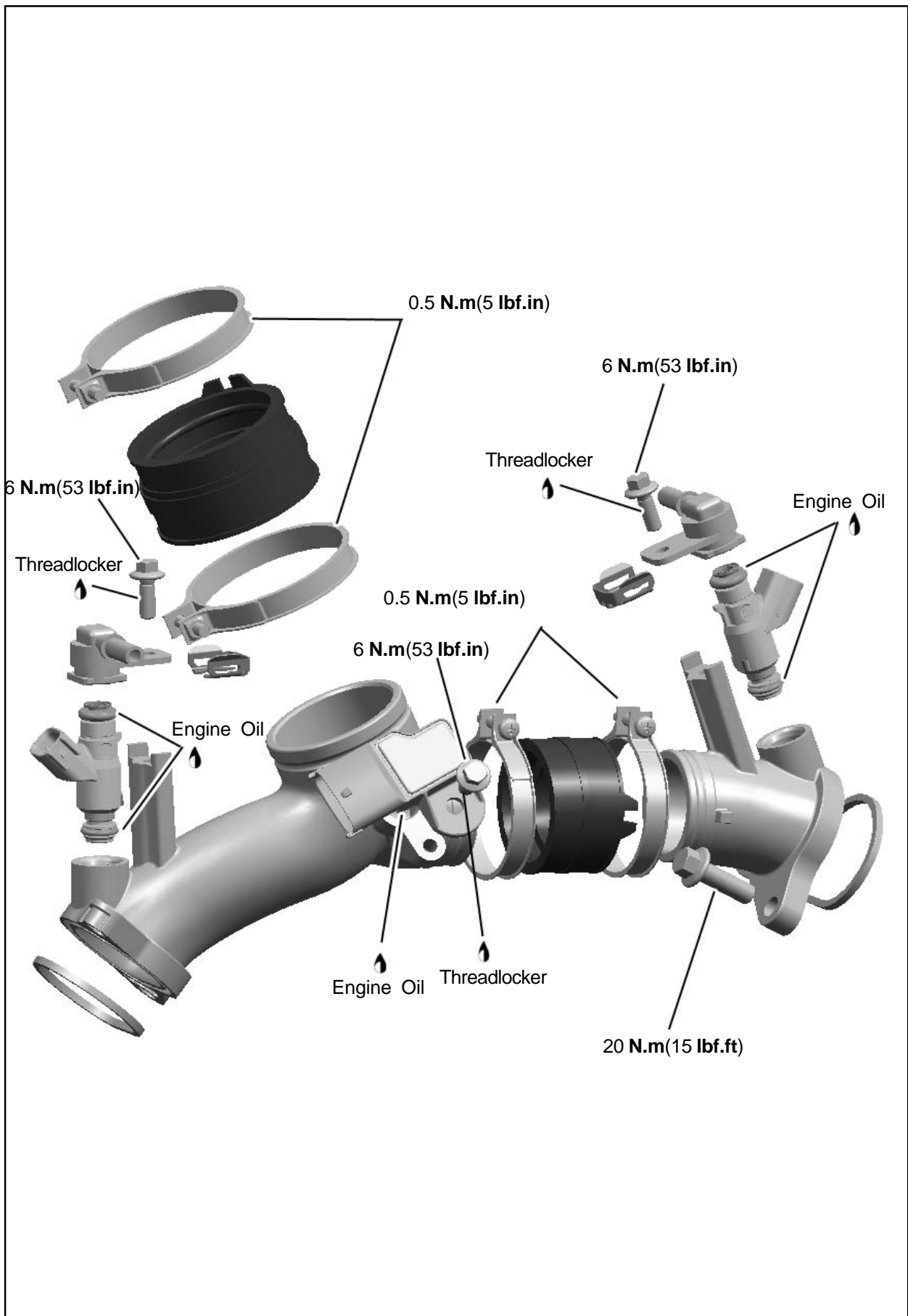

CYLINDER HEAD I

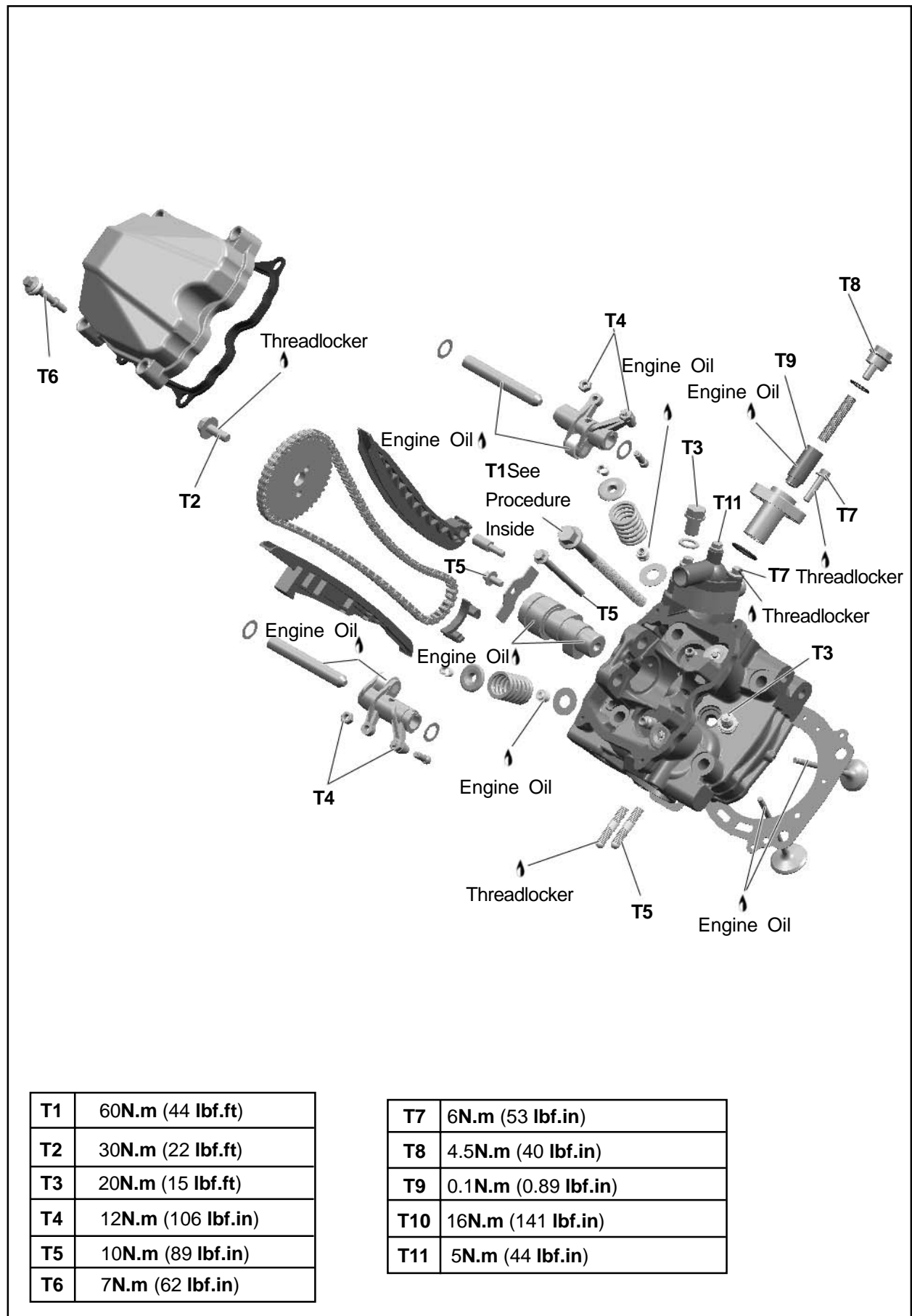

CYLINDER HEAD II

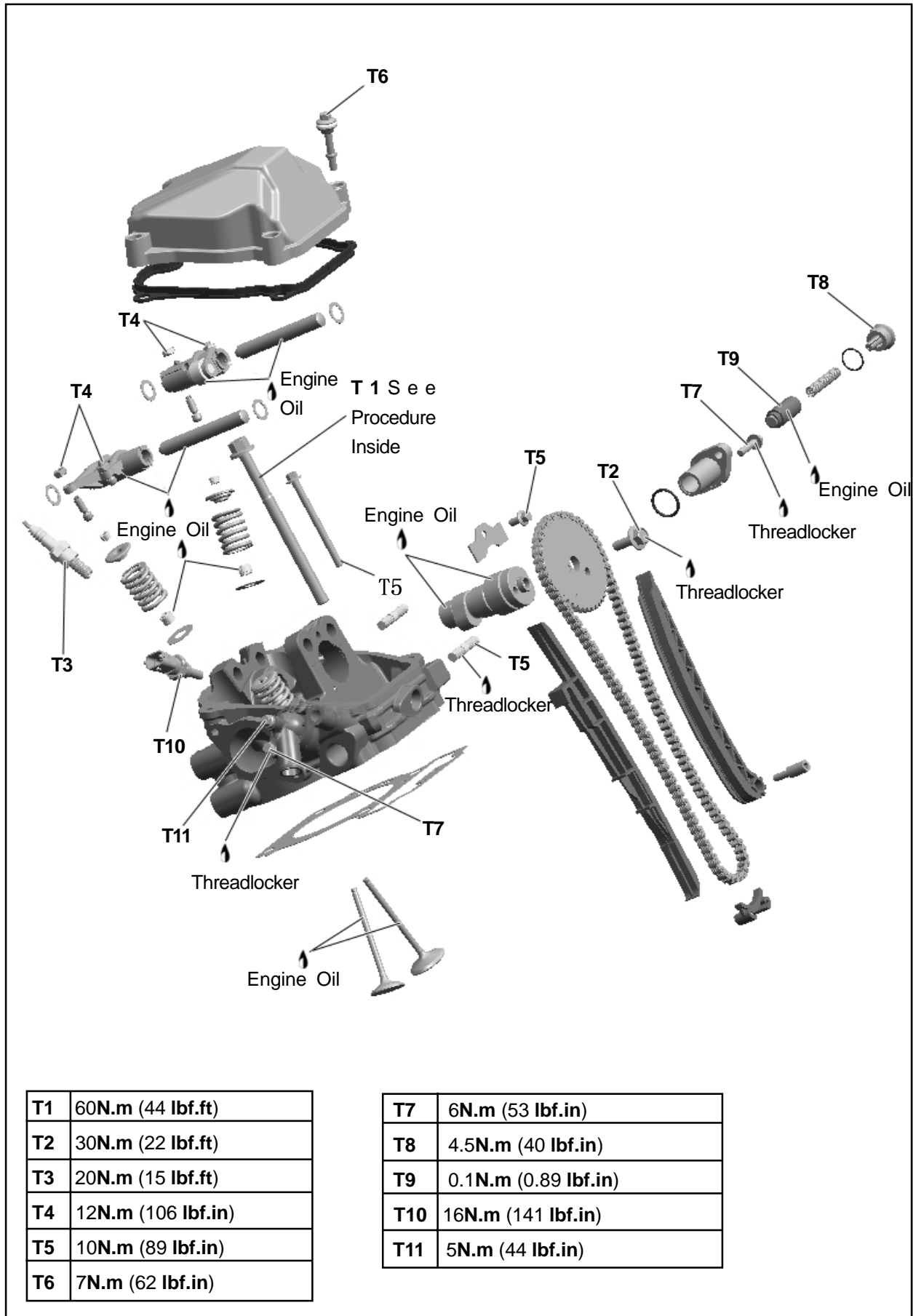

CYLINDERS AND PISTONS

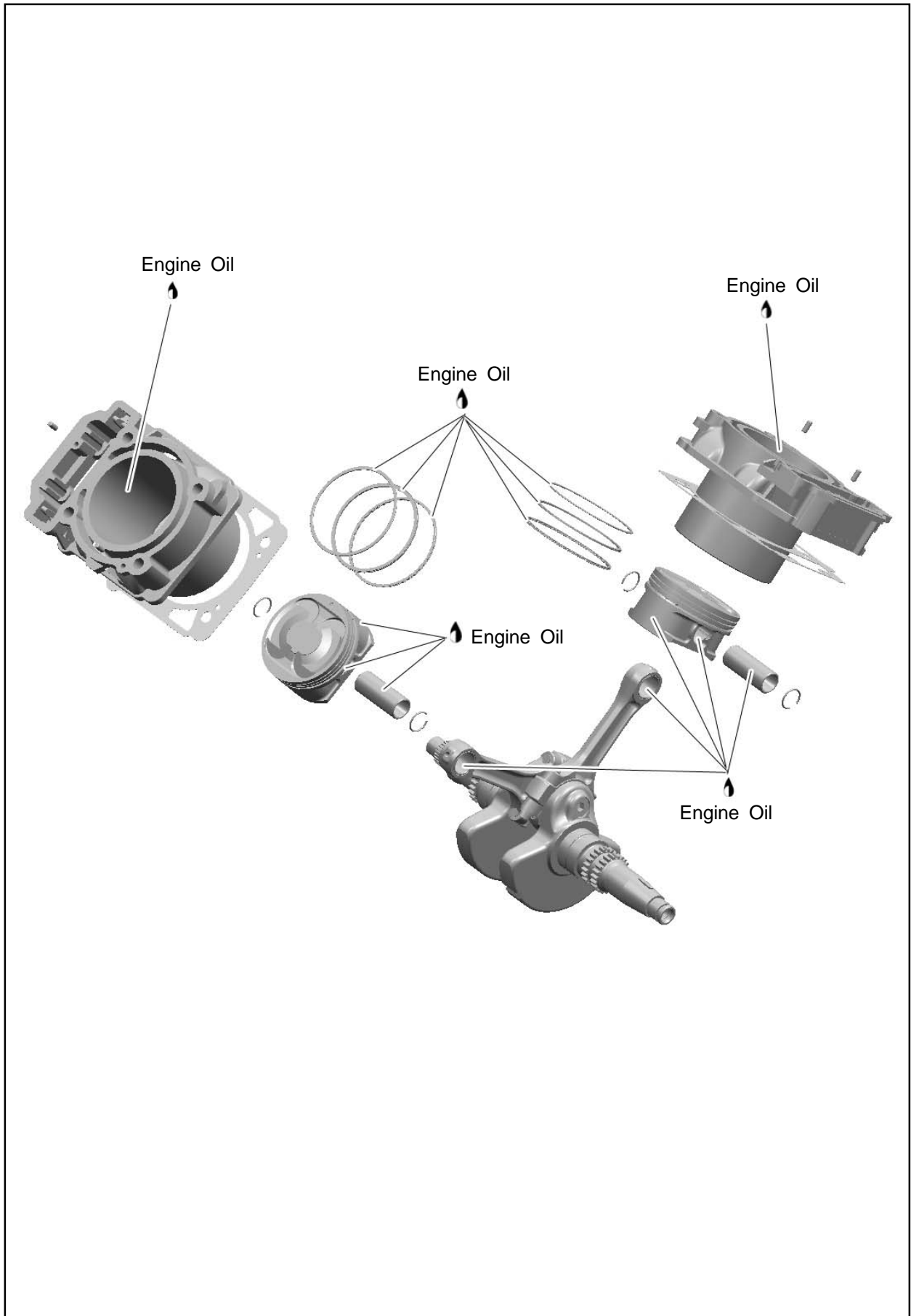

GENERAL

Components which are identical for both cylinders/cylinder heads are identified in the two exploded views by the same number. Components which are different or which are, for instance, present on one of the cylinders/cylinder heads but not on the other, have different numbers. The information given below always relates as a general rule.

Special reference is made in the text to work instructions which are not the same for cylinder no. 1 and cylinder no.2.

When diagnosing an engine problem, always diagnose cylinder 1 and 2 respectively.

Always place the vehicle on a level surface.

NOTE: For a better understanding, the many illustrations are taken with engine out of vehicle. To perform the following instructions if it is not necessary to remove engine from vehicle.

Always disconnect BLACK(-) cable from the battery, then RED(+) cable before working on the engine.

Even if the removal of many parts is not necessary to reach another part, it is recommended to remove these parts in order to check them.

During assembly/installation, use the torque values and service products as in exploded views.

Clean threads before applying a threadlocker. Refer to **LUBRICANTS AND SERVICE PRODUCTS** at the beginning of this manual for complete procedure.

WARNING

Torque wrench must be used when tightening. Locking devices(e.g.: locking tabs, elastic stop nuts,cotter pin,etc.)must be replaced with new ones.

When disassembling parts that are duplicated in the engine,(e.g.: valves), it is strongly recommended to note their position(PTO/MAG side, front/rear cylinder) and to keep them as a "group". If you find a defective component, it would be much easier to find the cause of the failure among its group of parts(e.g.: you found a worn valve guide. A bent spring could be the cause and it will be easy to know which one among the springs is the cause to replace it if you grouped them at disassembly). Also, since used parts have matched together during the engine operation, they will keep their matched fit when you reassemble them together within their "group".

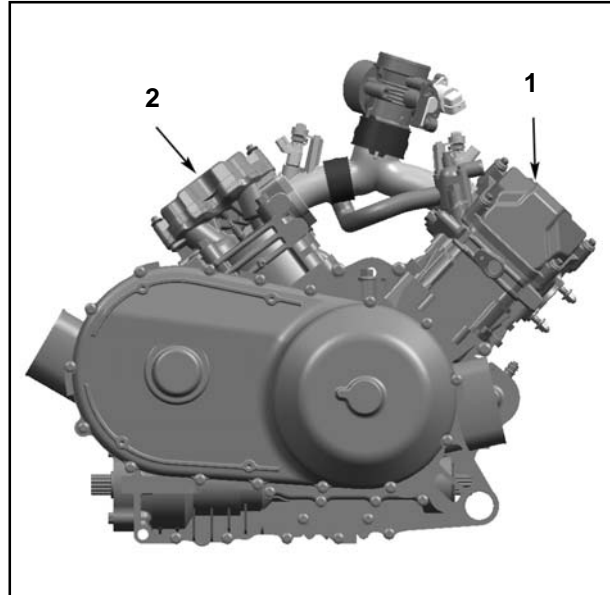

1.Cylinder 1 (Front)

2.Cylinder 2 (Rear)

MAINTENANCE

VALVE ADJUSTMENT

NOTE: Check and adjust valve clearance only when engine is cold.

Remove valve cover.

Before checking or adjusting the valve clearance, turn crankshaft to TDC ignition of the respective cylinder, see **CAMSHAFT**.

Use feeler gauge to check the valve clearance.

Valve Clearance	
Exhaust	0.11-0.19mm (0.0043-0.0075in)
Intake	0.06-0.14mm (0.0024-0.0055in)

If the valve clearance is out of specification, adjust valves as follows.

NOTE: Use mean valve of exhaust/intake to ensure a proper valve adjustment.

Hold the adjustment screw at the proper position and torque the locking nut.

Repeat the procedure for each valve.

Before installing valve cover, recheck valve clearance.

INSPECTION

LEAK TEST

Before performing the cylinder leak test, verify the following:

- clamp(s) tightness
- radiator and hoses

NOTE: For best accuracy, the leak test should be done with the engine at normal operating temperature.

WARNING

Prevent burning yourself on hot engine parts.

Preparation

Disconnect battery

WARNING

Always respect this order for disassembly; disconnect BLACK(-) cable first.

Remove radiator cap.

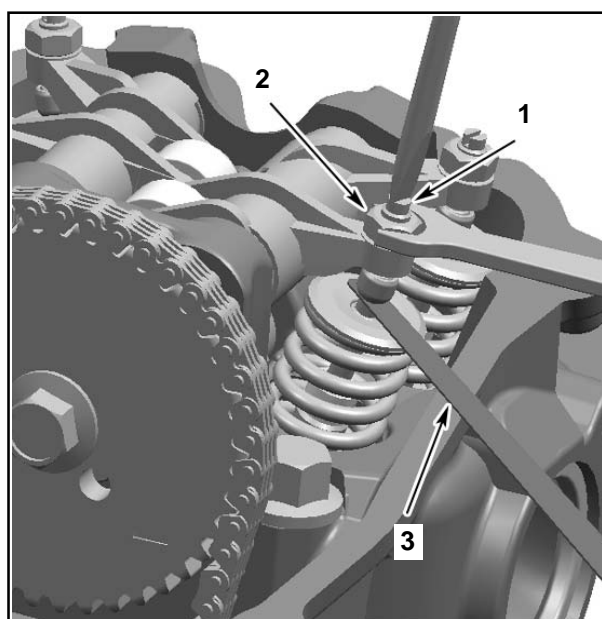

1. Adjustment Screw

2. Locking Nut

3. Feeler Gauge

WARNING

To prevent burning yourself only remove the radiator cap by wearing the appropriate safety equipment.

Remove any parts to have access to engine cylinder heads.

Unplug spark plug cable.

Clean spark plug area and remove spark plug from cylinder head.

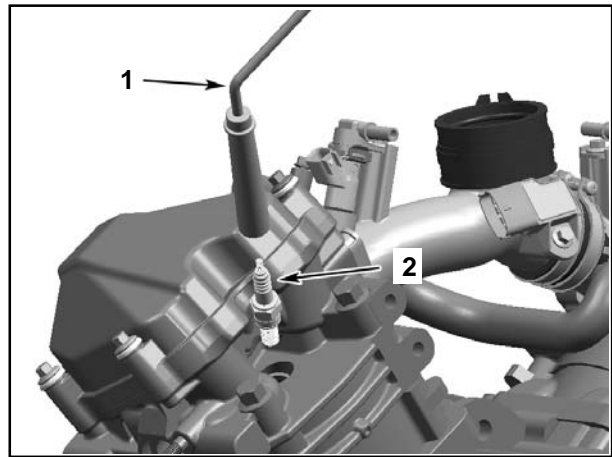

1. Spark Plug Cable

2. Spark Plug

Remove valve cover.

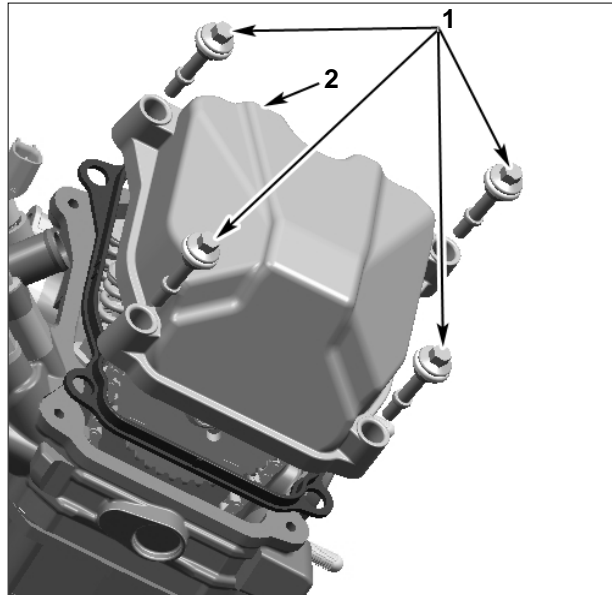

1. Valve Cover Screws

2. Valve Cover

Rotate crankshaft until piston is at ignition TDC(Refer to **CAMSHAFT TIMING** in this chapter).

Using the dial gauge, turn the crankshaft and set the piston to precisely ignition TDC.

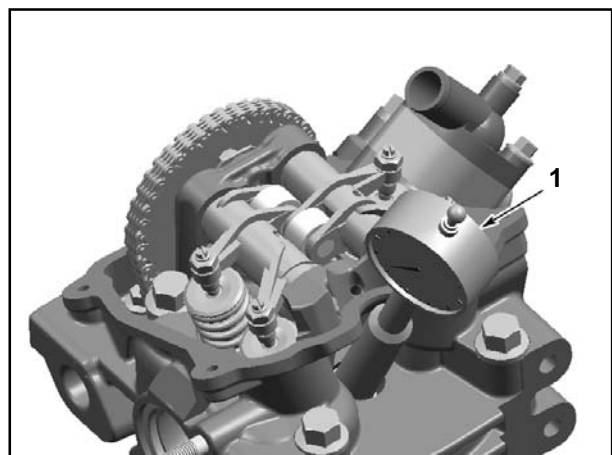

1. Dial Gauge

07 INTAKE MANIFOLD, CYLINDER HEAD AND CYLINDER

NOTE: If a dial gauge is not available, use a screwdriver or another similar suitable tool.

CAUTION: Do not scratch or damage piston/ cylinder surface.

NOTE: At ignition TDC the marks on the camshaft timing gear have to be parallel to cylinder head base as per following illustration.

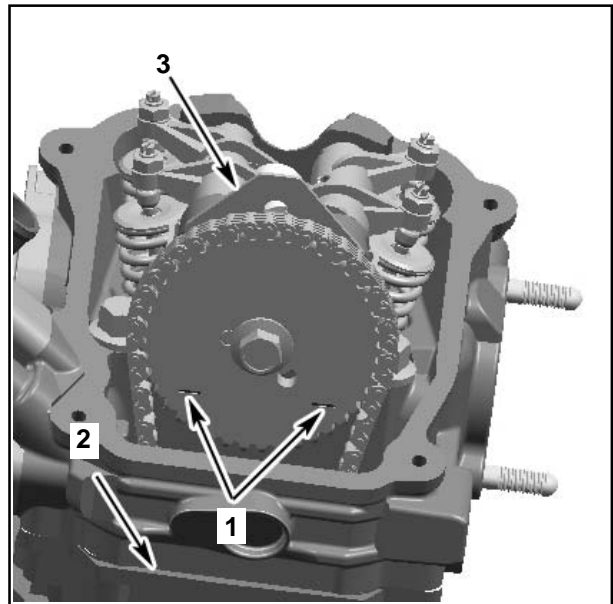

1. Marks on Camshaft Timing Gear
2. Cylinder Head Base
3. Camshaft Locking Tool

Lock camshaft at TDC by using camshaft locking tool (0800-024001-922-001).



Camshaft Locking Tool

LEAK TEST

Connect to adequate air supply.
Set needle of measuring gauge to zero.

NOTE: All testers have specific instructions on gauge operation and required pressure.

Install gauge adapter into previously cleaned spark plug hole.

Supply combustion chamber with air pressure.

Note the amount or percentage of leakage (depending on tester).

Leakage Percentage	Engine Condition
0% - 15%	Excellent condition
16% - 25%	Good condition
26% - 40%	Fair Condition
≥ 41%	Poor condition, diagnose and repair engine

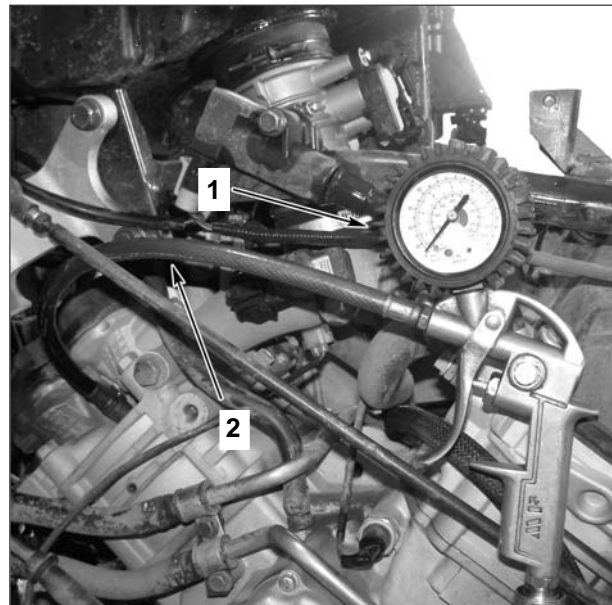

1. Leak Tester
2. Air Supply Hose

Diagnosis

Listen for air leaks:

-air escaping on intake port/throttle body means leaking intake valve(s)

-air escaping on exhaust port means leaking exhaust valve(s)

-air bubbles out of radiator means leaking cylinder head gasket

-air/oil escaping from crankcase means damaged gasket and/or loosened screws.

-air/coolant escaping from cylinder/head means damaged gasket(s) and/or loosened screws (refer to **INTAKE MANIFOLD, CYLINDER HEAD AND CYLINDER**)

-air escaping into crankcase area means excessively worn cylinder and/or broken piston rings (refer to **INTAKE MANIFOLD, CYLINDER HEAD AND CYLINDER**).

NOTE: For all the checkpoints mentioned above, see the appropriate engine section to diagnose and repair the engine.

Reassembly

Reverse the preparation procedure. Ensure to respect torque values and use of appropriate products/lubricants. Refer to exploded views in other sections of this manual as required.

PROCEDURES

INTAKE MANIFOLD

Intake Manifold Removal

Disconnect fuel pump control plug.

Release fuel pressure by running engine until it runs out of gas.

Remove seat, both side panels and fender. Refer to **VEHICLE BODY AND MUFFLER**.

WARNING

The fuel hose may be under pressure. Cover the fuel line connection with an absorbent rag. Slowly disconnect the fuel hose to release the pressure. Wipe off any fuel spillage.

Remove the cover of air filter housing.

Remove air filter.

Unscrew bolts securing the air filter housing to frame.

Unscrew the lower clamp retaining the manifold adapter between throttle body and intake manifold.

Remove the manifold adapter.

Unplug fuel lines from injectors.

Disconnect both injectors.

Disconnect the manifold air pressure temperature sensor (**T-MAP Sensor**).

Unscrew intake manifold from cylinders.

Remove intake manifold from vehicle.

Intake Manifold Inspection

Check intake manifold for cracks, warping at flanges or any other damage. Replace if necessary.

Intake Manifold Installation

The installation is the reverse of the removal procedure. However, pay attention to the following.

Torque manifold screws to **20N.m (15 lbf.ft)** one cylinder at a time.

Re-enable fuel pump control plug.

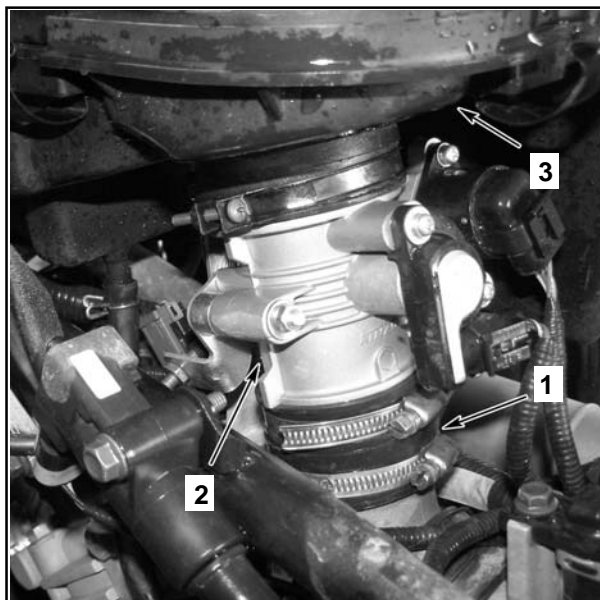

1. Manifold Adapter
2. Throttle Body
3. Air Filter Housing



1. Injector Connector
2. Fuel Line



1. T-MAP Sensor

VALVE COVER

Cover Removal

Remove distance screws of valve cover.

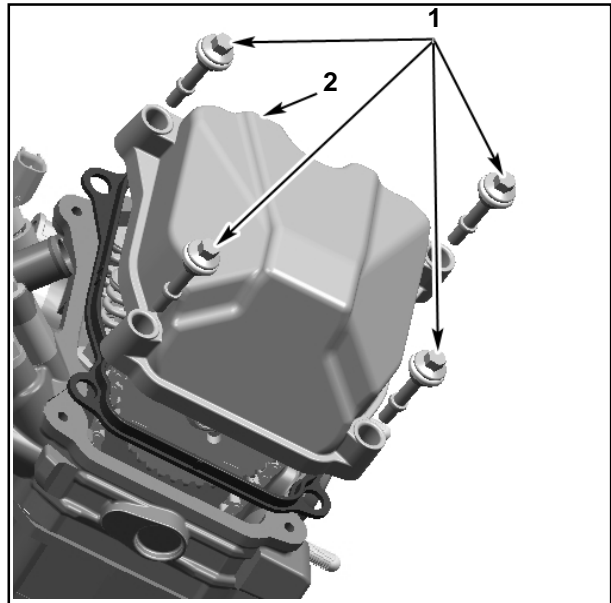

1. Distance Screws
2. Valve Cover

Remove valve cover and gasket.

Repeat the procedure for the other valve cover if required.

Cover Inspection

Check the gasket on the valve cover if it is brittle, cracked or hard. If so, replace the gasket.

Cover Installation

For installation, reverse the removal procedure. Torque the cylinder screws in a crisscross sequence.

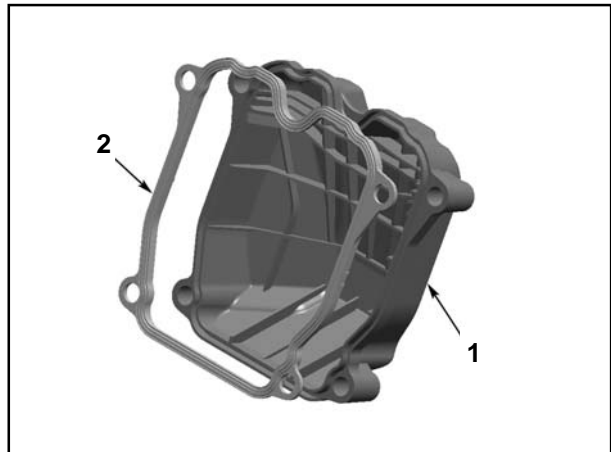

1. Valve Cover
2. Gasket

TIMING CHAIN TENSIONER

NOTE: Before removal and installation, make sure that the respective cylinder is set to TDC ignition. Refer to **CAMSHAFT**.

Tensioner Removal

WARNING

Timing chain tensioner is spring loaded. Never perform this operation immediately after the engine has been run because the exhaust system can be very hot. Wait until exhaust system is warm or cold.

Remove chain tensioner plug.
Unscrew chain tensioner plug.
Remove O-ring and spring.

Unscrew screws retaining chain tensioner housing.
Remove chain tensioner housing with O-ring.
Screw tensioner plunger into housing several turns.

Tensioner Inspection

Check the housing for cracks or other damages. Replace if any.
Check chain tensioner plunger for free movement and/or scoring.
Check if O-ring are brittle, cracked or hard. Replace if any.
Check spring condition. Replace if broken or worn.

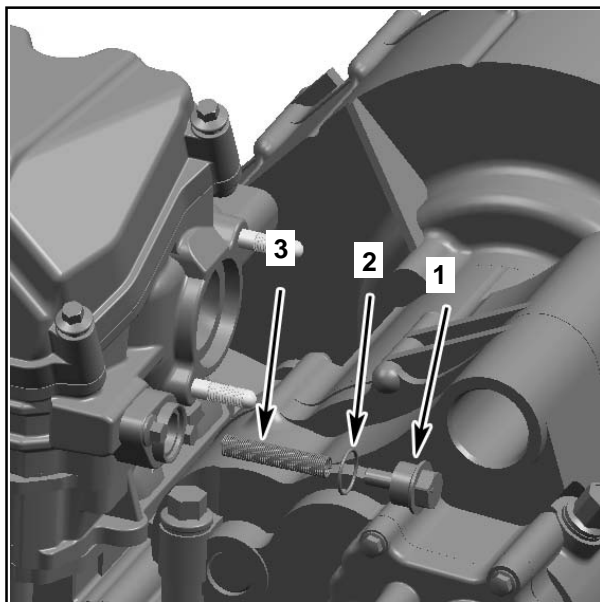

1.Chain Tensioner Screw
2.O-ring
3.Spring

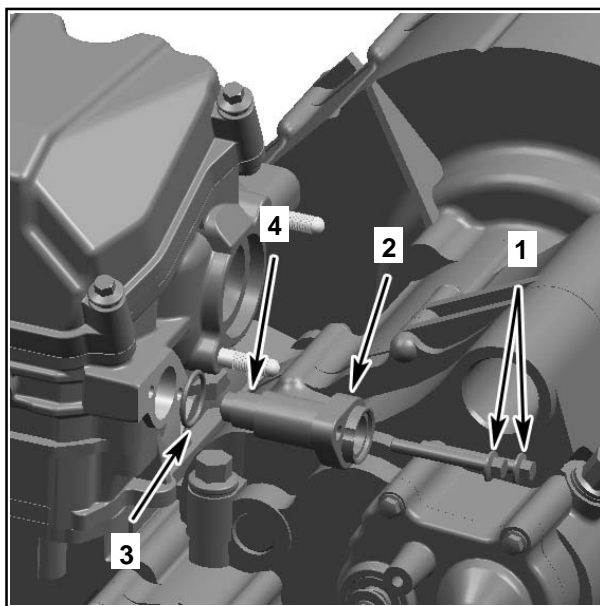

1.Chain Tensioner Screws
2.Chain Tensioner Housing
3.O-ring
4.Chain Tensioner Plunger

Tensioner Installation

For installation, reverse the removal procedure. However, pay attention to the following.

NOTE: Before installing the chain tensioner, make sure that the camshaft timing gear can be moved back and forth.

Apply engine oil on the plunger before installing.

NOTE: Slightly screw in the plunger until the timing chain allows no more back and forth movement of the camshaft timing gear. then screw in the plunger an additional 1/8 turn to reach the required torque of 0.1 N.m(0.9 lbf.in).

CAUTION: Improper adjustment of the timing chain will lead to severe engine damage.

Fit spring on one side into the slot of the plug screw and on the other side into the plunger. Turn spring only clockwise in order to fit the spring end into the notch of the plunger and to avoid loosening the plunger during spring installation. Do not preload the spring.

NOTE: Do not forget to place the O-ring on chain tensioner plug.

Then compress the spring and screw in the plug screw. Finally, tighten the plug screw to 4.5 N.m(40 lbf.in).

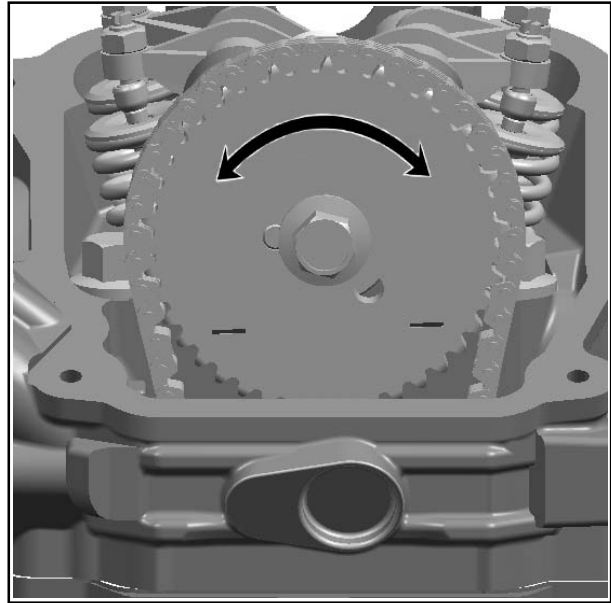

Move Gear Back and Forth

CAMSHAFT TIMING GEAR

Gear Removal

Remove valve cover.

Turn crankshaft to TDC ignition of the respective cylinder, see **CAMSHAFT**.

Unscrew timing chain tensioner.

Remove camshaft timing gear screw.

To prevent timing chain stretching during removal of camshaft timing gear screw, use the camshaft locking tool(0800-024001-922-001).

Remove camshaft timing gear.

NOTE: *Secure timing chain with a retaining wire.*

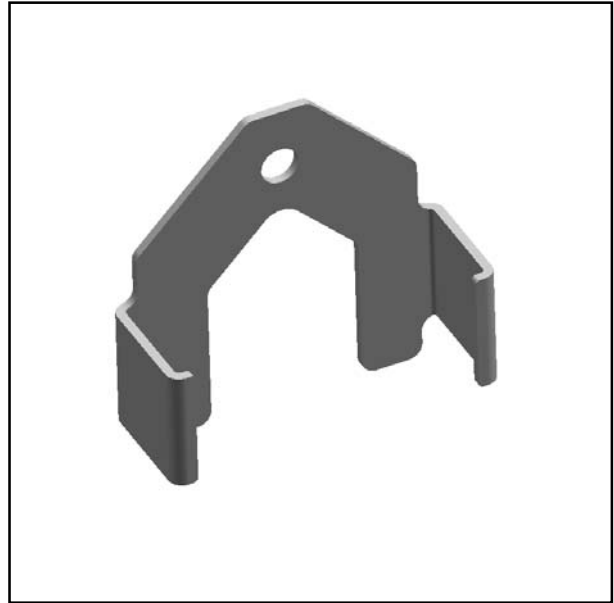

Camshaft Locking Tool

Gear Inspection

Check camshaft timing gear for wear or deterioration.

If gear is worn or damaged, replace it as a set (camshaft timing gear and timing chain).

For crankshaft gear, refer to Chapter 8, see **CRANKSHAFT**.

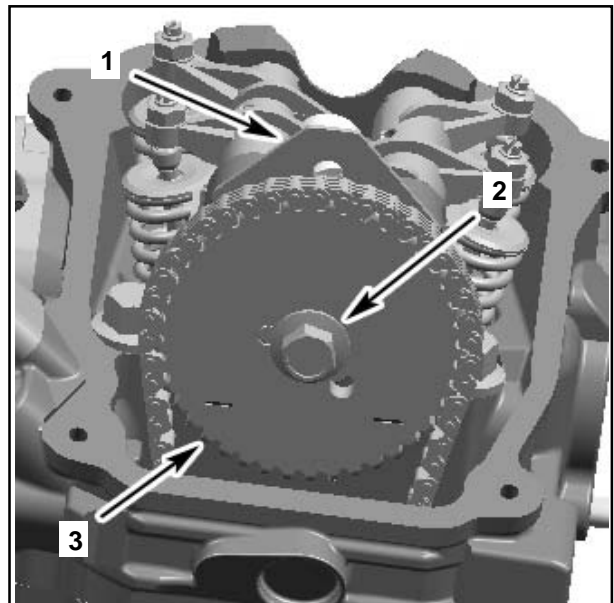

1. *Camshaft Locking Tool*
2. *Camshaft Timing Gear Screw*
3. *Camshaft Timing Gear*

Gear Installation

For installation, reverse the removal procedure. Pay attention to the following details.

Clean mating surface and threads of camshaft prior to assembling camshaft timing gear.

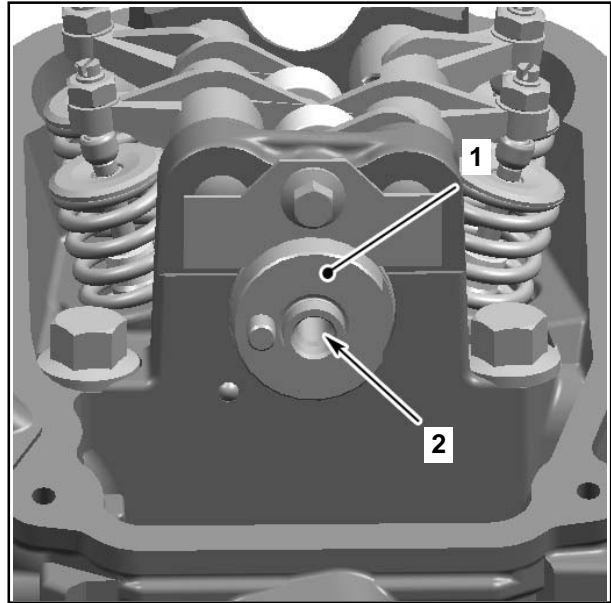

- 1. Mating Surface on Camshaft
- 2. Threads for Camshaft Screw

07 INTAKE MANIFOLD, CYLINDER HEAD AND CYLINDER

Camshaft timing gear and crankshaft must be at TDC ignition before installing the timing chain.

CAUTION: Crankshaft and camshaft must be locked on TDC ignition position to place camshaft timing gear and timing chain in the proper position.

The printed marks on the camshaft timing gear must be parallel to the cylinder head base. See the following illustration for a proper positioning.

When the camshaft timing gear and the timing chain are installed, remove the crankshaft locking bolt as well as the camshaft locking tool.

NOTE: Before installing the camshaft screw adjust the chain tensioner (see **CHAIN TENSIONER** below) and check again if marks on the timing gear are parallel to cylinder head base.

Reinstall all other removed parts.

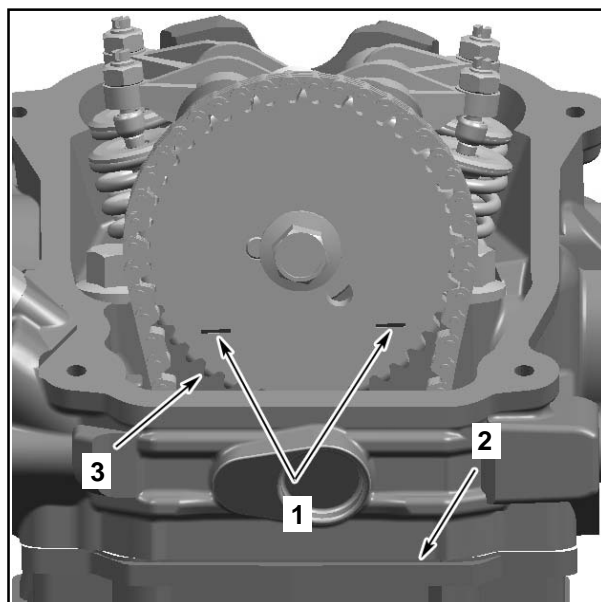

1. Marks on Camshaft Timing Gear
2. Cylinder Head Base
3. Camshaft Timing Gear

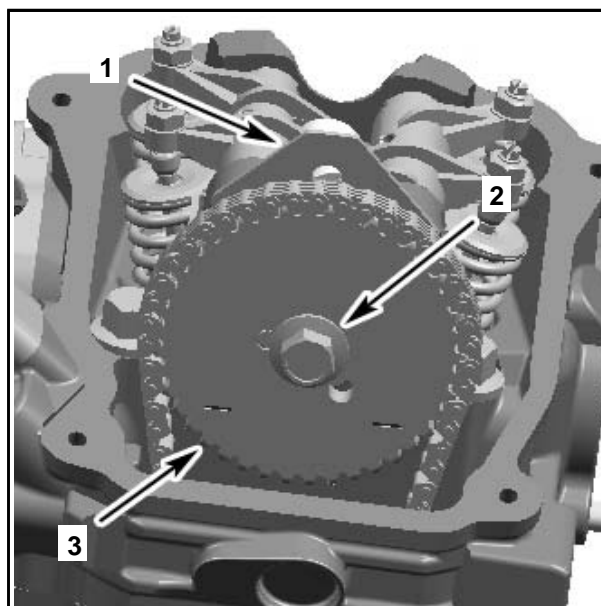

1. Camshaft Locking Tool
2. Camshaft Screw
3. Camshaft Timing Gear

ROCKER ARM

Rocker Arm Removal

Remove valve cover.

Remove chain tensioner and camshaft timing gear.

Remove screw and camshaft retaining plate.

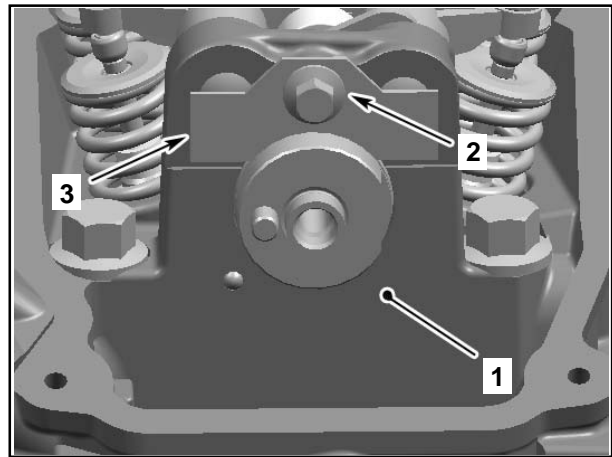

1. Cylinder Head

2. Screw

3. Camshaft Retaining Plate

Remove rocker arm shafts.

Remove rocker arm assembly (exhaust side and intake side) with adjustment screws and nuts.

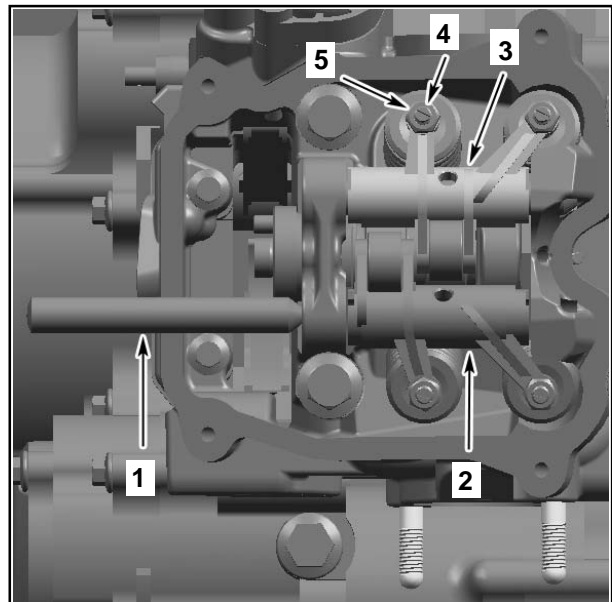

1. Rocker Arm Shaft

2. Rocker Arm, Exhaust

3. Rocker Arm, Intake

4. Adjustment Screw

5. Locking Nut

07 INTAKE MANIFOLD, CYLINDER HEAD AND CYLINDER

Remove thrust washers.

CAUTION: Pay attention not to lose thrust washers or drop them into the timing chain compartment.

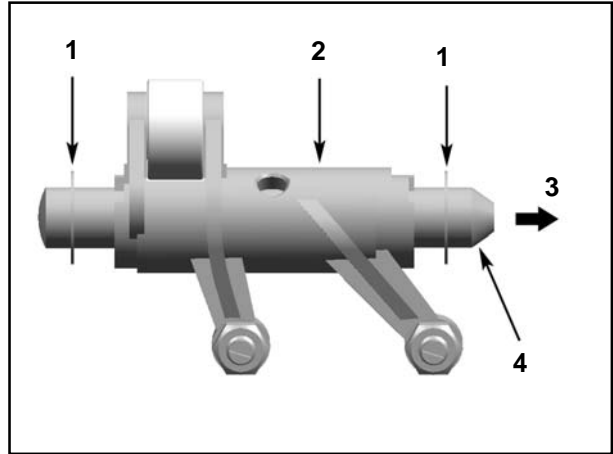

- 1.2 Thrust Washers
- 2. Rocker Arm, Exhaust
- 3. Cylinder Head—Spark Plug Side
- 4. Big Taper to Spark Plug Side

Rocker Arm Inspection

Inspect each rocker arm for cracks and scored friction surfaces. If any, replace rocker arm assembly. Check the rocker arm rollers for free movement, wear and excessive radial play. Replace rocker arm assembly if necessary.

Check rocker arm bore diameter. If diameter is out of specification, change rocker arm assembly.

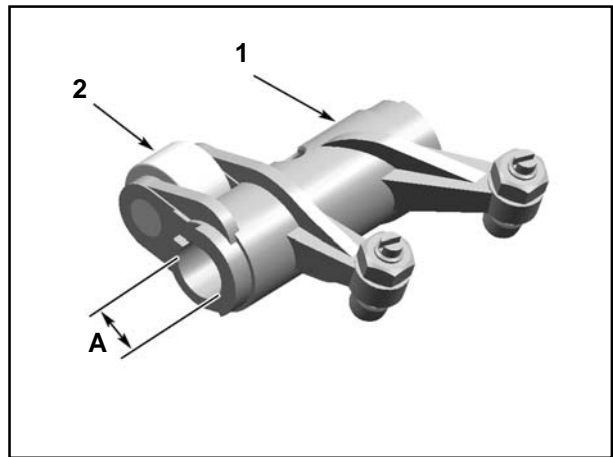

- 1. Rocker Arm, Exhaust
- 2. Roller
- A. Bore for Rocker Arm Shaft

Rocker Arm Bore Diameter	
New	12.000-12.018mm (0.4724-0.4731 in)
Service Limit	12.030mm (0.4736 in)

Check adjustment screws for free movement, cracks and/or excessive play.

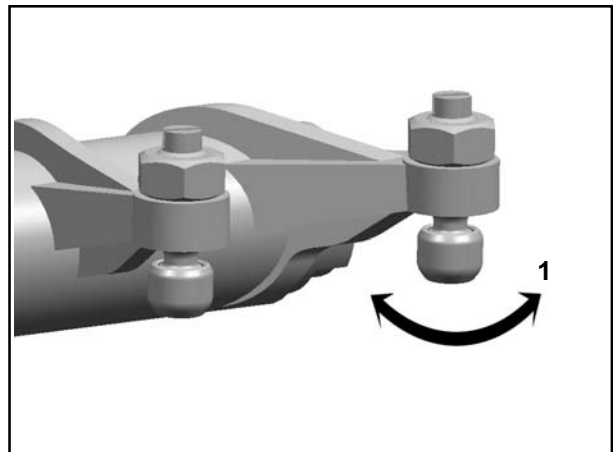

- 1. Free Movement of Adjustment Screw Top

Rocker Arm Shaft

Check for scored friction surfaces; if any, replace parts.
Measure rocker arm shaft diameter.

Rocker Arm Shaft Diameter	
New	11.973-11.984mm (0.4714-0.4718in)
Service Limit	11.960mm(0.4709in)

Any area worn excessively will require parts replacement.

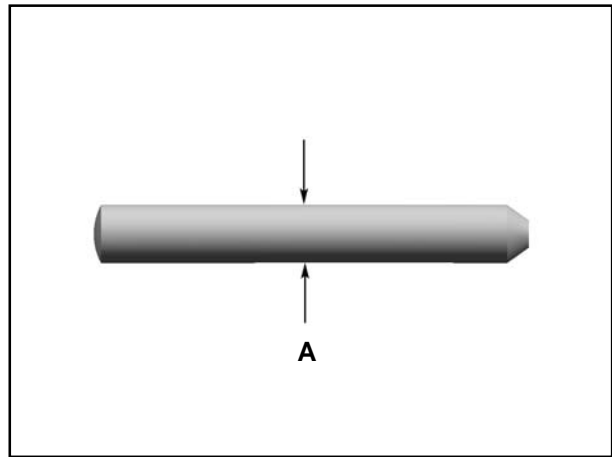

A. Measure rocker arm shaft diameter here

Rocker Arm Installation

NOTE: Use the same procedure for exhaust and intake rocker arm.

Apply engine oil on rocker arm shaft.

Install the rocker arm shaft with the chamfered edge first and use following procedure.

Insert a rocker arm pin through rocker arm pin bore.

Install a thrust washer then proper rocker arm(exhaust side)or (intake side).

Push in rocker arm shaft until its chamfer reaches the end of rocker arm bore.

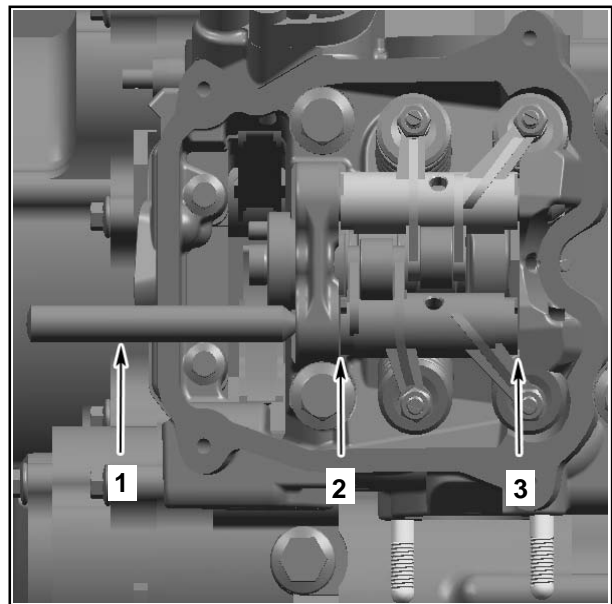

1. Rocker Arm
2. Thrust Washer (Timing Chain Side)
3. Thrust Washer (Spark Plug Side)

Place the other thrust washer and push rocker arm shaft to end position.

TIMING CHAIN

Refer to Chapter 8, see **TIMING CHAIN**.

CYLINDER HEAD

Cylinder Head Removal

The removal procedure is the same for both cylinder heads.

Drain coolant(refer to **COOLING SYSTEM**).

NOTE: Before removing cylinder head, blow out remaining coolant by air pressure. During cylinder head removal, the remaining coolant in cylinder head could overflow into the engine and a little quantity of coolant could drop into engine. In this case, the engine oil will be contaminated.

Disconnect spark plug wire.

Disconnect temperature sensor connector, located at rear cylinder head.

Remove both side panels and both inner fenders(refer to **VEHICLE BODY AND MUFFLER**).

Remove exhaust pipe springs or exhaust pipe clamp.

Unscrew exhaust pipe nuts

Unplug radiator inlet hose.

Remove air filter.

Remove throttle body.

Remove the intake manifold(see **INTAKE MANIFOLD** above).

Remove the chain tensioner(see **CHAIN TENSIONER** above).

Remove the valve cover and its gasket(see **VALVE COVER** above).

Remove the camshaft timing gear.

Unscrew cylinder head screws M6 and M10 retaining cylinder head and cylinder to cylinder base.

Pull up cylinder head.

Remove chain guide.

Remove the cylinder head gasket and scrap it.

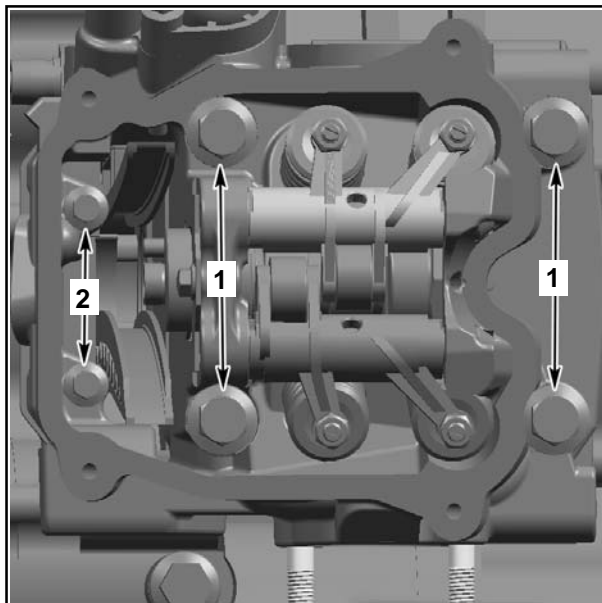

1. Cylinder Head Screws M10

2. Cylinder Head Screws M6

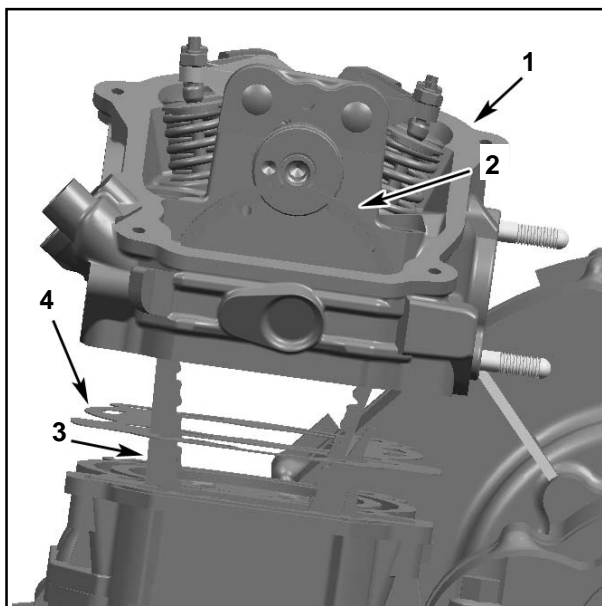

1. Cylinder Head

2. Timing Chain

3. Chain Guide

4. Cylinder Head Gasket

Cylinder Head Inspection

Inspect timing chain guide for wear, cracks or other damages, Replace if any.

Check for cracks between valve seats, if any, replace cylinder head.

Check mating surface between cylinder and cylinder head for contamination, if any, clean both surfaces.

Clean oil support through the cylinder head from contamination.

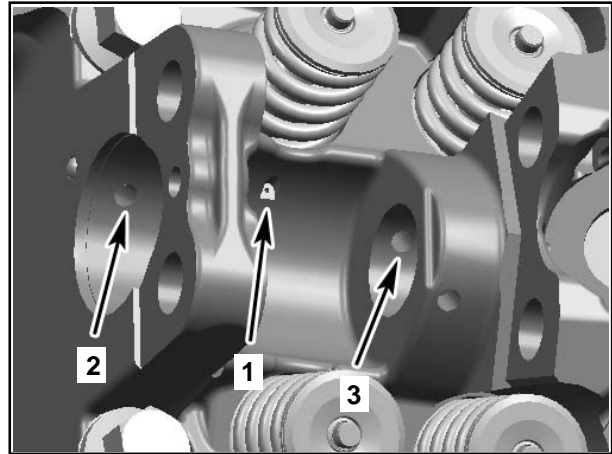

- 1.Oil Port to lubricate Camshaft Lobes Intake/Exhaust
- 2.Oil Supply to Camshaft Bearing Journal Timing Chain Side
- 3.Oil Supply to Camshaft Journal Spark Plug Side

Cylinder Head Installation

NOTE: *The cylinder heads are not identical in design. Do not invert the cylinder heads at assembly.*

For installation, reverse the removal procedure. Pay attention to the following details.

Ensure dowel pin are in place.

CAUTION: Chain guide has to be fixed between cylinder and cylinder head.

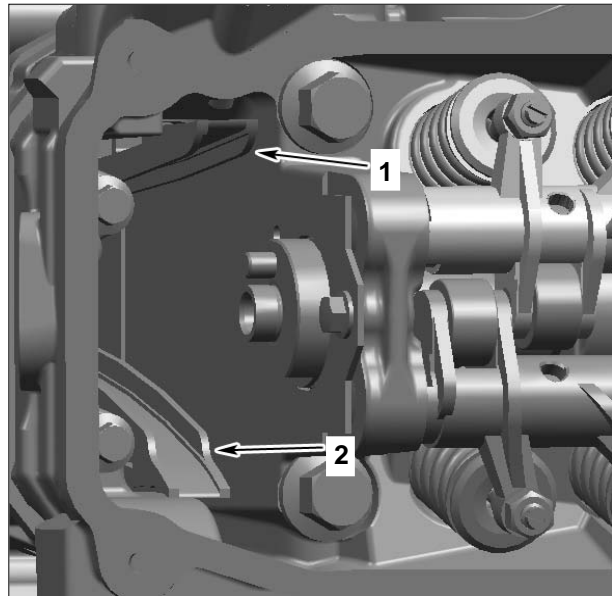

- 1.Chain Guide(fiixed between cylinder and cylinder head)
- 2.Chain Tensioner Guide(mounted in Crankcase)

07 INTAKE MANIFOLD, CYLINDER HEAD AND CYLINDER

Install a **NEW** cylinder head gasket.

First, torque cylinder head screws M10 in crisscross sequence to 20N.m(15 lbf.ft), then finish by tightening to 60N.m(44 lbf.ft).

Install cylinder head screws M6.

Check chain guide for movement.

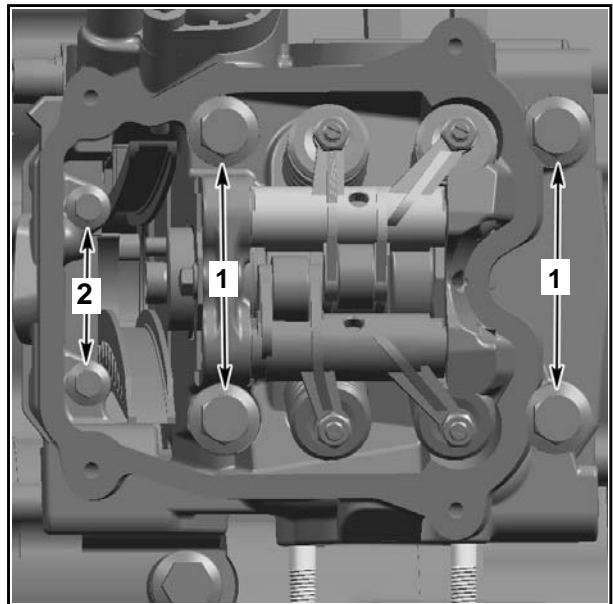

1.Cylinder Head Screws M10

2.Cylinder Head Screws M6

CAMSHAFT

NOTE: The engine is equipped with two different camshafts.

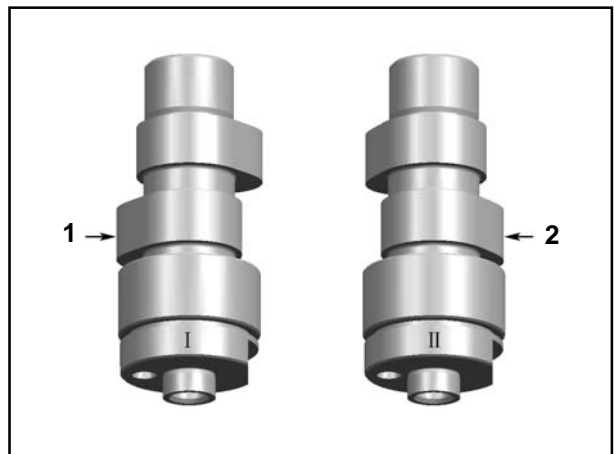

1.Camshaft of Cylinder 1

2.Camshaft of Cylinder 2

Camshaft Timing

NOTE: If a piston (of cylinder 1 or 2) is set to TDC ignition, the camshaft timing gear of the opposite cylinder must be in the following position.

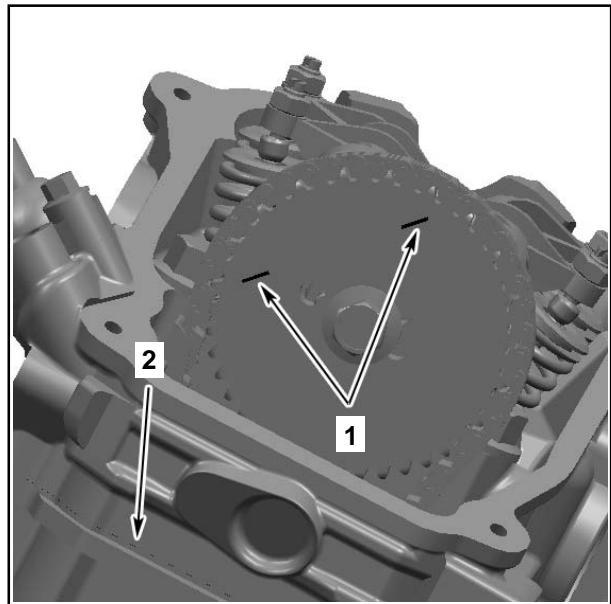

1. Marks on Timing Gear of Opposite Cylinder
2. Cylinder Head Base

Camshaft Timing Cylinder 2

Turn crankshaft until piston is at TDC ignition as follows

- Remove spark plug of both cylinders.
- Remove valve cover of both cylinders.
- Remove plug screw cover.

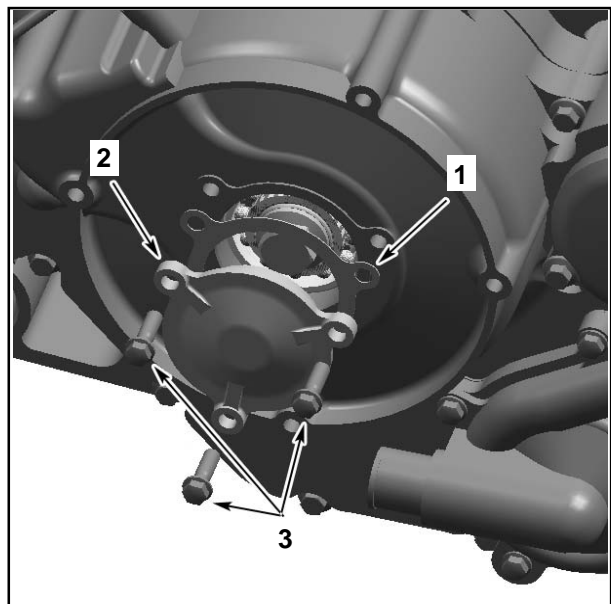

1. Gasket
2. Cover
3. Screws

07 INTAKE MANIFOLD, CYLINDER HEAD AND CYLINDER

Remove the crankshaft position sensor (CPS).

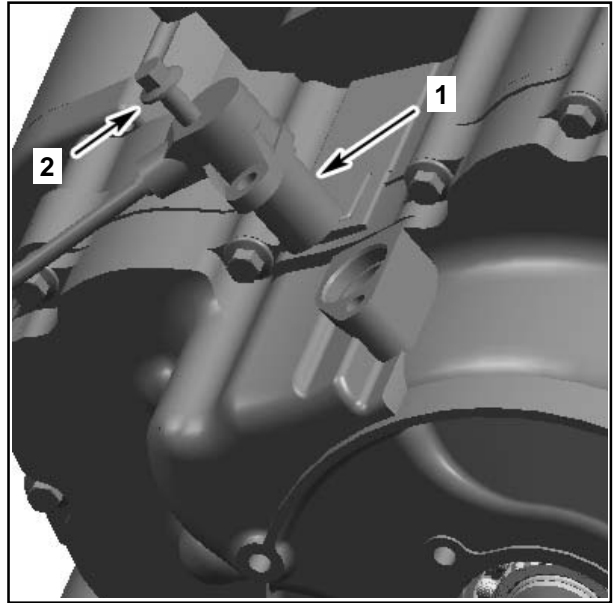

- 1. Crankshaft Position Sensor(CPS)
- 2. Screw

Use a 18mm socket to turn crankshaft until piston 2 (rear) is at TDC ignition.

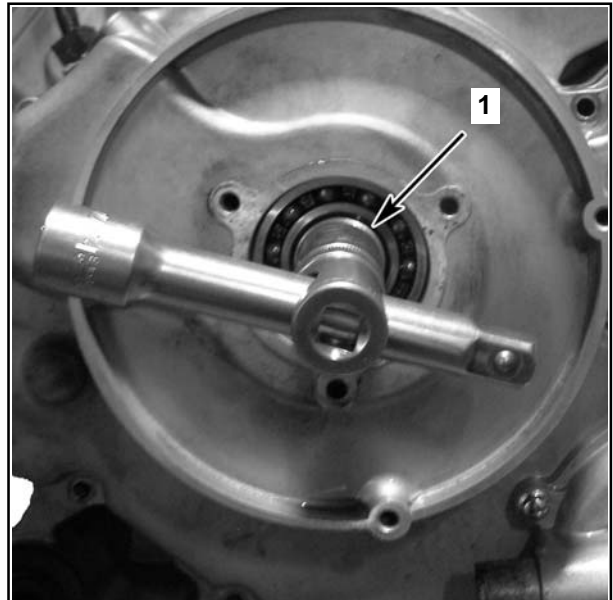

- 1. 18mm Socket

When rear piston is at TDC ignition, marks on mag-
neto flywheel” 2 “and on the left crankcase cover(centre
of bore) are aligned.

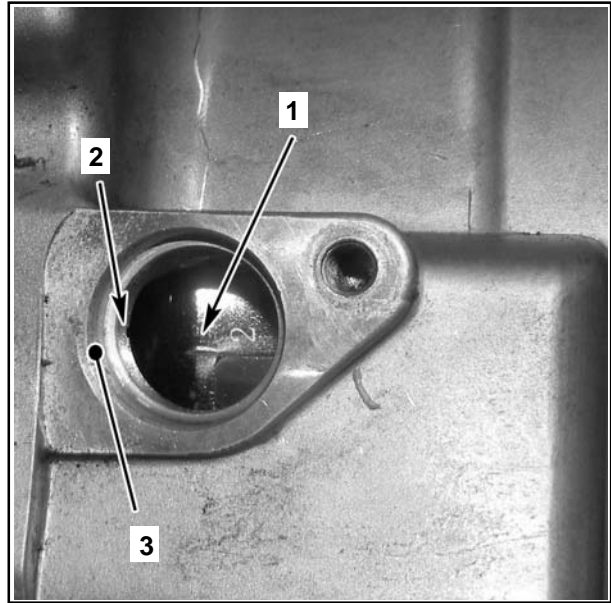

- 1.Mark “2” on MAG Flywheel
- 2.Notch on MAG Cover
- 3.CPS Location

At TDC ignition, the printed marks on the camshaft
timing gear have to be parallel to cylinder head base.

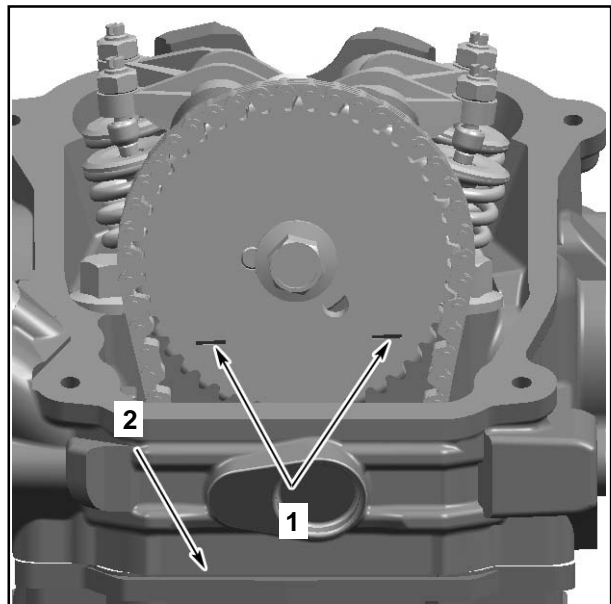

- 1.Marks on Camshaft Timing Gear
- 2.Cylinder Head Base

07 INTAKE MANIFOLD, CYLINDER HEAD AND CYLINDER

To lock crankshaft at TDC ignition, proceed as follows.
Remove from crankcase plug screw with sealing ring.

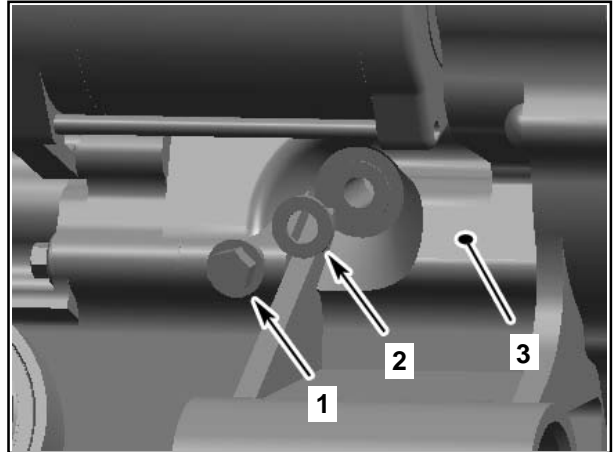

1. Plug Screw
2. Sealing Ring
3. Crankcase PTO Side, Front Side

Lock crankshaft with the crankshaft locking bolt (0800-041000-922-001).

NOTE: Make sure the locking bolt engages in the groove of the crankshaft.

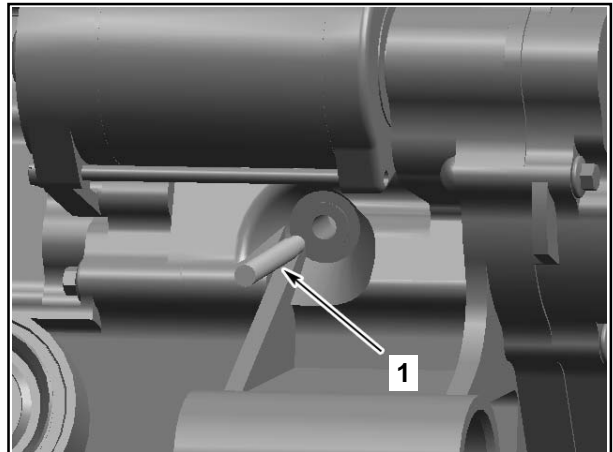

1. Crankshaft Locking Bolt

Camshaft Timing Cylinder 1

Turn cylinder 2 to TDC ignition, see *Camshaft Timing, Cylinder 2*.

NOTE: Do not lock crankshaft.

Use a 18mm socket, turn crankshaft 280° counterclockwise, until marks on magneto flywheel and left crankcase cover are aligned.

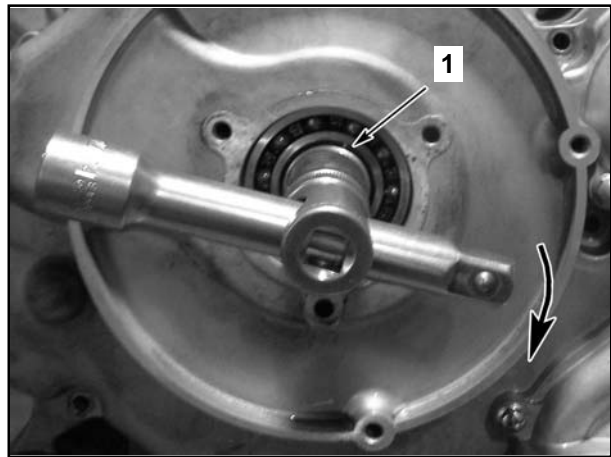

1. 18mm Socket

2. Turn Crankshaft 280° Counterclockwise

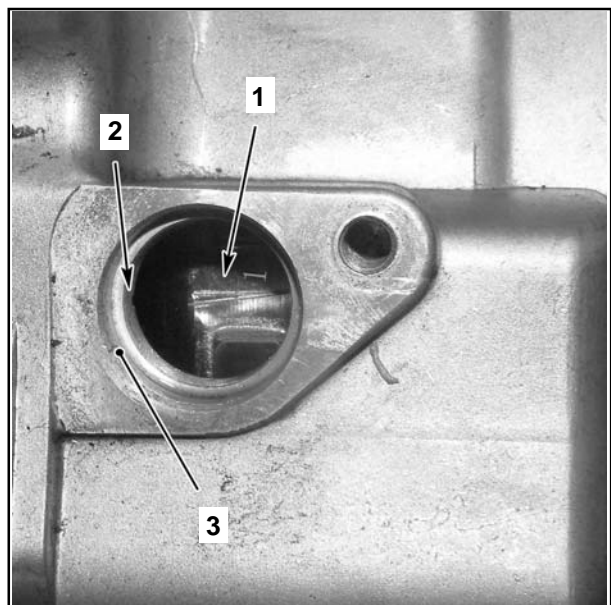

1. Mark "1" on MAG Flywheel

2. Notch on MAG Cover

3. CPS Location

NOTE: At TDC ignition, the printed marks on the camshaft timing gear have to be parallel to cylinder head base as per following illustration.

CAUTION: Crankshaft can not be locked at cylinder 1 TDC ignition.

Camshaft Removal

The removal procedure is the same for both camshafts. Each camshaft is different in design. Thus, it is important not to mix up any parts of the camshaft assembly with that of this other cylinder. Keep parts as a group.

Remove valve cover(see **VALVE COVER** above).

Remove chain tensioner(see **CHAIN TENSIONER** above).

Remove camshaft timing gear(see **CAMSHAFT TIMING GEAR** above).

Remove camshaft retaining plate.

Remove rocker arms(see **ROCKER ARM** above).

Remove camshaft.

NOTE: For removal, rotate camshaft so that intake/exhaust lobe shows to upper side of cylinder head.

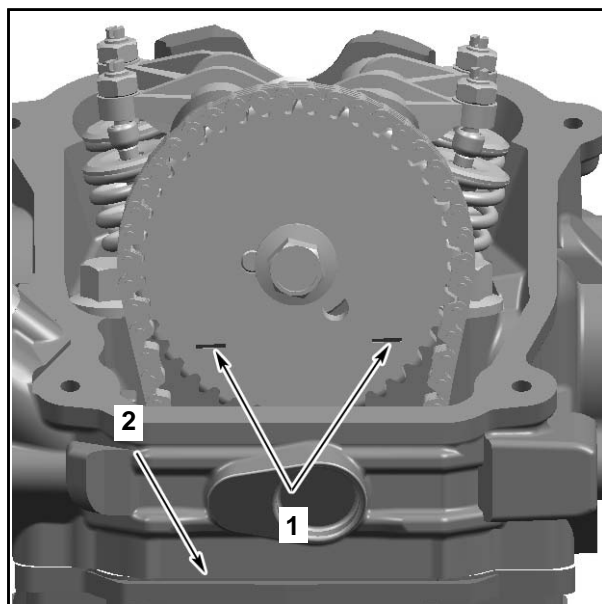

1.Marks on Camshaft Timing Gear
2.Cylinder Head Base

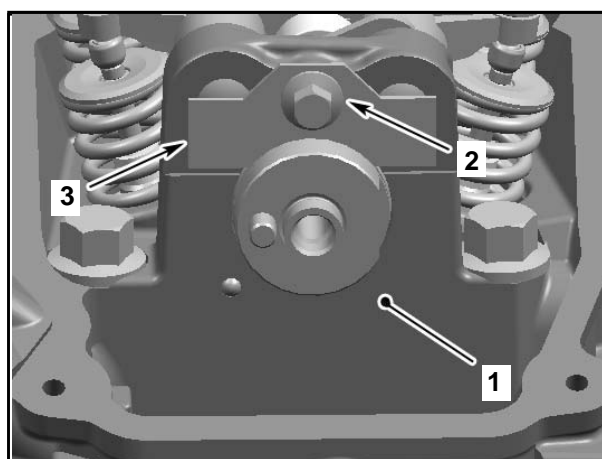

1.Cylinder Head
2.Screw
3.Camshaft Retaining Plate

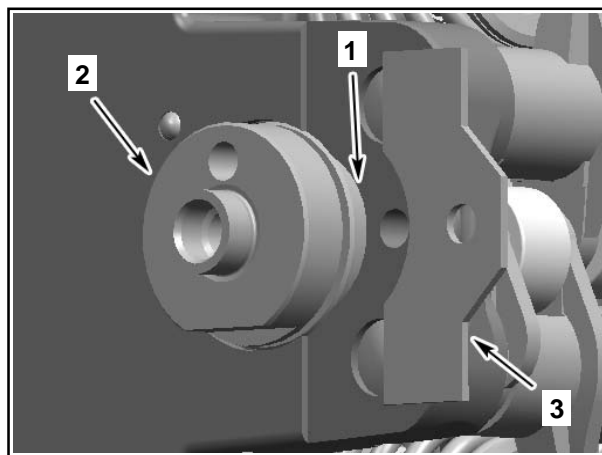

1.Area for Cranshaft Lobes
2.Camshaft
3.Camshaft Retaining Plate

Camshaft Inspection

Check each lobe and bearing journal of camshaft for scoring, scuffing, cracks or other signs of wear. Measure camshaft journal diameter and lobe height using a micrometer.

Camshaft Cylinder1	
Camshaft Lobe(exhaust)	
New	31.98-32.1mm (1.2591-1.2638in)
Service Limit	31.88mm(1.2551in)
Camshaft Lobe(Intake)	
New	32.129-32.249mm (1.2649-1.2696in)
Service Limit	32.03mm(1.2610in)

Camshaft Cylinder2	
Camshaft Lobe(exhaust)	
New	31.966-32.086mm (1.2585-1.2632in)
Service Limit	31.87mm(1.2547in)
Camshaft Lobe(Intake)	
New	32.163-32.283mm (1.2663-1.2710in)
Service Limit	32.06mm(1.2622in)

Camshaft Journal(Timing Chain Side)	
New	34.959-34.975mm (1.3763-1.3770in)
Service Limit	34.950mm(1.3760in)
Camshaft Journal(Spark Plug Side)	
New	21.959-21.980mm (0.8645-0.9654in)
Service Limit	21.950mm(0.8642in)

Measure matching clearance between two ends of camshaft and cylinder head.

Camshaft Bearing(Timing Chain Side)	
New	35.007-35.025mm (1.3782-1.3789in)
Service Limit	35.040mm(1.3795in)
Camshaft Bearing(Spark Plug Side)	
New	22.012-22.025mm (0.8666-0.8671in)
Service Limit	22.040mm(0.8677in)

Replace parts that are not within specifications.

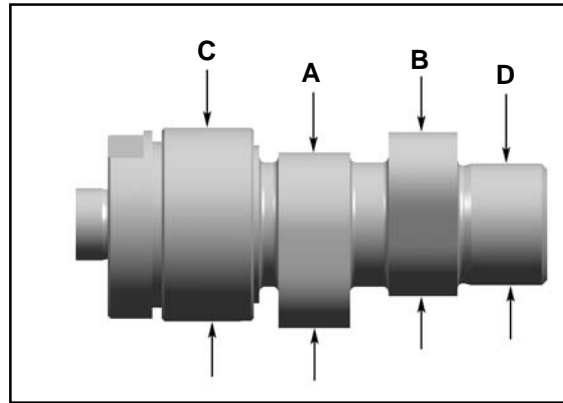

- A. Camshaft Lobe(Exhaust Valves)
- B. Camshaft Lobe(Intake Valves)
- C. Camshaft Journal(Timing Chain Side)
- D. Camshaft Journal(Spark Plug Side)

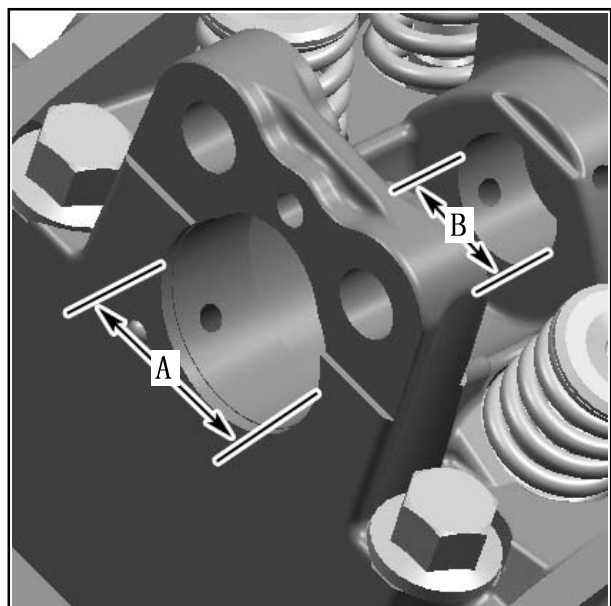

- A. Camshaft Bearing(Timing Chain Side)
- B. Camshaft Bearing(Spark Plug Side)

CAMSHAFT INSTALLATION

For installation, reverse the removal procedure. Pay attention to the following details.

CAUTION: The camshafts are not identical in design. Do not invert the camshafts during assembly. Any mis-up of the components will lead to engine damage.

Place the camshaft retaining plate in the slot of the camshaft.

For other parts, refer to proper installation procedure.

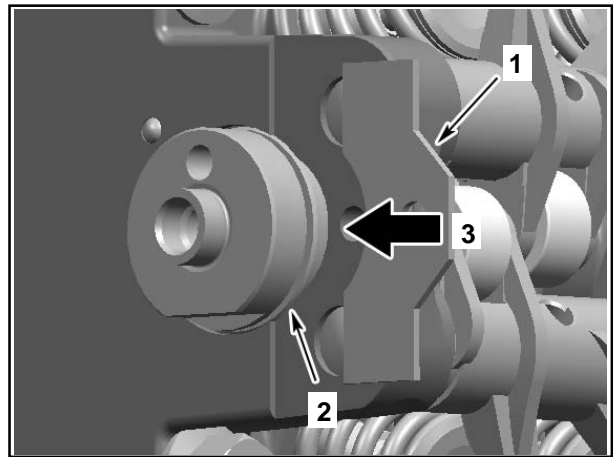

1. Camshaft Retaining Plate Position

2. Slot Retaining Shaft

3. Direction of Movement

VALVE SPRING

Valve Spring Removal

Remove rocker arm(see **ROCKER ARM** above). Remove cylinder head(see **CYLINDER HEAD** above).

Use valve spring compressor clamp(0180-022 006-922-001)to compress valve spring.

WARNING

Always wear safety glasses when disassembling valve springs. Be careful when unlocking valves. Components could fly away because of the strong spring preload.

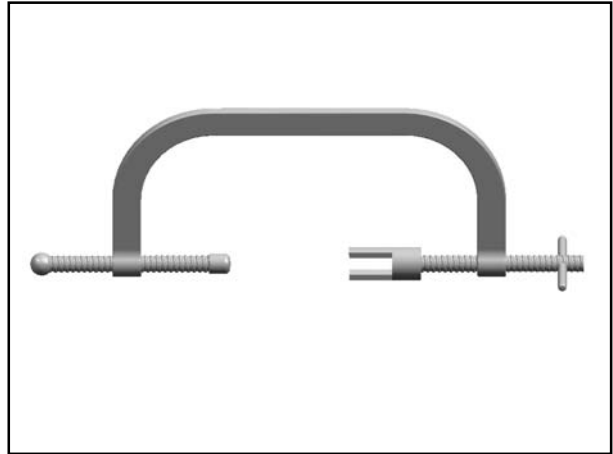

Valve Spring Compressor Clamp

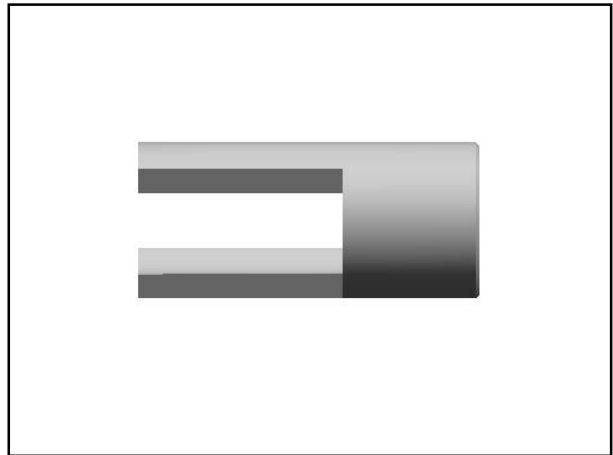

Valve Spring Compressor Cup

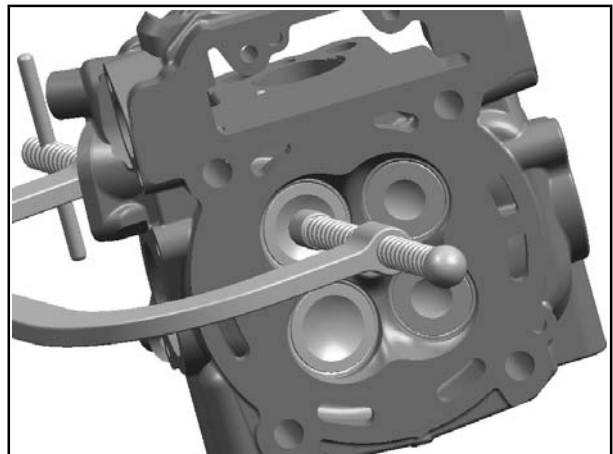

Align valve spring compressor clamp with the center of Valve

07 INTAKE MANIFOLD, CYLINDER HEAD AND CYLINDER

Remove valve cotters.

Withdraw valve spring compressor, valve spring retainer and valve spring.

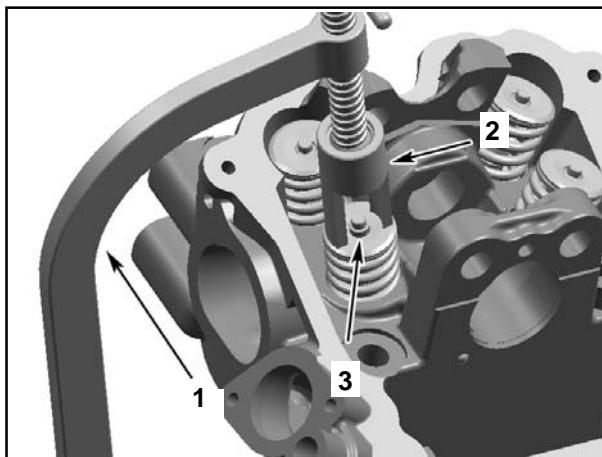

1. Valve Spring Compressor Clamp
2. Valve Spring Compressor Cup
3. Valve Cotter

Valve Spring Inspection

Check valve spring for visible damages, if any, replace valve spring.

Check valve spring for free length and straightness.

Valve Spring Free Length	
Normal New	40mm(1.575in)
Service Limit	38.2mm(1.504in)

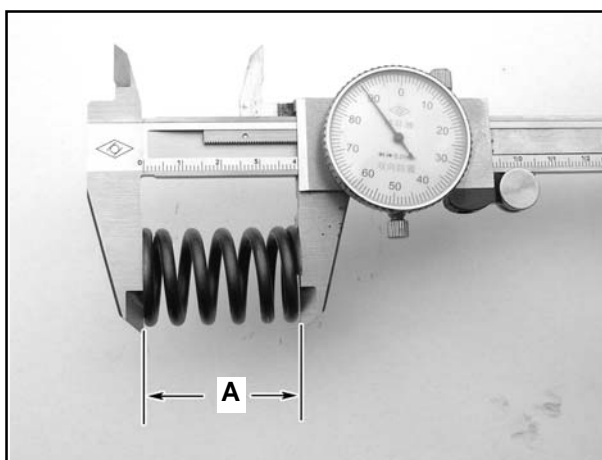

A. Valve Spring Length

Replace valves springs if not within specifications.

Valve Spring Installation

For installation, reverse the removal procedure. Pay attention to the following details.

Colored area of the valve spring must be placed on top.

To ease installation of cotters, apply oil or grease on them so that they remain in place while releasing the spring.

NOTE: Valve cotter must be properly engaged in valve stem grooves.

After spring is installed, ensure it is properly locked by tapping on valve stem end with a soft hammer so that valve opens and closes a few times.

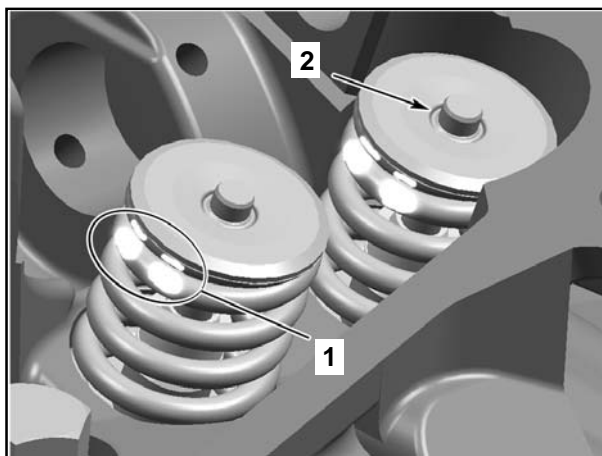

1. Position of the Valve Spring
2. Valve Cotter

CAUTION: An improper locked valve spring will cause engine damage.

VALVE

Valve Removal

Remove valve spring, see **VALVE SPRING** above.
Push valve stem, then pull valves(intake and exhaust)
out of valve guide.

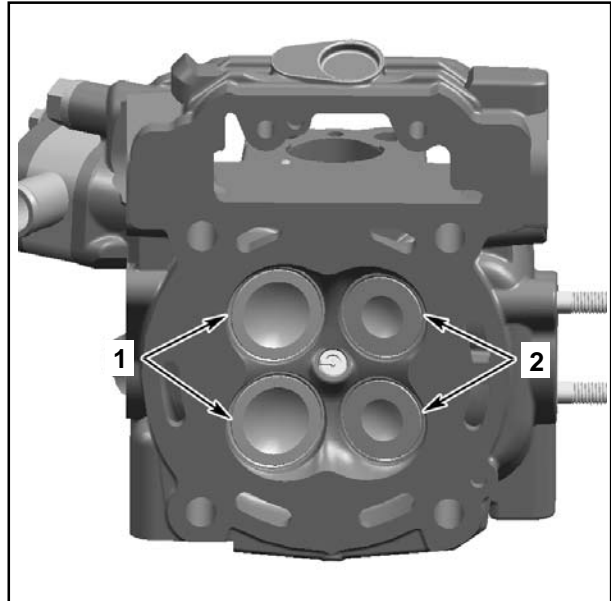

1.Intake Valve 33mm
2.Exhaust Valve 29mm

Remove valve stem seal with Snap-on pliers and dis-
card it.

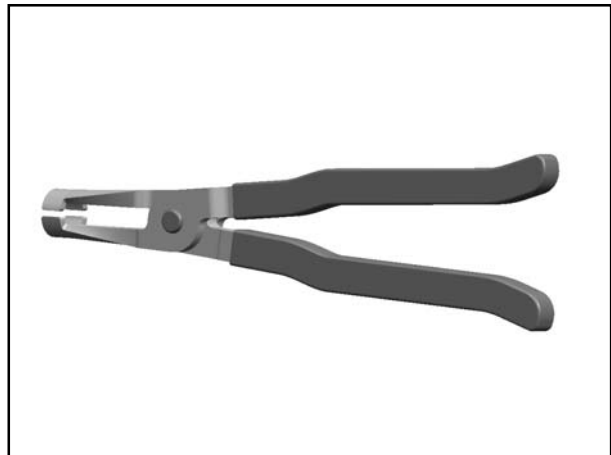

Plier

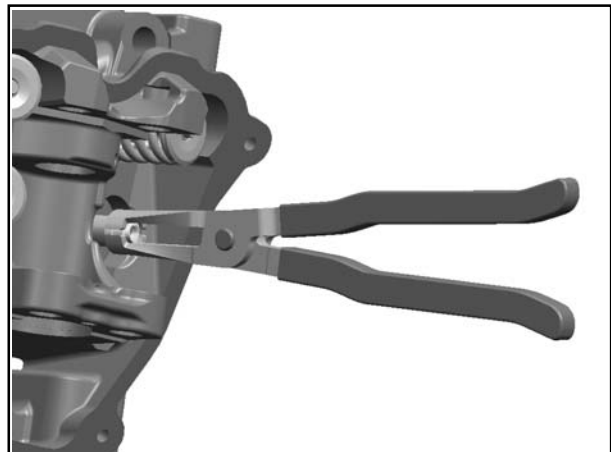

1.Plier
2.Valve Stem Seal

Valve Inspection

Valve Stem Seal

Always install new seals whenever valves are removed.

Valve

Inspect valve surface, check for abnormal stem wear and bending. If out of specification, replace by a new one.

Valve Out of Round (Intake and Exhaust Valves)	
New	0.005mm(0.0002in)
Service Limit	0.06mm(0.0024in)

Valve Stem and Valve Guide Clearance

Measure valve stem and valve guide in three places using a micrometer and a small bore gauge.

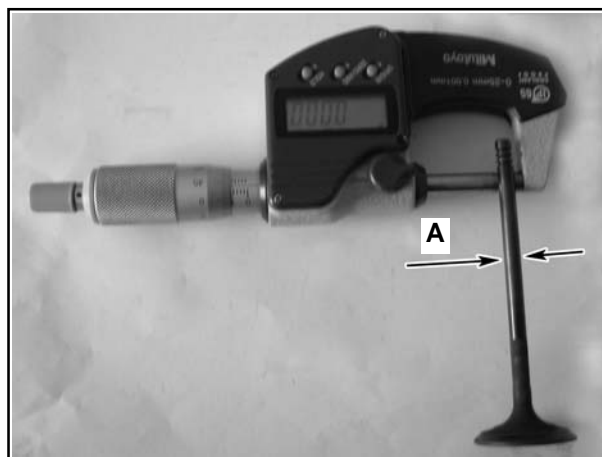

A. Valve Stem Diameter

NOTE: Clean valve guide to remove carbon deposit before measuring.

Change valve if valve stem is out of specification or has other damages such as wear or friction surface.

Valve Stem Diameter	
Exhaust Valve	
New	4.955-4.970mm (0.1951-0.1957in)
Service Limit	4.930mm(0.1941in)
Intake Valve	
New	4.965-4.980mm (0.1955-0.1960)
Service Limit	4.930mm(0.1941in)

Replace valve guide if valve guide is out of specification or has other damages, such as wear or friction surface.

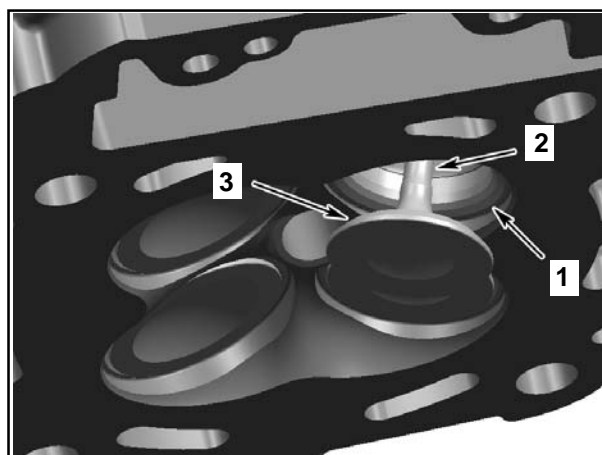

1. Valve Seat
2. Exhaust Valve Contaminated Area
3. Valve Face(Contact Surface to Valve Seat)

Valve Guide Diameter (Intake and Exhaust Valves)	
New	5.000-5.012mm (0.1969-0.1973in)
Service Limit	5.045mm(0.1986in)

Valve Face and Seat

Check valve face and seat for burning or pittings and replace valve or cylinder head if there are signs of damage.

Ensure to seat valves properly. Apply some lapping compound to valve face and work valve on its seat with a lapping tool(see **Valve Guide Procedure** below).

Measure valve face contact width.

NOTE: *The location of contact area should be in center of valve seat.*

Measure valve seat width using a caliper.

Valve Seat Contact Width	
Exhaust Valve	
New	1.20-1.40mm (0.047-0.055in)
Service Limit	1.80mm(0.071in)
Intake Valve	
New	1.10-1.30mm (0.043-0.051)
Service Limit	1.70mm(0.067in)

If valve seat contact width is too wide or has dark spots, replace the cylinder head.

Valve Installation

For installation, reverse the removal procedure. Pay attention to the following details.

Install a **NEW** valve stem seal. Make sure thrust washer is installed before installing seal.

Apply engine oil on valve stem and install it.

CAUTION: Be careful when valve stem is passed through sealing lips of valve stem seal.

To ease installation of cotters, apply oil or grease on them so that they remain in place while releasing the spring.

After spring is installed, ensure it is properly locked by tapping on valve stem end with a soft hammer so that valve opens and closes a few times.

CAUTION: An improper locked valve spring will cause engine damage.

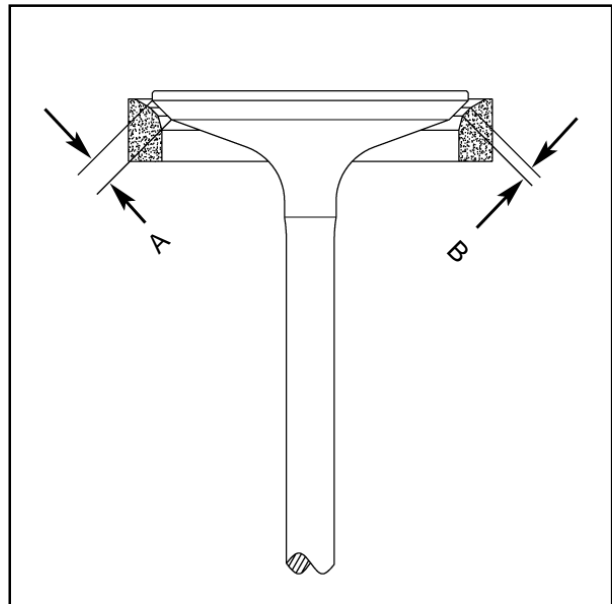

A. Valve Contact Surface Width

B. Valve Seat Contact Width

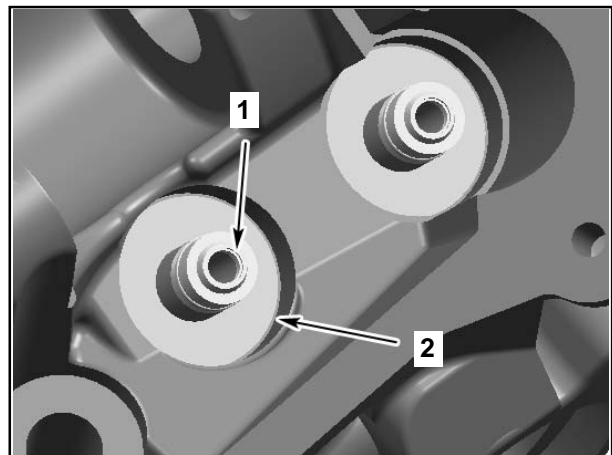

1. Valve Spring Lower Seat

2. Sealing Lips of Valve Stem Seal

VALVE GUIDE

Valve Guide Removal

Remove cylinder head(see **CYLINDER HEAD** above).
Remove valves(see **VALVE** above)

NOTE: Clean valve guide area from contamination before removal.

Use valve guide remover(0800-022102-922-001)and a hammer, drive the valve guide out of cylinder head.

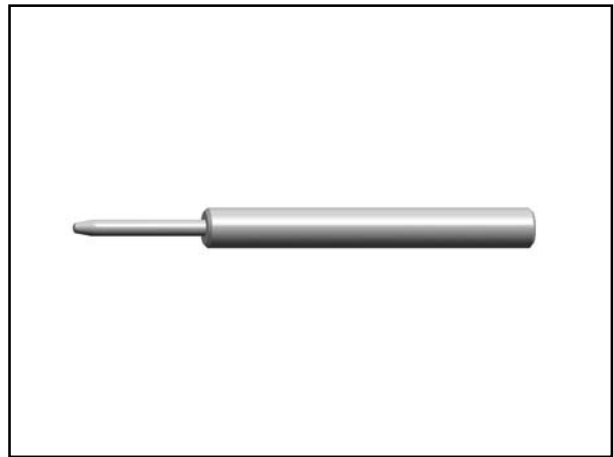

Valve Guide Remover

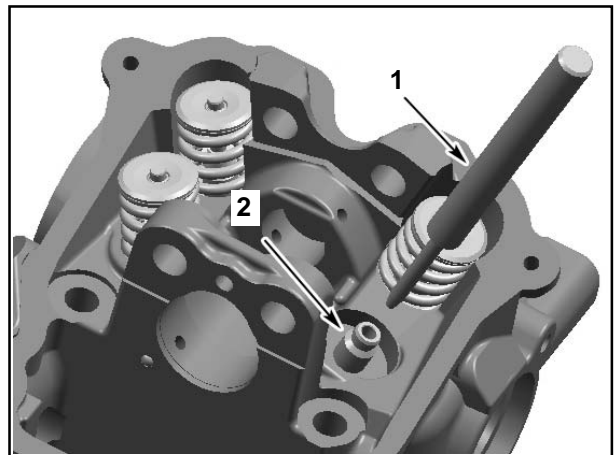

1. Valve Guide Remover
2. Valve Guide

Valve Guide Inspection

Always replace valve stem seals whenever valve guides are removed.

Clean the valve guide bore before reinstalling the valve guide into cylinder head.

Valve Guide Inspection

Reverse the removal procedure for installation. Pay attention to the following details.

Use valve guide installer(0800-022102-922-002)to install valve guide.

NOTE: Apply loctite(antiseize lubricant) on valve guide prior to install it into the cylinder head.

CAUTION: Push valve guide in the cold cylinder head as per following illustration.

Valve Guide (Measurement "A")	
New	14.70-15.30mm(0.5787-0.6024)

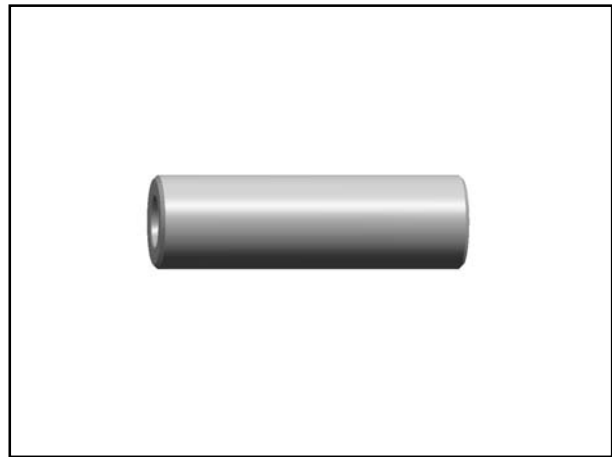

Valve Guide Installer

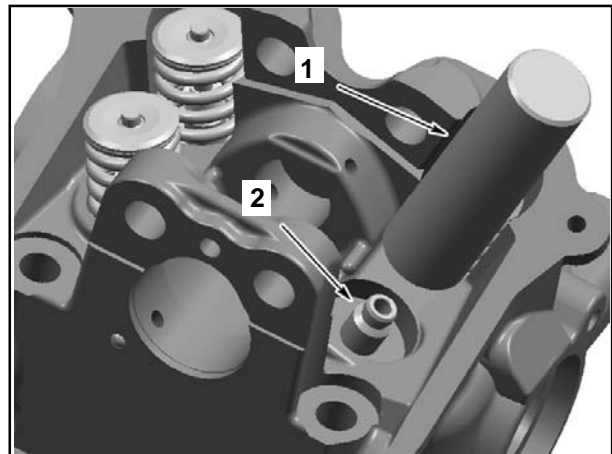

1. Valve Guide Installer
2. Valve Guide

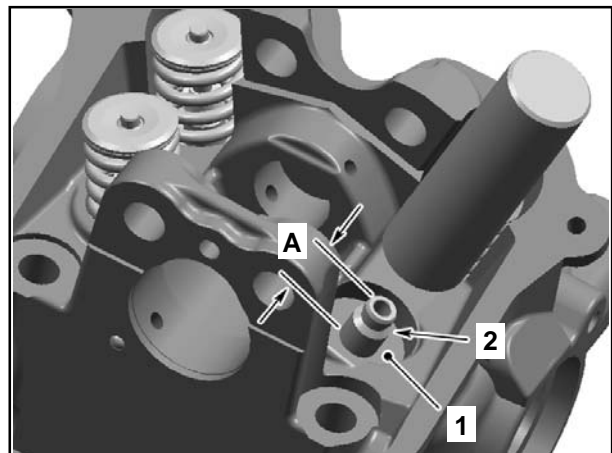

1. Thrust Surface of Cylinder Head
2. Valve Guide
A. Measurement from Thrust Surface to Valve Guide Top

07 INTAKE MANIFOLD, CYLINDER HEAD AND CYLINDER

Valve guide to be adjusted in diameter by using a reamer.

Valve Guide Diameter (Intake and Exhaust Valves)	
New	5.000-5.012mm(0.1969-0.1973in)

NOTE: Ensure to turn reamer in the right direction. Use cutting oil and make brakes to clean reamer/ valve guide from metal shavings.

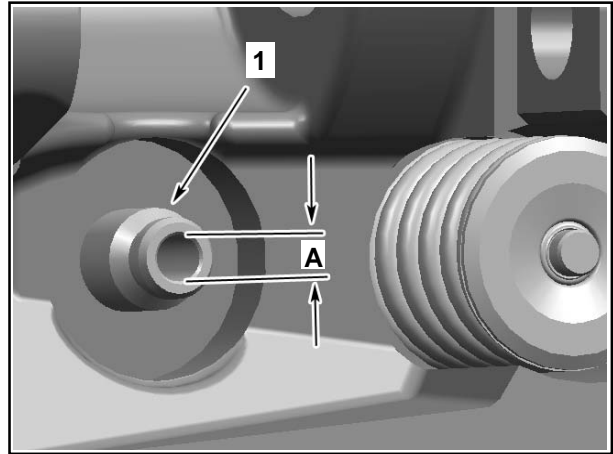

1. Valve Guide

A. Valve Guide Diameter

Apply some lapping compound to valve face and work valve on its seat with a lapping tool.

NOTE: Ensure to seat valves properly. Apply marking paste to ease checking contact pattern. Repeat procedure until valve seat/valve face fits together.

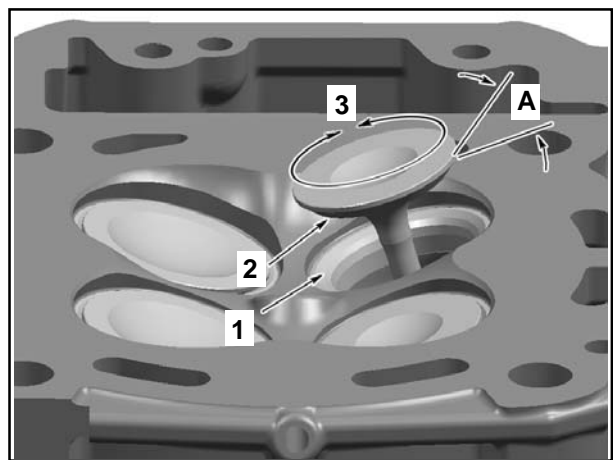

1. Valve Seat

2. Valve Face(contact surface to valve seat)

3. Turn valve while pushing against cylinder head

A. Valve Seat Angle 45°

CYLINDER

Cylinder Removal

Remove chain tensioner(see **CHAIN TENSIONER**).
Remove the camshaft timing gear(see **CAMSHAFT TIMING GEAR**).
Remove cylinder head(see **CYLINDER HEAD**).
Pull cylinder.
Discard cylinder base gaskets.

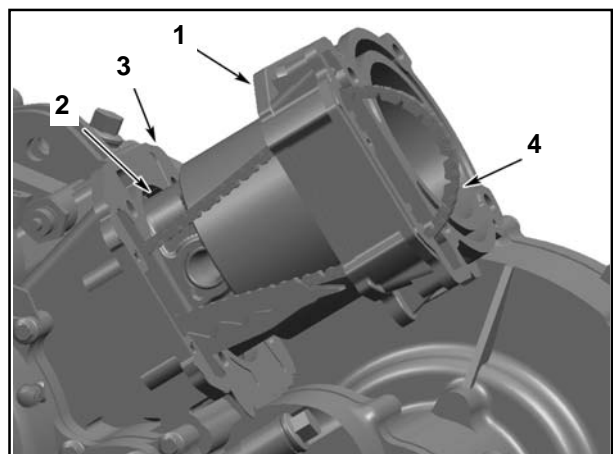

1. Cylinder

2. Piston Assembly

3. Cylinder Base Gasket

4. Camshaft Timing Chain

Cylinder Inspection

Check cylinder for cracks, scoring and wear ridges on the top and bottom of the cylinder. If so, replace cylinder.

Cylinder Taper

Measure cylinder bore and if it is out of specifications, replace cylinder and piston rings.

Measure cylinder bore at 3 recommended positions. See the following illustration.

Cylinder Taper IN Diameter (Intake and Exhaust Valves)	
New (maximum)	0.038mm(0.0015in)
Service Limit	0.090mm(0.0035in)

Distance between measurements should not exceed the service limit mentioned above.

Cylinder Out of Round

Measure cylinder diameter in piston axis direction from top of cylinder. Take another measurement 90° from first one and compare.

NOTE: Take the same measuring points like described in **Cylinder Taper** above.

Cylinder Out Of Round (Intake and Exhaust Valves)	
New (maximum)	0.015mm(0.0006in)
Service Limit	0.020mm(0.0008in)

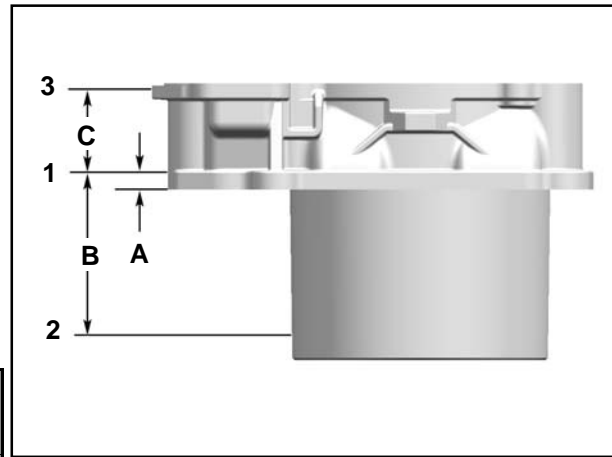

1. First Measuring of Diameter

2. Second Measuring of Diameter

3. Third Measuring of Diameter

A. 7mm(0.276 in) from Cylinder Bottom

B. 68mm(2.68 in)

C. 32mm(1.260 in)

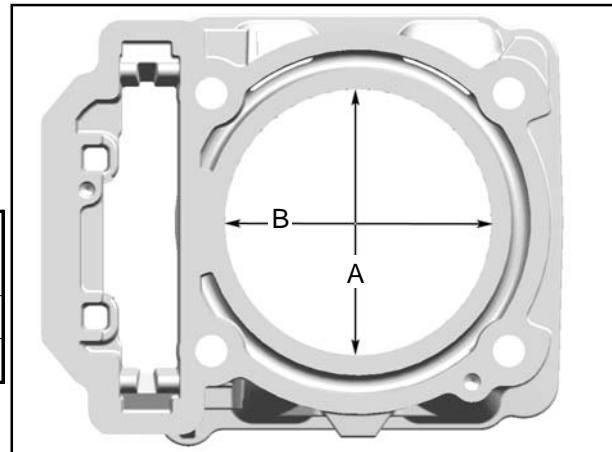

A. Perpendicular to Crankshaft Axis

B. Parallel to Crankshaft Axis

Cylinder Installation

Reverse removal procedure for installation. Pay attention to the following details.

CAUTION: Always replace cylinder base gasket before installing cylinder.

First mount cylinder 2. Then remove crankshaft locking bolt (P/N 529 035 617). Turn engine to piston 1 at TDC, mount cylinder 1. Cylinder can not be pushed fully over the piston unless the piston is located at TDC.

Apply engine oil in the bottom area of the cylinder bore and also on the brand of the piston ring compressor tool (0800-040003-922-001).

NOTE: Put timing chain through the chain pit then put the cylinder in place.

CAUTION: Chain guide has to be fixed between cylinder and cylinder head.

NOTE: After both cylinders are installed, turn crankshaft until piston of cylinder 2 is at TDC ignition and lock crankshaft. Refer to **CAMSHAFT**.

Install cylinder head and the other parts in accordance with the proper installation procedures.

PISTON

Piston Removal

Remove cylinder head (see **CYLINDER HEAD** above)

Remove cylinder (see **CYLINDER** above).

Place a rag under piston and in the area of timing chain compartment.

WARNING

Piston circlips are spring loaded.

Remove one piston circlip and discard it.

NOTE: Removal of both piston circlips is not necessary to remove piston pin.



Piston Ring Compressor Tool

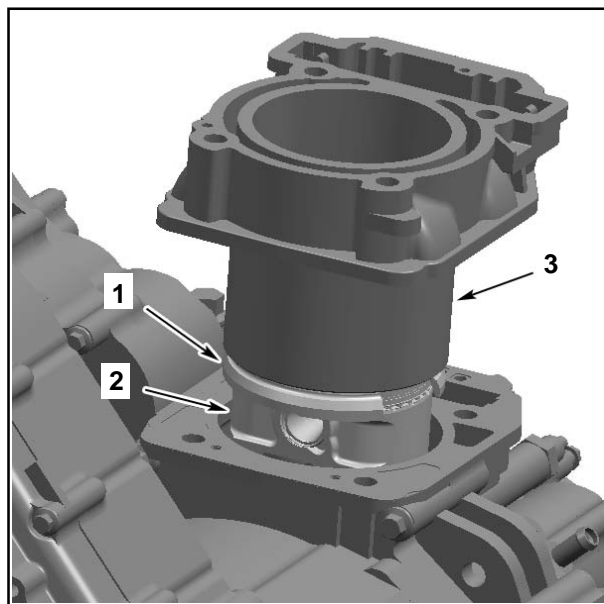

1. Piston Ring Compressor Tool

2. Piston

3. Cylinder

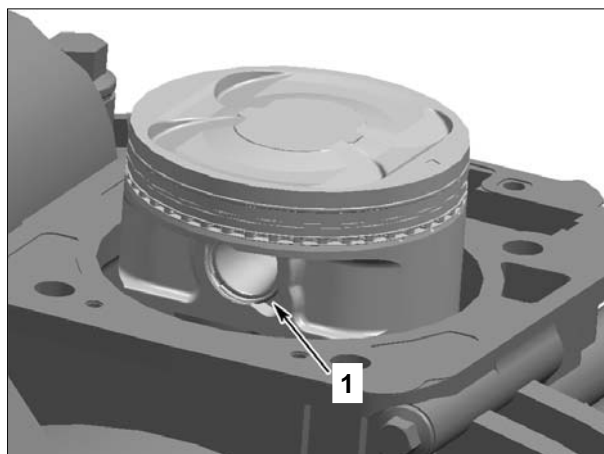

1. Piston Circlip

Push piston pin out of piston.

Detach piston from connecting rod.

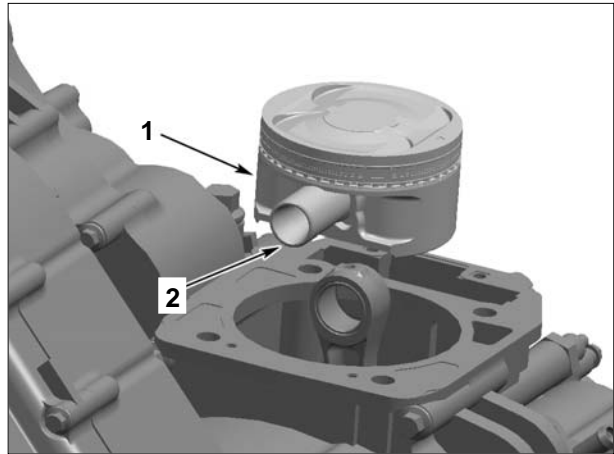

1.Piston

2.Piston Pin

Piston Inspection

Inspect piston for scoring, cracking or other damages.

Replace piston and piston rings if necessary.

Using a micrometer, measure piston at 8mm(0.315 in)perpendicularly(90°) to piston pin.

The measuring dimension should be as described in the following tables. If not, replace piston.

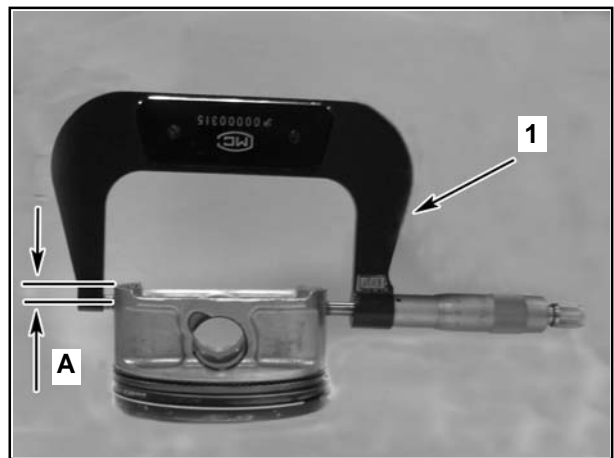

1.Measuring perpendicularly (90°) to piston pin

A.8 mm(0.315 in)

Piston Measurement	
New	90.950-90.970mm (3.5807-3.5815in)
Service Limit	90.85mm(3.577in)

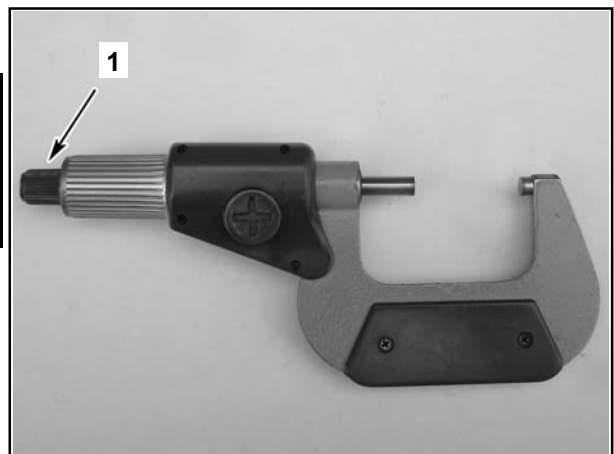

1.Micrometer set to the piston dimension

Piston/Cylinder Clearance

Adjust and lock micrometer to the piston dimension.

With the micrometer set to the dimension, adjust a cylinder bore gauge to the micrometer dimension and set the indicator to 0(zero).

Position the dial bore gauge 20mm(0.787 in) above cylinder base, measuring perpendicularly(90°) to piston pin axis.

Read the measurement on the cylinder bore gauge. The result is the exact piston/cylinder wall clearance.

Piston/Cylinder Clearance	
New	0.030-0.050mm (0.0012-0.0020in)
Service Limit	0.100mm(0.0040in)

NOTE: Make sure used piston is not worn.

if clearance exceeds specified tolerance, replace piston by a new one and measure piston/cylinder clearance again.

NOTE: Make sure the cylinder bore gauge indicator is set exactly at the same position as with the micrometer, otherwise the reading will be false.

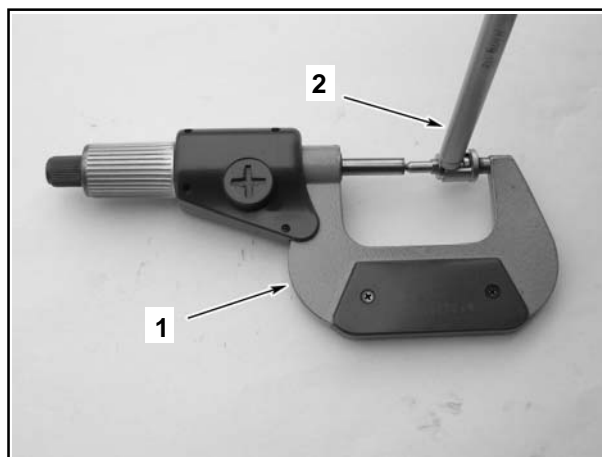

1. Use the micrometer to set the cylinder bore gauge
2. Dial Bore Gauge



1. Indicator set to 0(zero)

Connecting Rod/Piston Clearance

Using synthetic abrasive woven, clean piston pin from deposits.

Inspect piston pin for scoring, cracking or other damages.

Measuring piston pin. See the following illustration for the proper measurement positions.

Piston Pin Diameter	
New	21.995-22.000mm (0.8659-0.8661 in)
Service Limit	21.980mm(0.7866 in)

Replace piston pin if diameter is out of specifications.

Measure inside diameter of connecting rod small end bushing.

Connecting Rod Small End Diameter	
New	22.010-22.020mm (0.8665-0.8669 in)
Service Limit	22.060mm(0.8685 in)

Replace connecting rod if diameter of connecting rod small end is out of specifications. Refer to *BOTTOM END* for removal procedure.

Compare measurement to obtain teh connecting rodpiston clearance.

Connecting Rod/Piston Pin Clearance	
Service Limit	0.080mm(0.0035 in)

Piston Installation

Reverse the removal procedure for installation. Pay attention to the following details.

Apply engine oil on the piston pin.

Insert piston pin into piston and connecting rod.

CAUTION: Make sure the mounting direction of the piston is correct.

For each cylinder, install piston with the punched arrow on piston dome pointing toward the rear side of the engine.

Front Cylinder: Mark on top of piston must show to intake side.

Rear cylinder: Mark on top of piston must show to exhaust side.

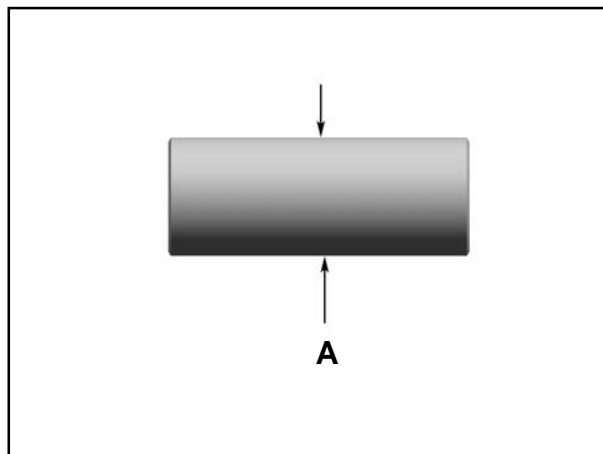

A.Piston Pin Diameter

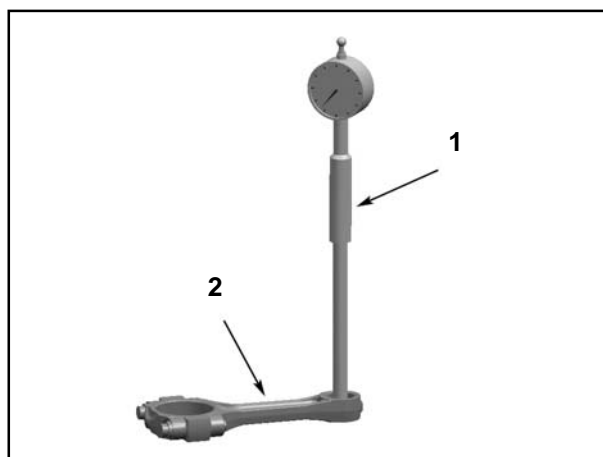

1.Bore Gauge
2.Connecting Rod

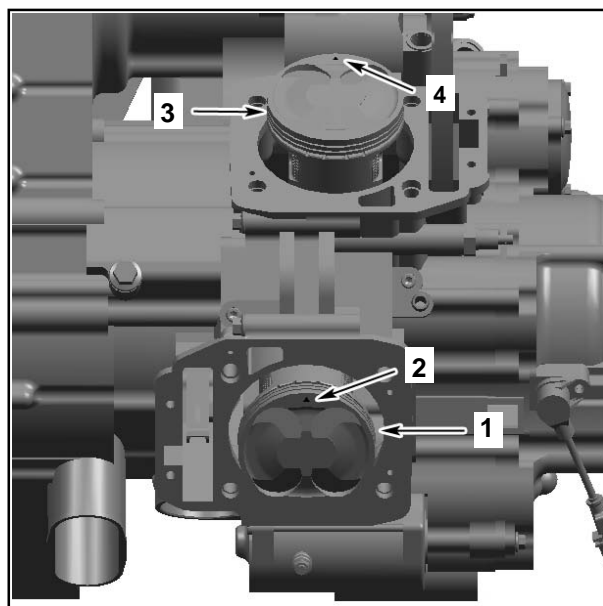

1.Piston of Cylinder 1
2.Mark on piston must show to exhaust side of cylinder 1
3.Piston of Cylinder 2
4.Mark on piston must show to exhaust side of cylinder 2

07 INTAKE MANIFOLD, CYLINDER HEAD AND CYLINDER

Use the piston appropriate circlip installer (0800-040005-922-001) to assemble the **NEW** piston circlip as per following procedure:

CAUTION: Always replace disassembled piston circlip(s) by new ones. Place a rag on cylinder base to avoid dropping the circlip inside the engine.

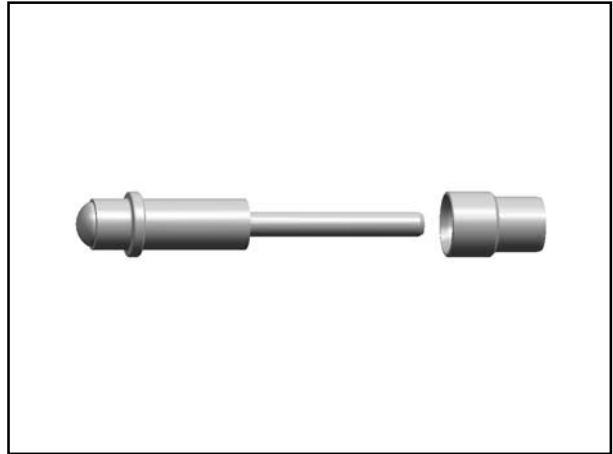

Circlip Installer

Place circlip in sleeve as per following illustration.

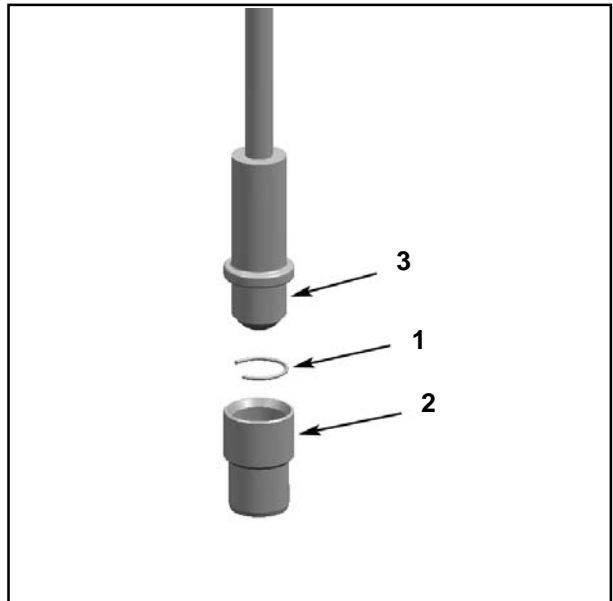

1. Piston Pin Circlip

2. Sleeve

3. Assembly Jig from Piston Clip Installer

Push taper side of assembly jig until circlip reaches middle of sleeve.

Align sleeve with piston pin axis and push assembly jig until engages in piston.

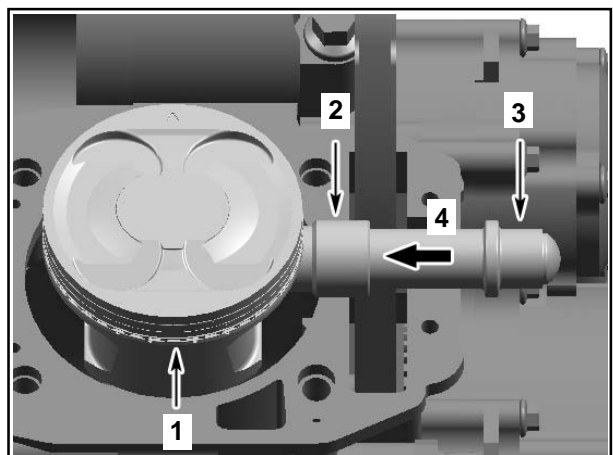

1. Hold piston while pushing circlip in place

2. Sleeve

3. Assembly Jig

4. Direction to push circlip

NOTE: Take care that the hook of the piston circlip is positioned properly.

Using a feeler gauge, check ring end gap. Replace ring if gap exceeds above described specified tolerance.

PISTON RINGS

Ring Removal

Remove the piston(see **PISTON** above).

Ring Inspection

Ring/Piston Groove Clearance

Using a feeler gauge measure each ring/piston groove clearance. If the clearance is too large, the piston and piston rings should be replaced.

Ring/Piston Groove Clearance	
Piston Ring(1)	
New	0.020-0.060mm (0.0008-0.0024in)
Service Limit	0.150mm(0.0059in)
Piston Ring(2)	
New	0.020-0.060mm (0.0008-0.0024in)
Service Limit	0.150mm(0.0059in)
Oil Scraper Ring	
New	0.030-0.150mm (0.0012-0.0059in)
Service Limit	0.250mm(0.0098in)

Ring End Cap	
Piston Ring(1)	
New	0.25-0.40mm (0.010-0.016in)
Service Limit	1.50mm(0.059in)
Piston Ring(2)	
New	0.30-0.45mm (0.012-0.018in)
Service Limit	1.50mm(0.059in)
Oil Scraper Ring	
New	0.20-0.70mm (0.008-0.028in)
Service Limit	1.50mm(0.059in)

To measure the ring end gap, place the ring in the cylinder in the area of 8–16mm(5/16–5/8in) from top of cylinder.

NOTE: In order to correctly position the ring in the cylinder, use piston as a pusher.



CORRECT POSITION OF THE PISTON CIRCLIP

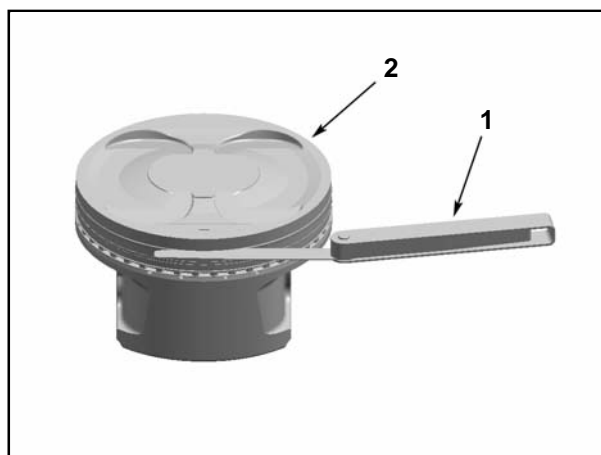

1. Feeler Gauge

2. Piston

07 INTAKE MANIFOLD, CYLINDER HEAD AND CYLINDER

Ring Installation

Reverse the removal procedure for installation.

NOTE: First install spring and then rings of oil scraper ring.

Install oil scraper ring first, then piston ring(2) with the word "N and TOP" facing up, then piston ring(1) with the word "N and TOP" facing up.

CAUTION: Ensure that top and second rings are not interchanged.

NOTE: Use a ring expander to prevent breakage during installation. The oil ring must be installed by hand.

Check that rings rotate smoothly after installation.

Space the piston ring end gaps 120° apart and do not align the gaps with the piston pin bore or the thrust side axis.

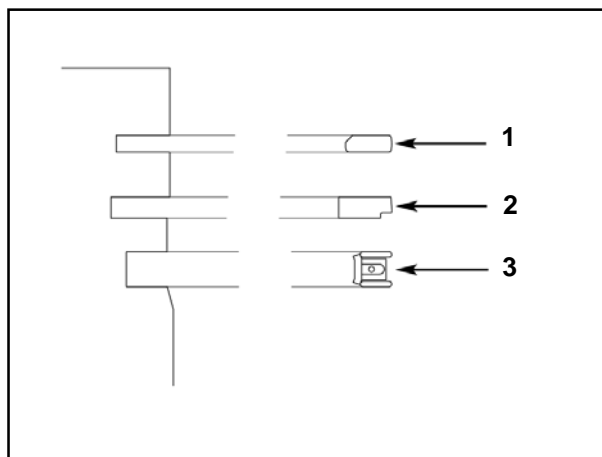

1. Upper Compression Ring

2. Lower Compression Ring

3. Oil Scraper Ring

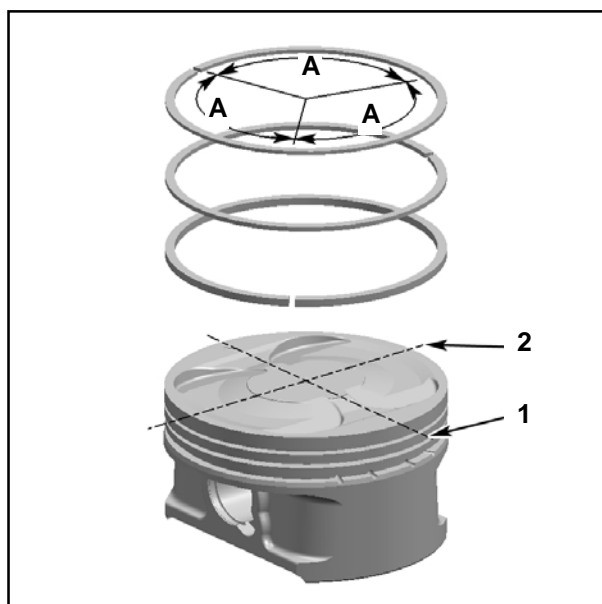

1. Don't align ring gap with piston thrust side axis

2. Don't align ring gap with piston pin bore axis

A. 120°

CRANKCASE, CRANKSHAFT, TRANSMISSION

SERVICE TOOLS

Description	P/N	Page
Breather Oil Seal Installer	0800-011201-923-001	06
Installation Jig, Breather Gear Shaft	0800-011201-921-003	06
Press Tool, Breather Gear Shaft	0800-011201-921-001	06
Left Crankcase Support Sleeve	0800-011101-922-001	09
Right Crankcase Support Sleeve	0800-012101-922-001	09
Plain Bearing Remover/Installer	0800-011102-922-001	09
Crankshaft Locking Bolt	0800-041000-922-001	14
Wrench, Front Output Shaft Circlip	0180-060008-922-001	18
Press Tool, Front Output Shaft Oil Seal	0800-060000-923-001	18
Installer, Front Output Shaft	0800-062301-923-001	18
Install Handle	0800-062206-922-001	20
Drive Pinion Gear Oil Seal Installer	0800-062204-923-001	20
Ring Gear Needle Bearing Installer	0180-062201-921-003	20
Drive Pinion Gear Needle Bearing Installer	0180-062103-921-002	20/21
Backlash Measurement Tool	0800-062000-922-001	21
Remover, Reverse Intermediate Gear Shaft	0800-060002-922-001	25
Remover, Left Crankcase Bearing	0800-011000-922-001	26
Remover, Right Crankcase Bearing 5206	0800-012000-922-001	26
Damper, Right Crankcase	0800-012101-921-001	32
Installer, Bearing 6203	0010-060002-921-002	32
Installer, Bearing 3206A	0180-012100-921-004	32
Damper, Left Crankcase	0800-011101-921-001	32
Press Tool, Reverse Intermediate Gear Shaft	0800-060000-922-001	32
Press Tool, Gearshift Shaft Bearing 6303	0180-011100-921-004	32
Press Tool, Bearing 6203	0040-012001-921-002	32

SERVICE PRODUCTS

Description	P/N	Page
Threadlocker		18
Engine coolant		35
Engine oil		

CRANKSHAFT

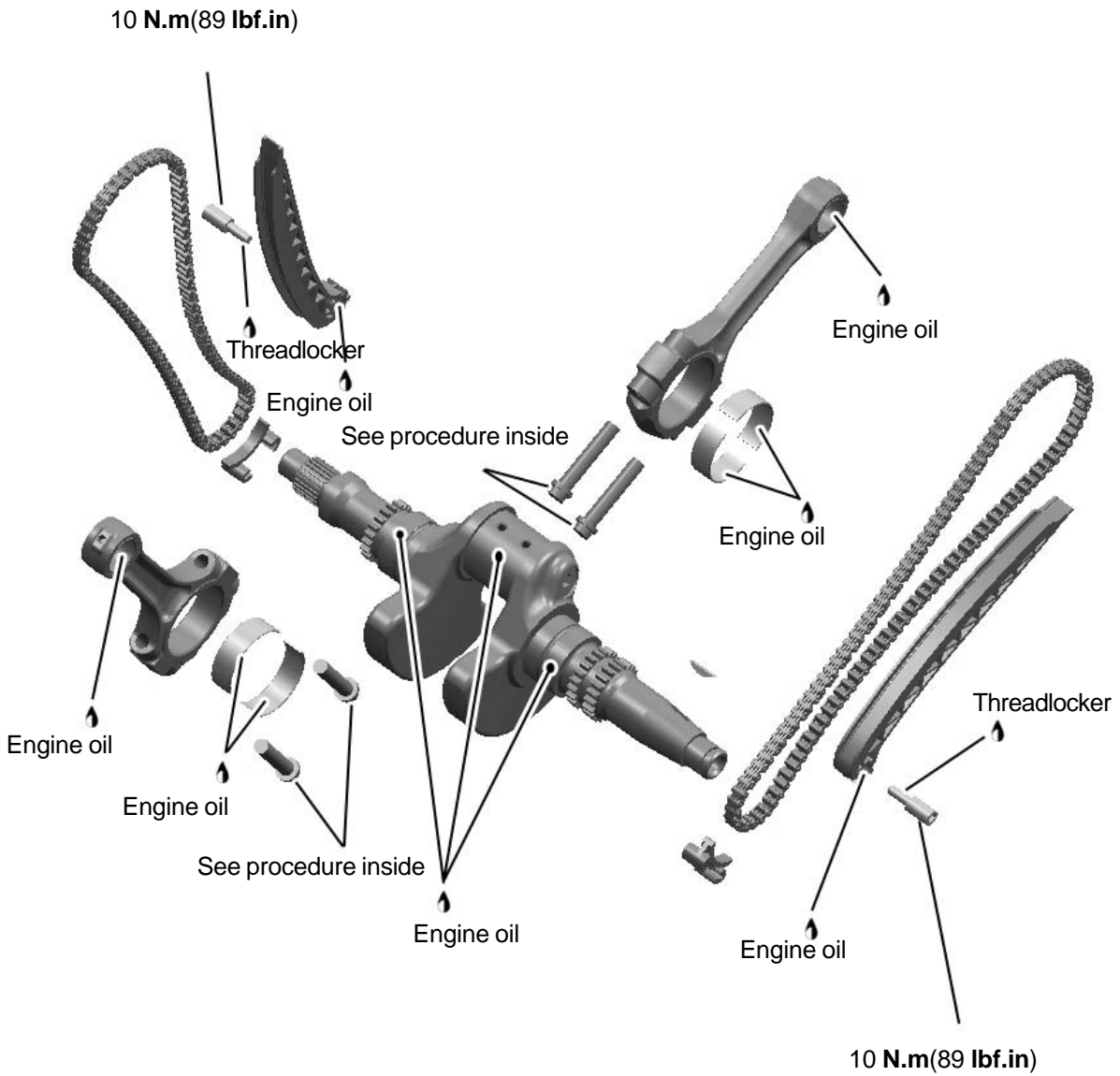

GEARBOX

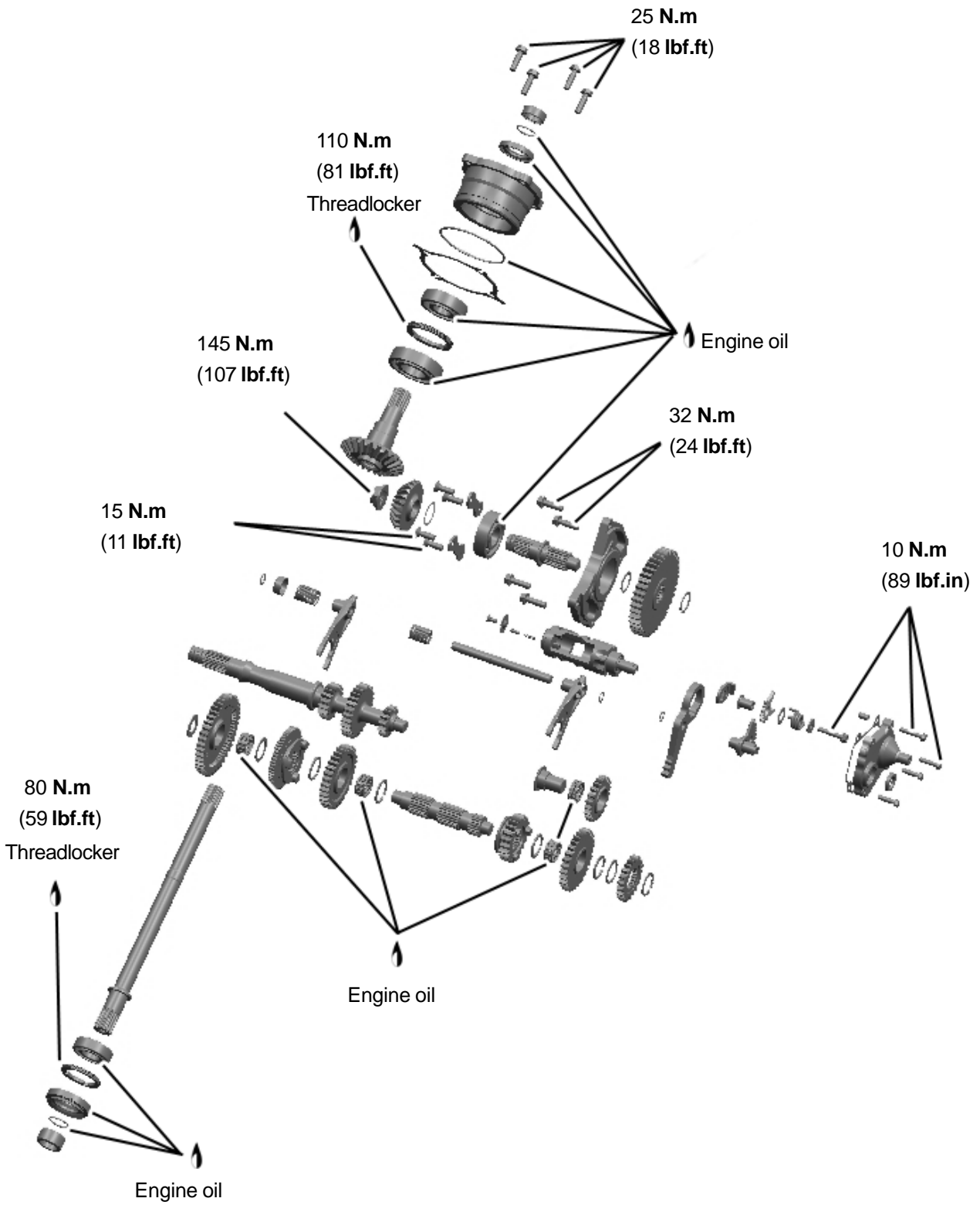

GENERAL

During assembly/installation,use the torque value and service products as shown in the exploded view(s).

WARNING

Torque Wrench Tightening specifications must strictly be adhered to .Locking devices (e.g.:locking tabs ,elastic stop nuts ,self-locking fasteners, cotter pin,etc.)must be replaced with new ones where specified .

NOTE:*Before disassembly ,drain engin oil and engine coolant.*

DRIVE GEARS

The drive gears are located on the MAG side behind the magneto cover.

Removal

Remove :

- Magneto cover(refer to **Magneto Cover Removal**, Chapter 11)
- Retainer ring no.10
- Magneto,driven gear
- Oil pump intermediate gear
- Breather intermediate gear
- Oil pump gear (refer to **LUBRICATION SYSTEM**)
- water pump gear
- Breather gear

Inspection

Oil Pump Intermediate Gear/Breather Intermediate Gear/Oil Pump Gear

Inspect gears for wear or damage,replace if damaged.

Breather Gear

The engine is equipped with a breather gear which prevents engine oil coming out though the breathing system into the air box.

Inspect gear for wear or damage .

Check ball bearing for excessive play and smooth operation .Replace breather gear assembly if necessary

Installation

The installation essentially the reverse of the removal procedure ,but pay attention to the follow details:

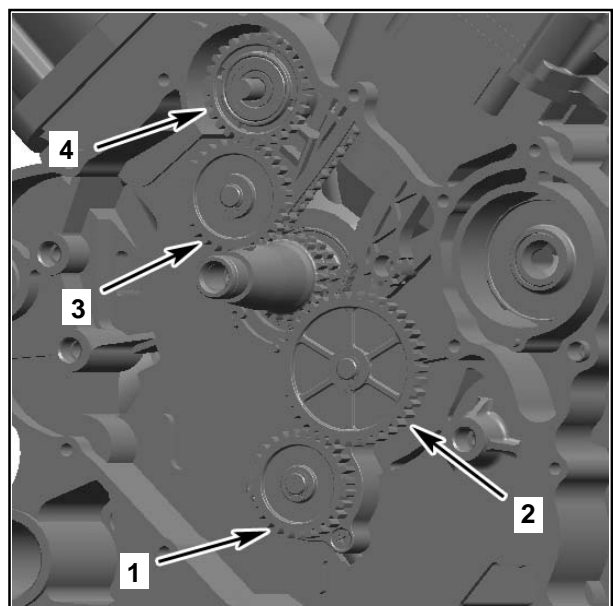

- 1.Oil Pump Gear
- 2.Oil Pump Intermediate Gear
- 3.Breather Intermediate Gear
- 4.Breather Gear

1. Replace the oil seal of the breather gear.
2. Adequately oil the ball bearing of the breather gear.
3. All drive gears on the same plane.
4. Replace the retainer ring no. 10.

Service Tools:

Breather Oil Seal Installer
0800-011201-923-001
Installation Jig, Breather Gear Shaft
0800-011201-921-003
Press Tool, Breather Gear Shaft
0800-011201-921-001

TIMING CHAIN

The engine is equipped with two chains. One is located on the magneto side. The second is located on the CVT side.

Removal(MAG side)

Remove:

- valve cover chain tensioner, camshaft timing gear (refer to **INTAKE MANIFOLD, CYLINDER HEAD AND CYLINDER**)
- Magneto, driven gear, oil pump intermediate gear, breather intermediate gear.
- Timing chain guide and lower timing chain guide.

Carefully pull the timing chain sideward and down from the crankcase.

NOTE: Mark the operation direction of the timing chain before removal.

Removal(CVT side)

Remove:

- valve cover chain tensioner and camshaft timing gear (refer to **INTAKE MANIFOLD, CYLINDER HEAD AND CYLINDER**)
- CVT cover CVT drive gear CVT driven gear £→ Belt
Note Mark operation direction of the belt .
- CVT case Clutch

-Timing chain guide and lower timing chain guide.
Carefully pull the timing chain sideward and down from the crankcase.

Note: Mark the operation direction of the timing chain before removal.

Inspection

Inspection is the same for both timing chains. Check timing chain on camshaft timing gear for excessive radial play. Check chain condition for wear and teeth condition. If chain is excessively worn or damaged, replace it as a set (camshaft timing gear and timing chain)

Installation

Installation is the same for both timing chains.

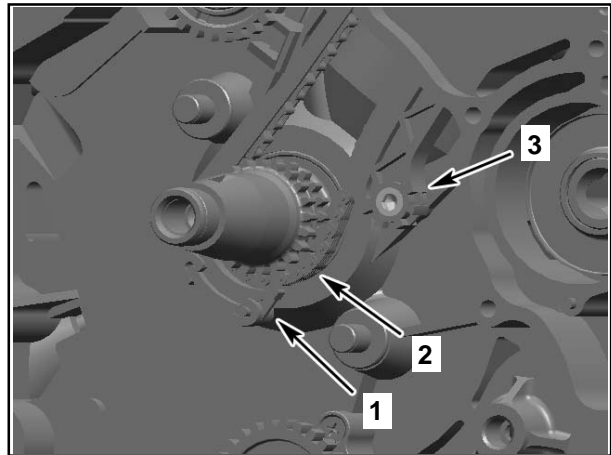

1. Timing Chain Guide
2. Timing Chain
3. Chain Tensioner

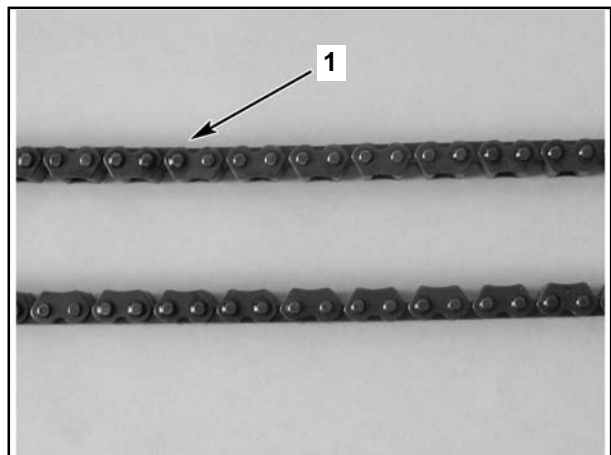

1. Timing Chain

The installation essentially the reverse of the remove procedure ,but pay attention to the follow details:

Note:Ensure to perform proper valve timing .lock crankshaft (see crankshaft)and camshaft at TDC ignition (refer to intake manifold ,cylinder head and cylinder section).Install timing chain with camshaft timing gear then ,adjust chain tension (refer to intake manifold , cylinder head and cylinder section).Loosen crankshaft ,turn 440 degree on clockwise direction (from CVT side) and camshaft at TDC ignition,Install timing chain with camshaft timing gear then ,adjust chain tension,to perform proper valve timing(refer to intake manifold , cylinder head and cylinder section).

CAUTION:Improper valve timing will damage engine components.

TIMING CHAIN TENSIONER

Removal

Refer to **TIMING CHAIN** above.

Inspection

Check timing chain tensioner for wear ,cracks or other damage ,replace if necessary.

Installation

The installaiton is the reverse of the removal procedure .

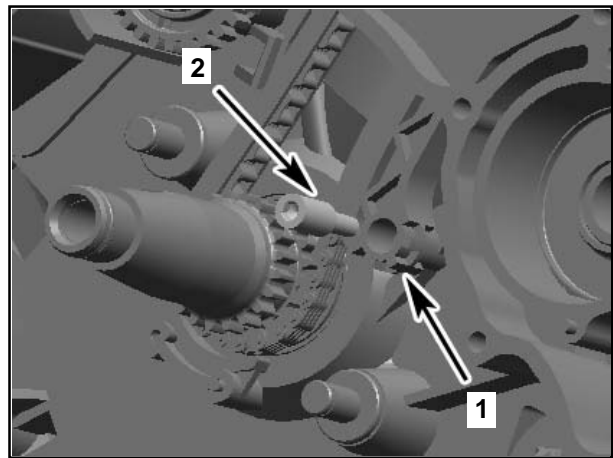

1.Chain Tensioner
2.Screw

CRANKCASE

NOTE:Before disassembly ,drain engin oil and engine coolant.

Crankcase Disassembly

NOTE:Before splitting the crankcase,measure crankshaft axial play (refer to **CRANKSHAFT**).

Remove:

- Front drive shaft,ring gear
- CVT cover,CVT,belt,CVT air guide and clutch(refer to **CVT AND CLUTCH**)
- Drive gears(refer to **DRIVE GEARS**)

NOTE:Oil pump removal from crankcase is not necessary ,but recommended to see condition of oil pump.

- Left crankcase cover and electric starter(refer to **MAGNETO SYSTEM**)
- electric starter drive gear(refer to **STARTING SYSTEM**)
- oil filter(refer to **LUBRICATION SYSTEM**)

-Cylinder head and cylinder(refer to **INTAKE MANIFOLD,CYLINDER HEAD AND CYLINDER**)

-Timing chain,tensioner and guide.(refer to **TIMING CHAIN,TENSIONER AND GUIDE**).

Remove all bolts of crankcase.

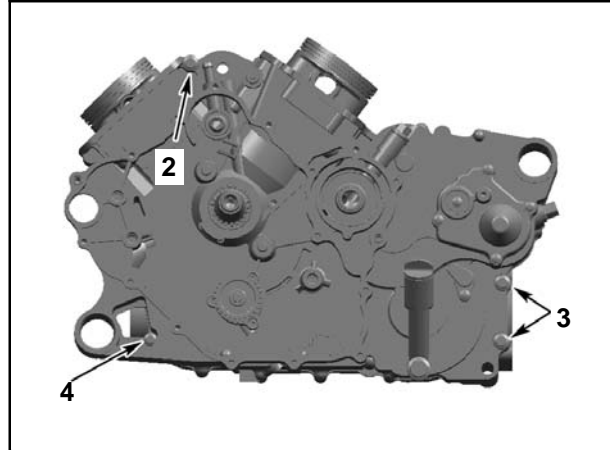
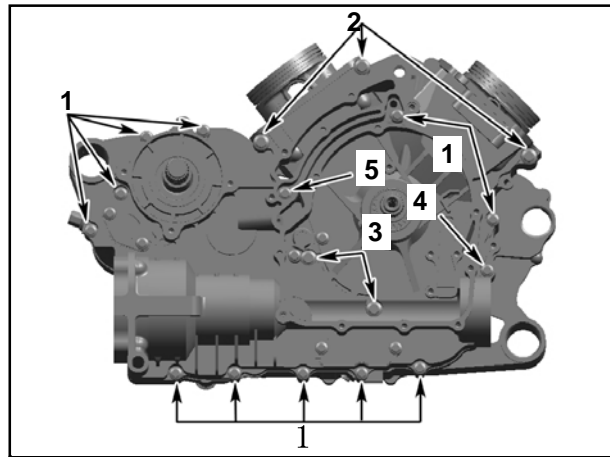

- 1.11 bolt M6X45
- 2.4 bolt M8X60
- 3.4 bolt M8X50
- 4.2 bolt M6X50
- 5.1 bolt M6X80

Carefully split crankcase halves by using a soft hammer .

NOTE:*During disassembly ,do not damage the sealing surface of the crankcase halves.*

Pull crankshaft out of crankcase.

Crankcase Cleaning

WARNING
Use safety goggles to avoid eye injuries.

Clean crankcase using a part cleaner;
Dry crankcase using compressed air;
Clean oil passage.

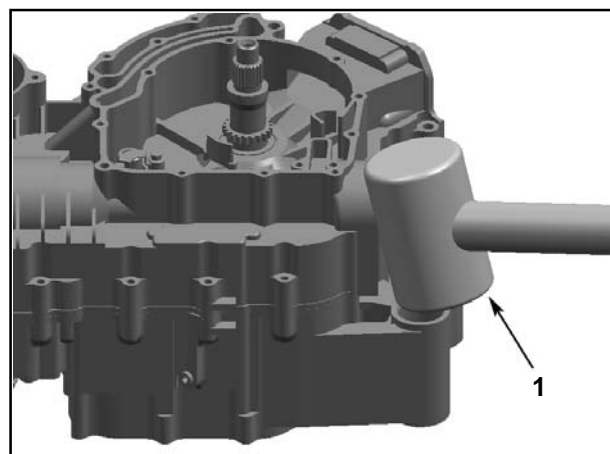

- 1.Soft Hammer

Crankcase inspection

Check crankcase halves for cracks or other damage. replace if necessary.

Check plain bearing for scoring or other damages.

NOTE: Measure plain bearing inside diameter and compare to magneto and CVT side journal diameter of crankshaft (refer to **CRANKSHAFT**). Replace if the measurements are out of specification.

plain bearing inside diameter (CVT/MAG)

service Limit: 42.100mm (1.6575in)

Plain Bearing Replacement

plain bearing removal

Caution: Always support crankcase halves properly when ball bearings or plain bearings are removed. Damages to crankcase halves may occur if this procedure is not performed correctly.

NOTE: Always use a press for removal of plain bearing. Remove plain bearing with the proper plain bearing remove/installer.

Carefully push the plain bearings out from the crankcase half inside towards the outside.

NOTE: Place the proper crankcase support sleeve under crankcase halves before removing plain bearings.

NOTE: During disassembly, do not damage the sealing surface of the crankcase halves.

Service Tools:

Left crankcase support sleeve

0800-011101-922-001

Right crankcase support sleeve

0800-012101-922-001

Plain bearing remover/installer

0800-011102-922-001

Plain Bearing Installation

NOTE: Crankcase and plain bearing must be installed as a pair as shown in the following table:

Crankcase	Plain Bearing
Red (A)	Red
Blue (B)	Blue

CAUTION: Unless otherwise instructed, never use hammer to install ball bearings or plain bearings, use press only.

Install plain bearings with the proper plain bearing remover/installer in a cool crankcase. Do not lubricate plain bearing and /or crankcase for installation.

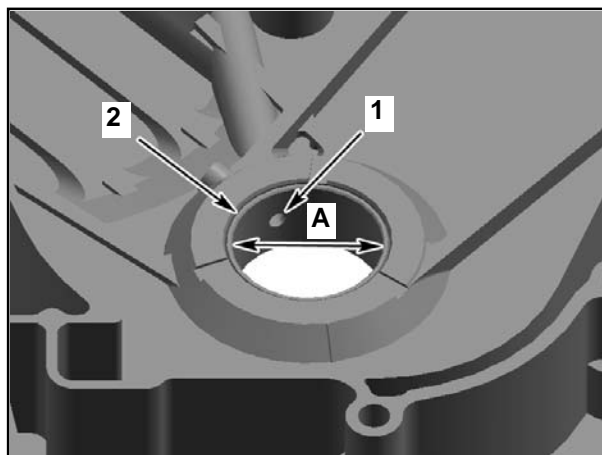

1. Oil bore
2. Plain bearing
3. Measure plain bearing inside diameter

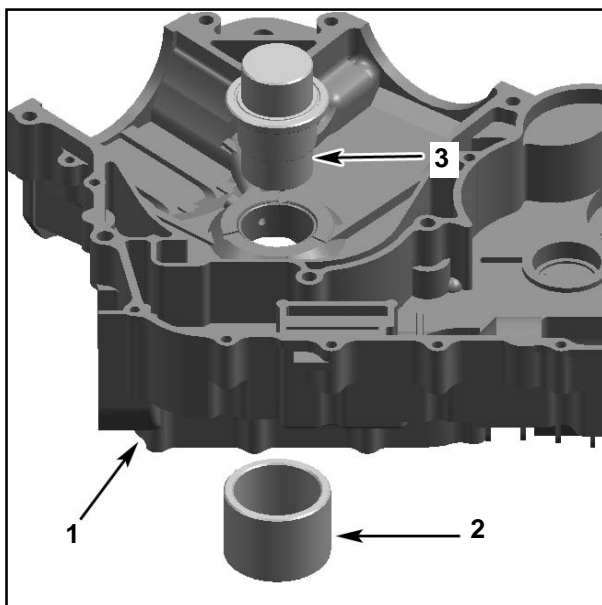

1. Crankcase half
2. Crankcase support sleeve
3. Plain bearing remover/installer

NOTE: Place proper crankcase support sleeve under the crankcase halves before installing the plain bearings (refer to bearing removal procedure).

Carefully press-in the plain bearings in the same direction as during disassembly, from then crankcase inside towards the outside.

During disassembly, make sure not to damage the sealing surface of the crankcase halves.

CAUTION: Mark position of oil bore on crankcase half and on plain bearing remover/installer. Align mark on plain bearing remover/installer with mark on crankcase half.

NOTE: Wrong oil bore will stop supply to plain bearing and will cause engine damaged.

CAUTION: The partition of the plain bearing in left crankcase must be positioned near to oil bore in clockwise direction. (refer to No.2 in next installation)

CAUTION: The partition of the plain bearing in right crankcase must be positioned near to oil bore in clockwise direction. (refer to No.2 in next installation)

NOTE: Use an o-ring ($\phi 42 \times 1-1.5 \text{mm}$ (0.04-0.05in)) to hold plain bearing in place during installation, the o-ring will disappear in the groove of the plain bearing remover/installer.

Service Tools:

Left crankcase support sleeve

0800-011101-922-001

Right crankcase support sleeve

0800-012101-922-001

Plain bearing remover/installer

0800-011102-922-001

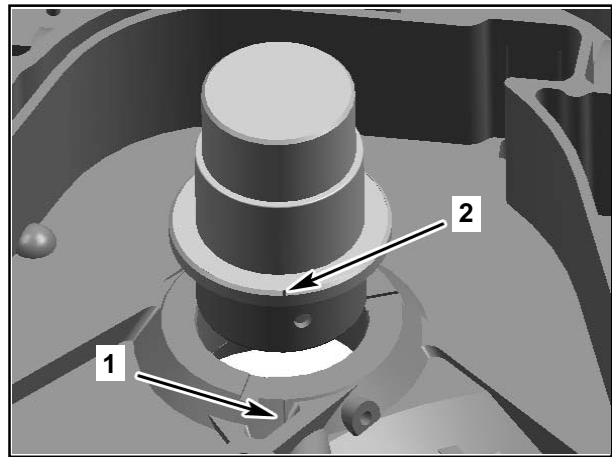

1. Oil position marked on crankcase
2. Plain bearing remover/installer

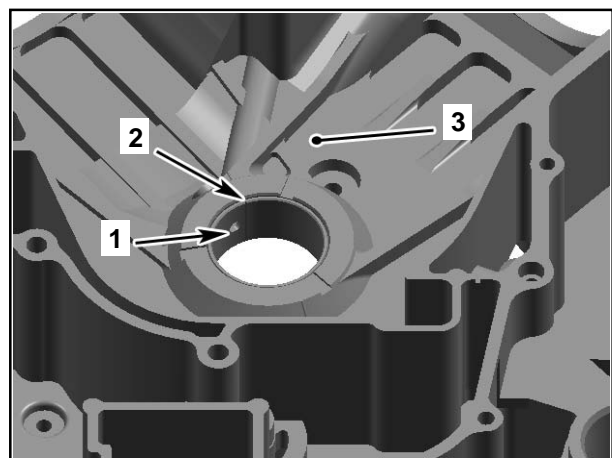

1. Oil bore
2. The partition of the plain bearing
3. Left crankcase

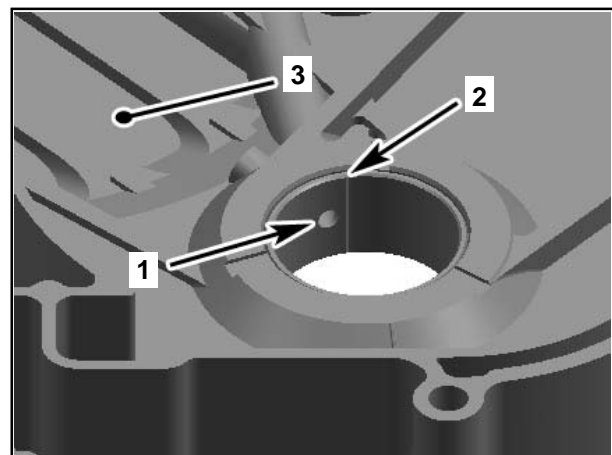

1. Oil bore
2. The partition of the plain bearing
3. Right crankcase

Crankcase Assembly

The assembly procedure of crankcase is the reverse of disassembly procedure. However, pay attention to the following details.

1. Clean oil passages and make sure they are not clogged.
2. Clean all metal components.
3. Carefully clean contact surface between left and right crankcase.
4. Install a new crankcase gasket.
5. Apply engine oil when install crankshaft bearing.

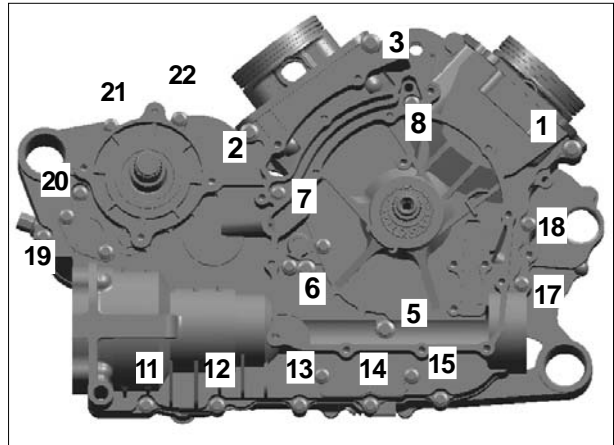

ATTENTION: Correctly reinstall crankshaft (refer to CRANKSHAFT).

Tighten screws on crankcase in sequence as shown in right picture.

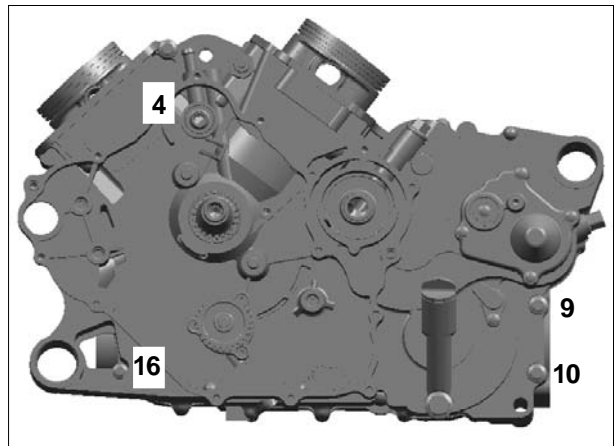

CRANKSHAFT

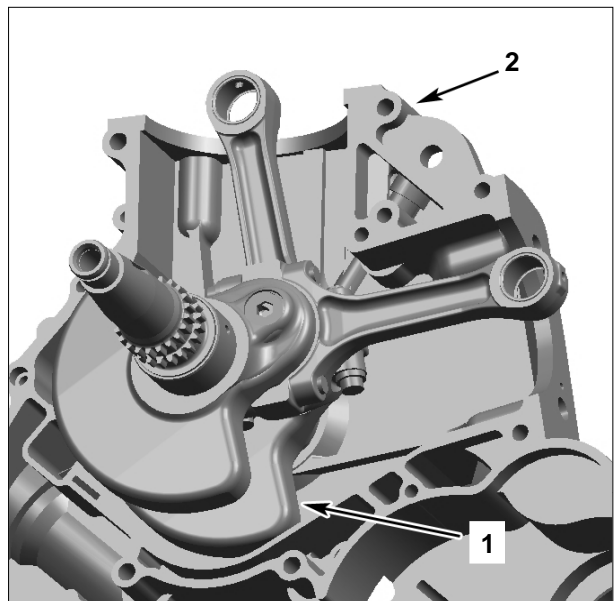

1. Crankshaft
2. Right Crankcase

Crankshaft Locking Procedure

NOTE: When crankshaft is locked, rear cylinder (cylinder No.2) is at TDC ignition, crankshaft cannot locked at TDC of front cylinder (Cylinder No. 1)

Remove:

- Spark plug cable and spark plugs of both cylinders
- Valve covers of both cylinders
- Plug cover and gasket of plug cover

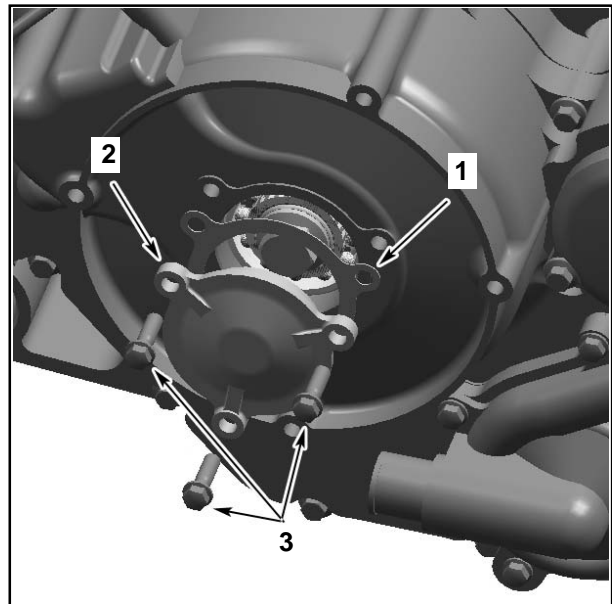

1. Gasket
2. Plug Cover
3. Screws

- Crankshaft position sensor(CPS)

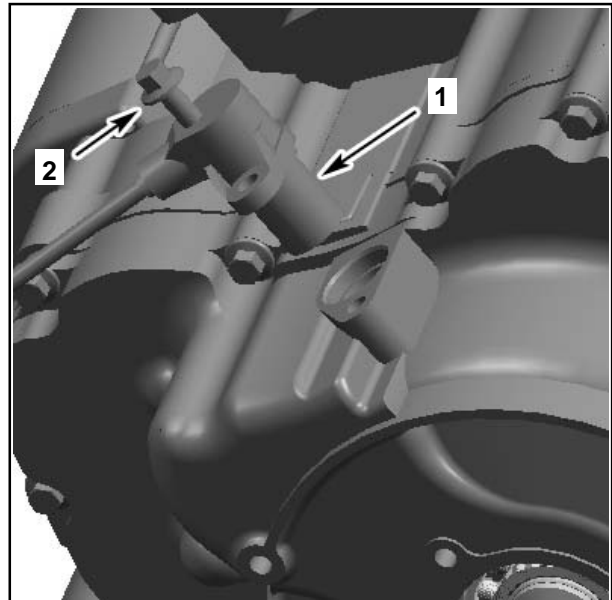

1. Crankshaft position sensor
2. Screw

08 CRANKCASE, CRANKSHAFT, GEARBOX

-Screw and gasket washer

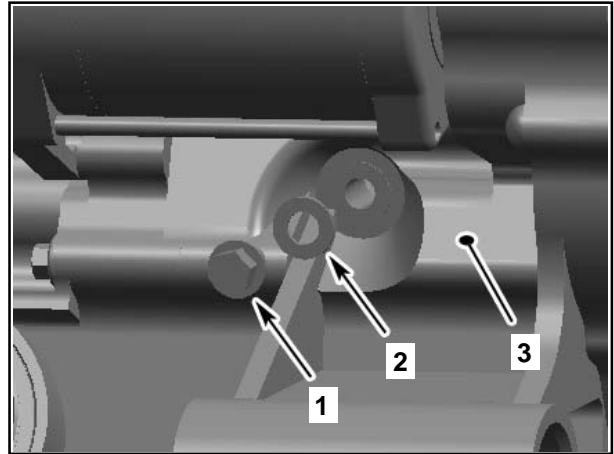

- 1. Screw
- 2. Washer
- 3. Left crankcase

Use 18mm socket to rotate crankshaft until piston of cylinder No.2 is at TDC ignition.

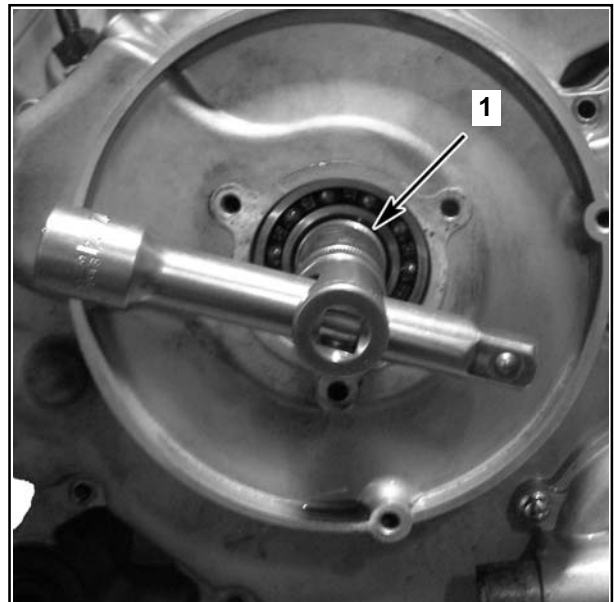

- 1. 18mm Socket

When piston of rear cylinder is at TDC, Marks on magneto flywheel and magneto cover are aligned.

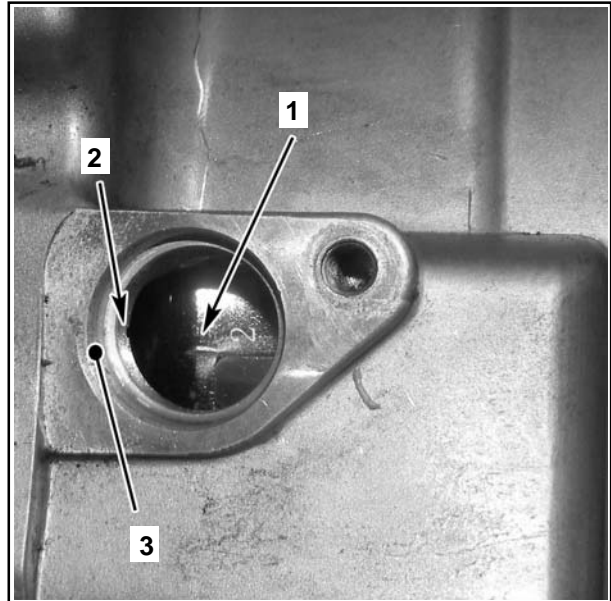

1. Mark "2" on magneto flywheel
2. Notch on magneto cover
3. CPS Location

Use screwdriver to check if V-type groove of crankshaft balancer is aligned with the hole.

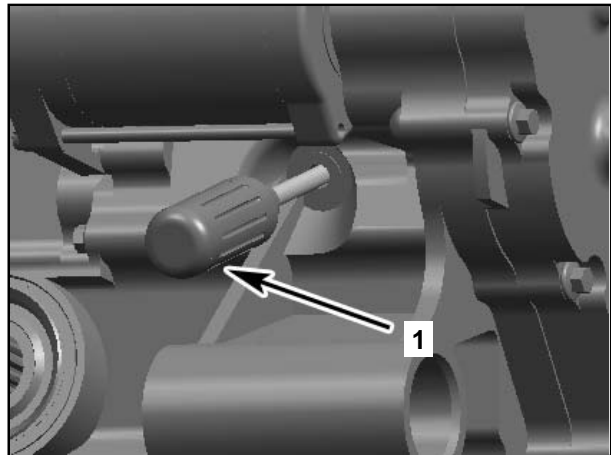

1. Screwdriver

Lock crankshaft with crankshaft locking bolt (P/N:0800-041000-922-001).

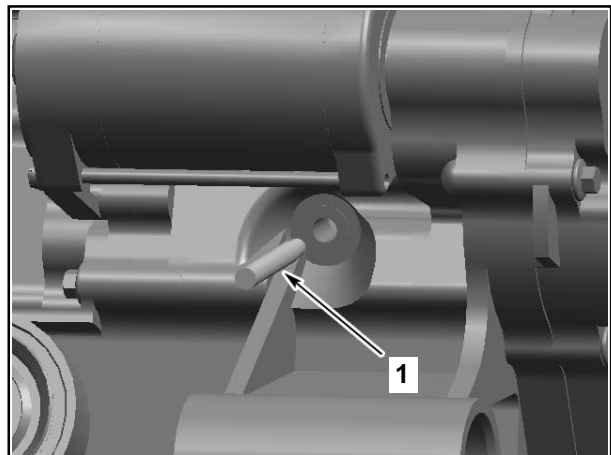

1. Crankshaft locking screw

Crankshaft Removal

Refer to **CRANKCASE**.

Crankshaft Inspection

NOTE: Check each bearing journal of crankshaft for scoring, scuffing, cracks and other signs of wear.

NOTE: Replace the crankshaft if the gears are worn or otherwise damaged.

CAUTION: Components with less than the service limit always have to be replaced. Otherwise severe damage may be caused to the engine.

Crankshaft Axial Play

NOTE: Axial play of crankshaft needs to be measured before splitting the crankcase.

Use dial gauge to measure crankshaft axial play at MAG side.

Crankshaft Axial Play	
New	0.050-0.350 (0.002-0.014in)
Service Limit	0.6mm(0.024in)

If play is out of specification, replace crankcase and/or crankshaft.

Connecting Rod Big End Axial Play

Using a feeler gauge, measure the distance between butting face of connecting rods and crankshaft counterweight.

Connecting Rod Big End Axial Play	
New	0.300-0.560 (0.012-0.022in)
Service Limit	0.8mm(0.031in)

Connecting Rod/Piston Pin Clearance

Refer to **INTAKE MANIFOLD, CYLINDER HEAD AND CYLINDER**.

Connecting Rod Big End Radial Play

Remove connecting rod from crankshaft.

NOTE: Make sure the same marking of connecting rod to assemble together, do not mix it and exchange between cylinder 1 and cylinder 2.

CAUTION: Always replace connecting rod screws no.1 if removing connecting rod.

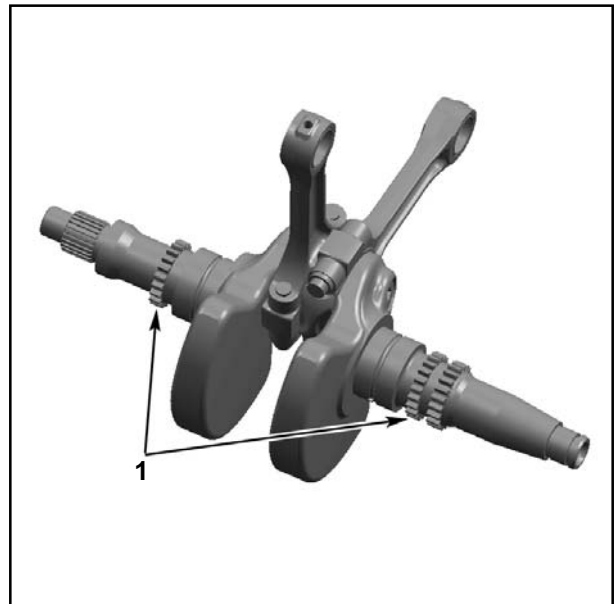

1. Timing sprocket (gear) of crankshaft

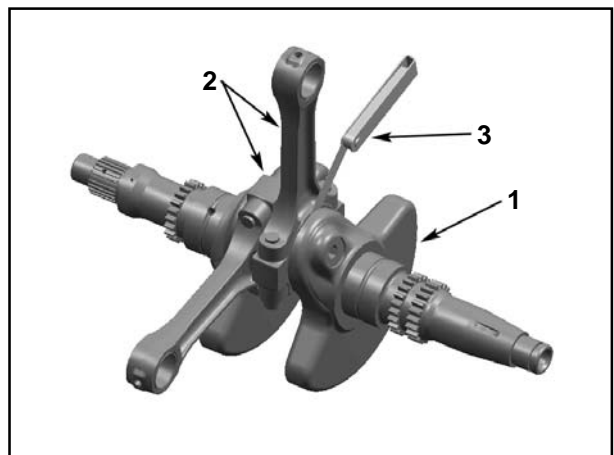

1. Crankshaft
2. Connecting Rod
3. Gauge

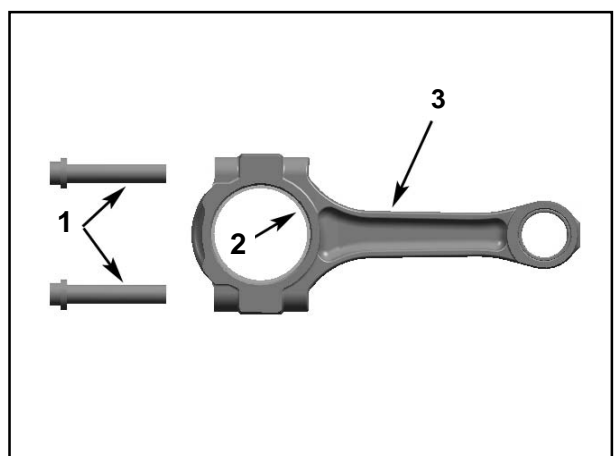

1. Connecting Rod Screws
2. Plain Bearing
3. Connecting Rod

Measure the diameter of crankpin and compare to inner diameter of connecting rod big end.

Install screws of connecting rod and measure inner diameter of connecting rod big end.

Install bearing of connecting rod as original condition. Use below-mentioned methods and torque to tighten.

Crankpin	
Standard	43.946-43.960mm (1.7302-1.7307 in)
Service Limit	43.93mm(1.7295 in)
Inner Diameter of Connecting Rod Big End	
Service Limit	44.03mm(1.7335 in)
Clearance between Connecting Rod Big End and Crankpin	
Service Limit	0.09mm(0.0035 in)

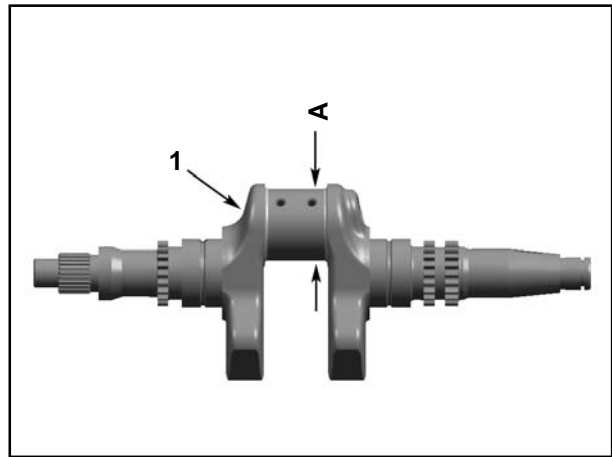

1.Crankshaft
A.Diameter of connecting shaft neck

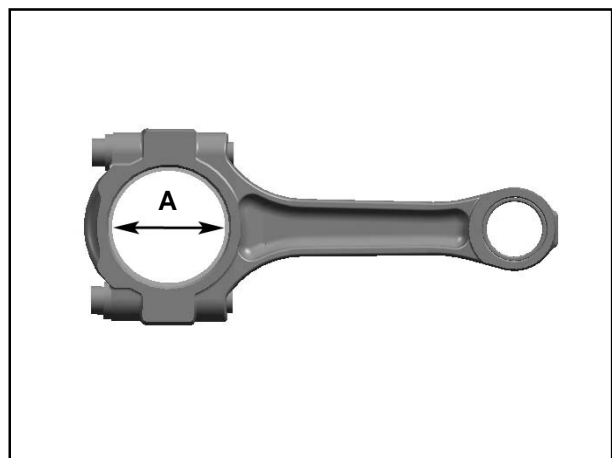

1.Inner Diameter of Connecting Rod Bid End

Crankshaft Radial Play, MAG/PTO Side

Measure crankshaft on MAG/PTO side and compare to inner diameter of MAG/PTO plain bearing(see **CRANKCASE**).

Diameter of Crankshaft MAG/PTO Side	
Standard	41.960-41.970mm (1.652-1.6524 in)
Service Limit	41.935mm(1.651 in)

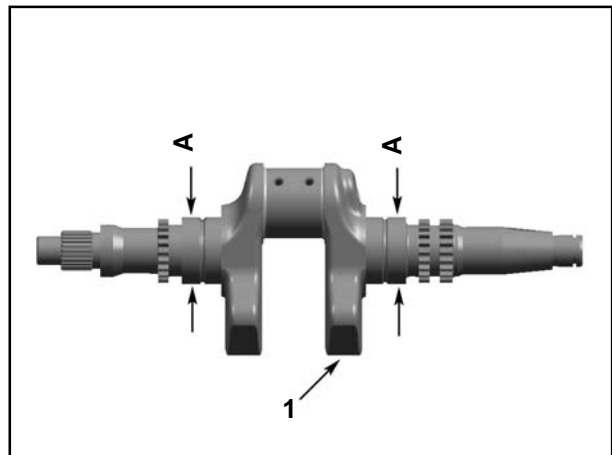

1.Crankshaft
A.Diameter of PTO Side Crankshaft
B.Diameter of MAG Side CrankshaftMAG

Clearance between Crankshaft and Crankcase Hole	
Service Limit	0.09mm(0.0035 in)

Crankshaft Assembly

NOTE: Follow the table below to assemble crankshaft, connecting rod and connecting rod plain bearing.

Inner Diameter of Connecting Rod Big End	Crankpin	Bearing of Connecting Rod
I	A	Black
II	B	Blue
I	A	Red
II	A	Black

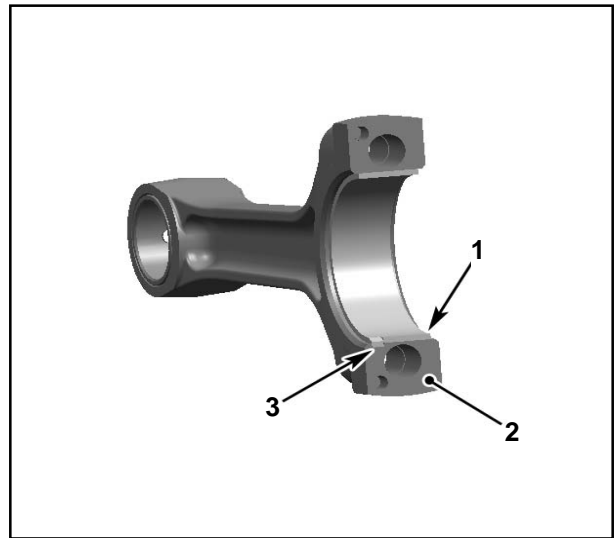

1. Half Plain Bearing of Connecting Rod Big End
2. Split Surface of the Connecting Rod
3. Nose of Plain Bearing in Line with Connecting Rod Groove

Crankshaft assembly procedure is the reverse of disassembly procedure. However, the following details should be noted.

1. When inner diameter of connecting rod big end is less than service limit, replace and use new connecting rod bearing.
2. After installing bearing into big end of connecting rod, use compressed air to clean connecting rod split surface.

NOTE: Oil on inner surface of connecting rod plain bearing and crankshaft pin surface before installation.

There are oil passage plug at CFMOTO logo side of cylinder 1 and cylinder 2 connecting rod.

Screw of connecting rod should be tightened by following methods.

-Firstly torque to $10\text{N}\cdot\text{m}$ ($7.5\text{lbf}\cdot\text{ft}$).

DO NOT apply threadlocker.

-Then, torque to $20\text{N}\cdot\text{m}$ ($15\text{lbf}\cdot\text{ft}$).

-Finally torque to $50\text{N}\cdot\text{m}$ ($35.25\text{lbf}\cdot\text{ft}$).

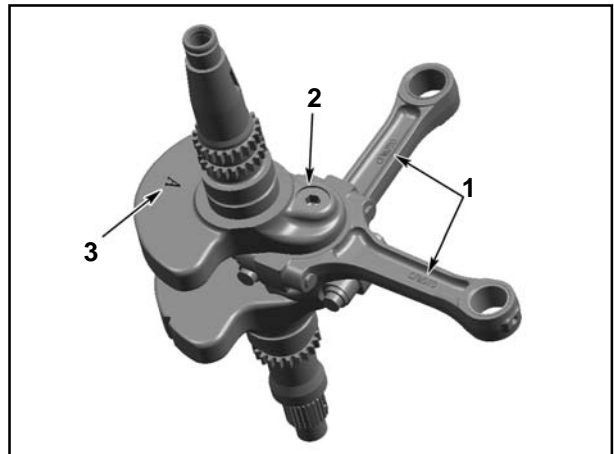

1. CFMOTO Logo
2. Plug of Oil Passage
3. Mark A or B on connecting shaft

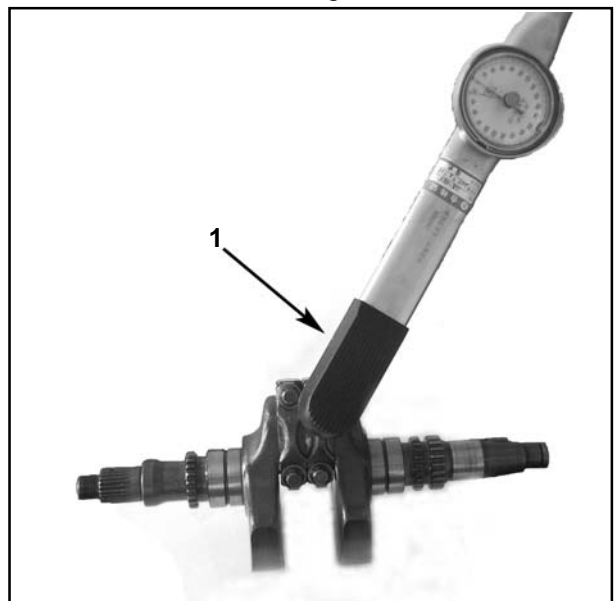

1. Torque Wrench

CAUTION: Improper installation will cause screw looseness and engine damage.

ATTENTION: Bearing of connecting rod big end and piston pin rotation cannot be changed.

Crankshaft Installation

The procedure of crankshaft installation is the reverse of removal, but following details should be cared.

Do not mix connecting rod of cylinder No. 1 and No.2

ATTENTION:Do not damage plain bearing of crankcase when installing crankshaft (together with connecting rod).

ATTENTION:Before installation of camshaft and valve rocker arm, do not forget to install locking bolt to make sure crankshaft on top dead position.

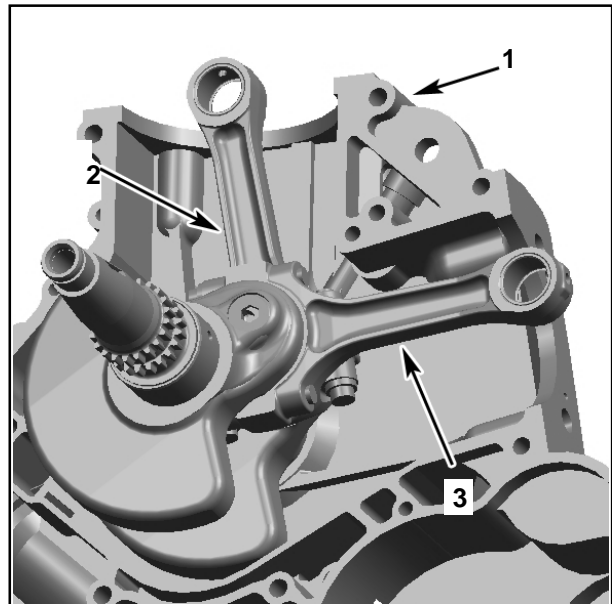

- 1.Crankcase
- 2.Connecting rod of cylinder No.1
- 3.Connecting rod of cylinder No.2

Engine Front Output Shaft Removal

Remove shaft collar, O-ring, oil seal and bearing retainer.

Remove front output shaft.

Inspection

Inspect if bearing turns freely and smoothly, or has abnormal wear. Replace if necessary.

Installation

Reverse the removal procedure for installation. Pay attention to the following details.

Before installation, Oil bearing. Meanwhile, use a new oil seal and grease should be applied on lip of oil seal.

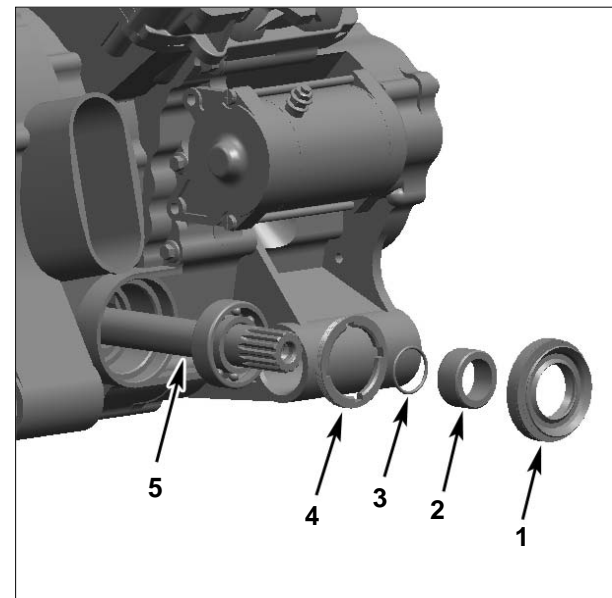

- 1.Oil Seal
- 2.Shaft Collar
- 3.O-ring
- 4.Bearing Retainer
- 5.Front Output Shaft

Use service tool to tighten bearing retainer (left thread) by applying threadlocker.

Tightening Torque: 80N•m

Service Tool:

Bearing retainer socket: 0180-060008-922-001

Oil seal installer: 0800-060000-923-001

Installer, front output shaft: 0800-062301-923-001

Ring Gear Removal

Remove ring gear bearing carrier screws;

Remove ring gear and adjustment shimshaft; Remove output shaft collar, O-ring, and oil seal;

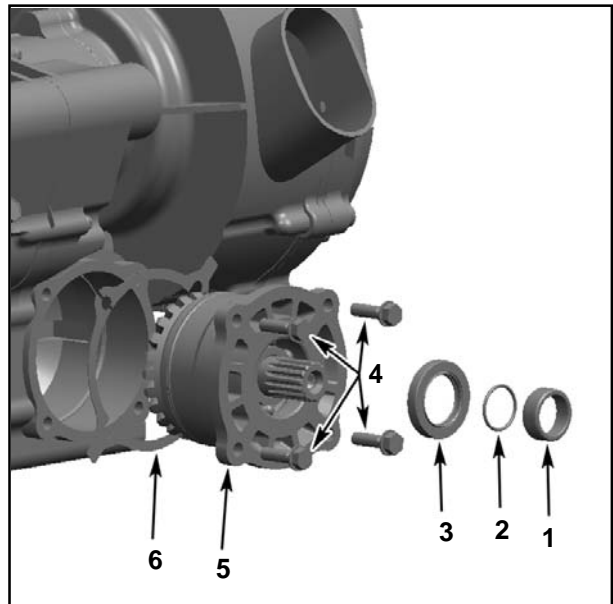

1. Shaft Collar
2. O-ring
3. Oil seal
4. Screws
5. Ring Gear Comp.
6. Adjustment Shim

Use protector to avoid ring gear damage, fasten bearing carrier and press ring gear out;

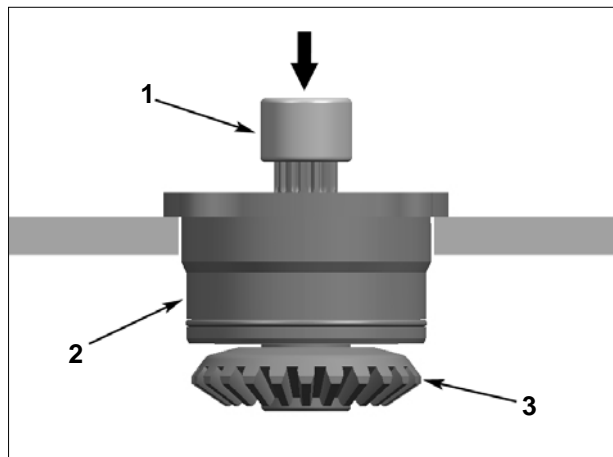

1. Ring Gear Protector
2. Bearing Carrier
3. Ring Gear

Use bench vice to fix bearing carrier, then remove bearing and use special wrench (0800-062206-922-001) to remove thrust nut, finally remove bearing.

Ring Gear Inspection

Inspect gear for any surface damage, wear. Replace if necessary.

Inspect bearing for operation condition.

Ring Gear Installation

Installation procedure is the reverse of removal procedure. Pay attention to the details.

Use oil seal installer (0800-062204-923-001) to install **NEW** oil seal and O-ring.

When replacement of right crankcase, ring gear or bearing seat, adjustment shim should be checked and adjusted.

Service Tool:

Drive pinion gear bearing(6305) installer:

0180-062103-921-002

Ring gear bearing(6207C3) installer:

0180-062201-921-003

When installation, apply oil on bearing, oil seal, o-ring; apply threadlocker on bearing thrust nut and tighten to below torque.

Tightening Torque: **110N•m**

Drive Pinion Gear Removal

Separate left and right crankcase(see **CRANKCASE**);

Remove drive pinion gear bearing carrier screws;

Remove drive pinion gear;

Remove circlip of drive pinion gear and output driven gear;

Use a clean rag to protect drive pinion gear shaft and fix it on bench vice;

Loosen drive pinion gear nut and remove drive pinion gear and adjustment shim;

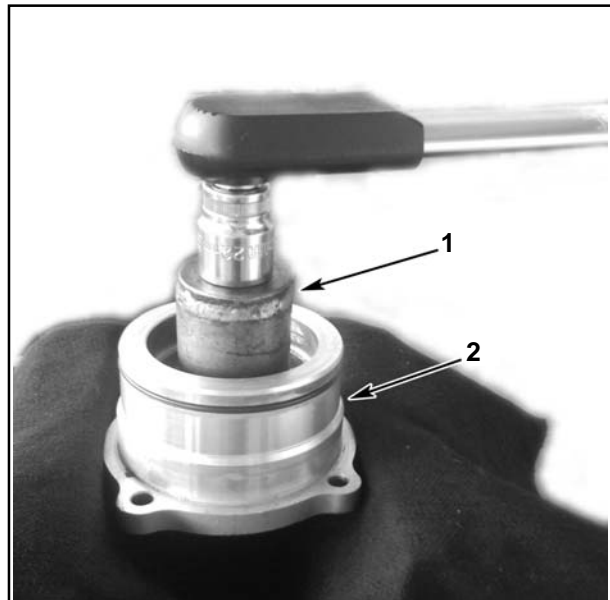

1. Special Tool
2. Bearing Carrier of Ring Gear

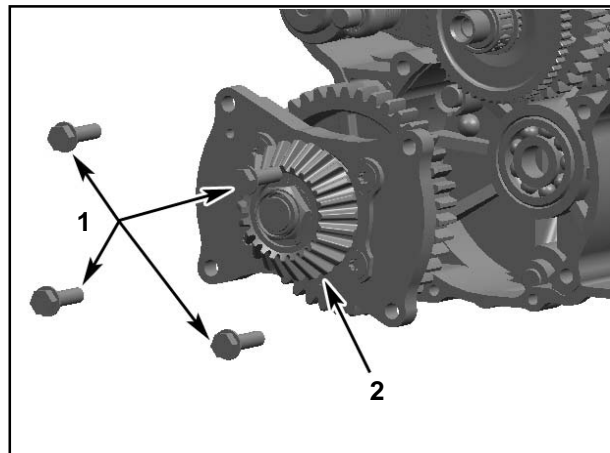

1. Screws
2. Drive Pinion Gear

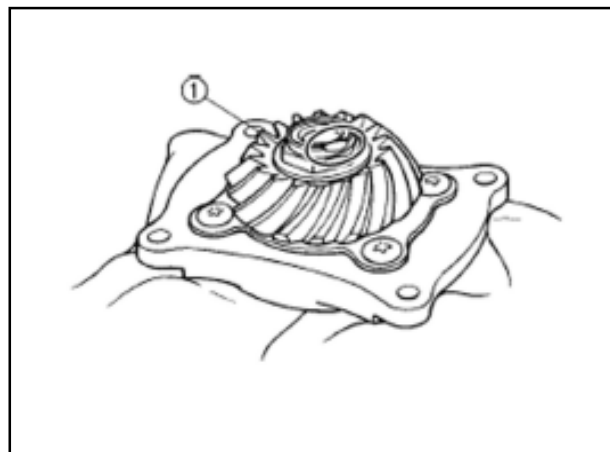

1. Nut

Drive Pinion Gear Inspection

Inspect drive pinion gear and output driven gear teeth for rusting, scratches, wear. Replace if necessary.

Inspect if bearing turns freely and smoothly. Replace if necessary.

When replacing any of crankcase, drive pinion gear, and drive pinion gear carrier, the adjustment shim should be readjusted. Refer to the content further.

Drive Pinion Gear Installation

Reverse the removal procedure for installation. Oil bearing and tighten nut to specified torque.

Tightening Torque: 145N • m.

Shim Adjustment Procedure

When crankcase and/or drive pinion gear and/or ring gear and/or bearing carrier are replaced, the shim must be adjusted.

WARNING

Both gear backlash and tooth contact should be in specification.

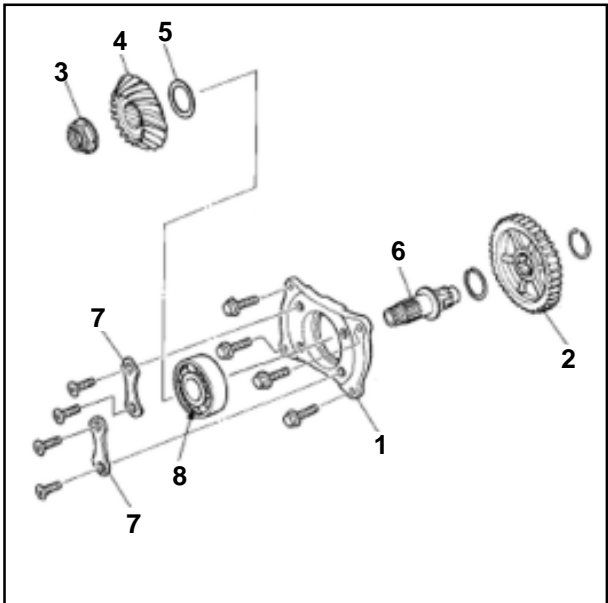

- 1. Drive Pinion Gear Carrier 5. Adjustment Shim
- 2. Output Driven Gear 6. Drive Pinion Gear Shaft
- 3. Drive Pinion Gear Nut 7. Bearing Retaining Plate
- 4. Drive Pinion Gear 8. Ball Bearing

Gear Backlash

Install drive pinion gear and ring gear then install crankcase gasket;

Close crankcase and install some screws;

To lock drive pinion gear, using a clean screwdriver, reach the hole of drive pinion gear seat through speed sensor hole, then pry output driven gear out of place in its axial direction;

Install gear backlash measurement tools and dial gauge;

Rotate ring gear shaft from engagement to engagement to measure gear backlash.

NOTE: Measure the gear backlash at 4 positions. Rotate the shaft 90° each time.

If gear backlash is out of specification, make the adjustment by adjusting the thickness of ring shim.

Gear Backlash: 0.1-0.2mm (0.004-0.008in)

Adjustment Steps

Gear Backlash	Shim Adjustment
< 0.1mm	Increase shim thickness
0.1-0.2mm	Correct
> 0.2mm	Reduce shim thickness

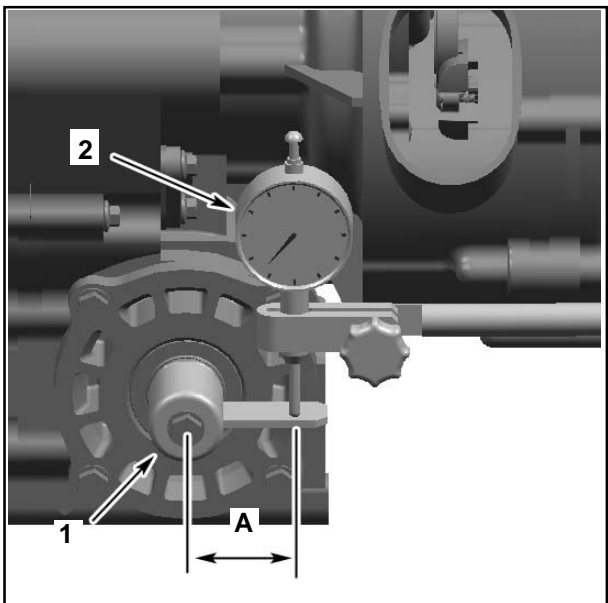

- 1. Backlash Measurement Tool
- 2. Dial Gauge
- A. 46mm (1.81 in)

Tooth Contact

After backlash adjustment is carried out, the tooth contact must be checked. Pay attention to the following procedures:

Remove ring gear from crankcase;

Clean and degrease drive pinion gear and ring gear teeth;

Apply a coating of machinist's layout dye or paste to several teeth of the driven gear;

Install ring gear;

Rotate the ring gear several turns in both directions;

Remove drive pinion gear and ring gear, then inspect the coated teeth of the drive pinion gear. The tooth contact pattern should be as shown below;

Pattern 1	Contact at tooth top	Incorrect
Pattern 2	Contact at tooth middle	Correct
Pattern 3	Contact at tooth root	Incorrect

If gear tooth contact is found to be correct (pattern 2), continue the next step.

If gear tooth contact is found to be incorrect (pattern 1 and pattern 3), the shim thickness between the drive pinion gear and ring gear must be changed and the tooth contact re-checked until correct.

NOTE: Clean the dye coated on the gear teeth after the tooth contact adjustment is finished.

Adjustment Steps

Tooth Contact	Shim Adjustment
Pattern 1	Reduce shim thickness
Pattern 3	Increase shim thickness

CAUTION: Make sure to check the backlash after the tooth contact has been adjusted, since it may have changed. Adjust the tooth contact and backlash until they are both within specification. If the correct tooth contact cannot be maintained when adjusting the backlash, replace the drive gear and ring gear.

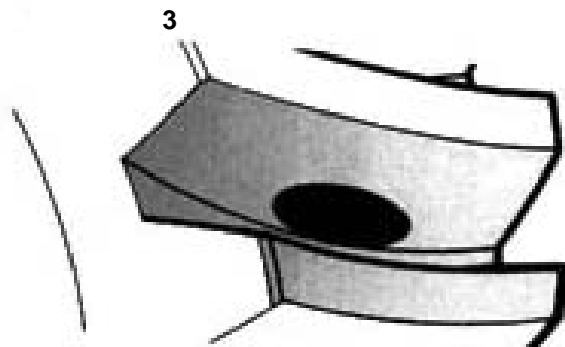
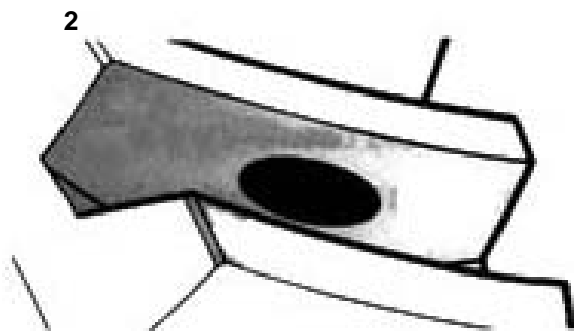

Shift Lever Assembly Removal

Remove shift lever cover screws;
Remove shift lever cover and gasket;

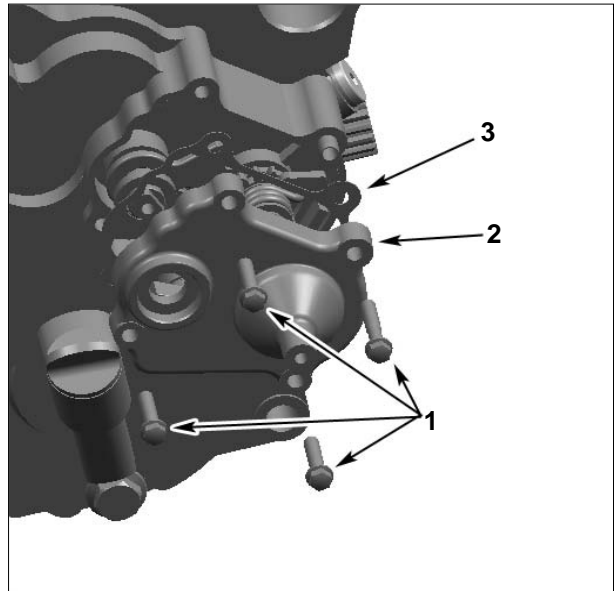

- 1.Screws
- 2.Shift Lever Cover
- 3.Shift Lever Gasket

Remove driven shift lever assembly;
Remove drive shift lever assembly.

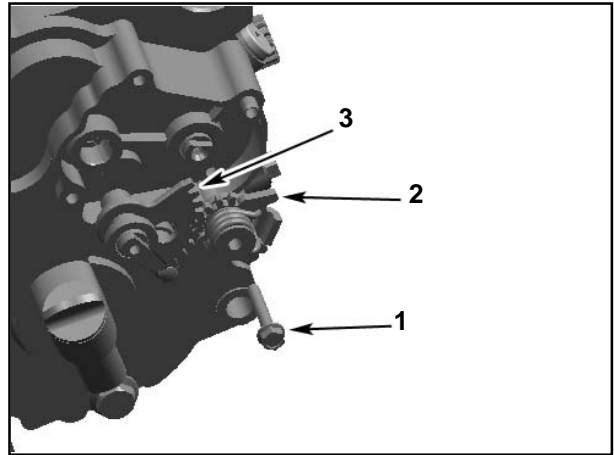

- 1.Screw
- 2.Driven Shift Lever Assembly
- 3.Drive Shift Lever Assembly

Main Shaft,Driven Shaft Assembly,Shift Drum,Shift Fork/Shaft Removal

Remove gearshift limit spring seat;
Remove limit spring and steel ball;

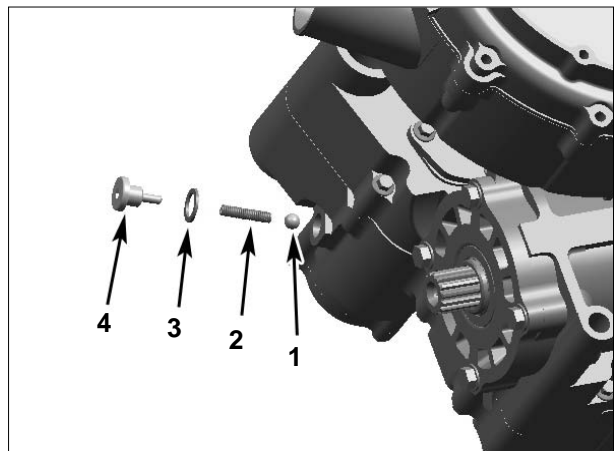

- 1.Steel Ball
- 2.Spring
- 3.Washer
- 4.Spring Seat

Split crankcase(see **CRANKCASE**);
Remove gearshift driven shaft washer,driven lo range gear;

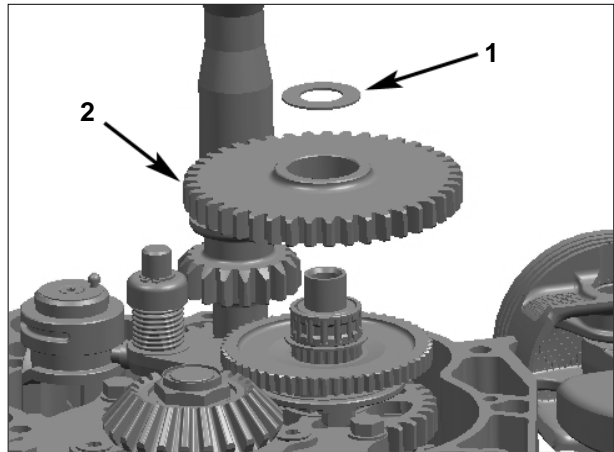

1.Washer
2.Driven Lo Range Gear

Remove drive pinion gear assy;
Remove gearshift main shaft by shifting to lo gear range;

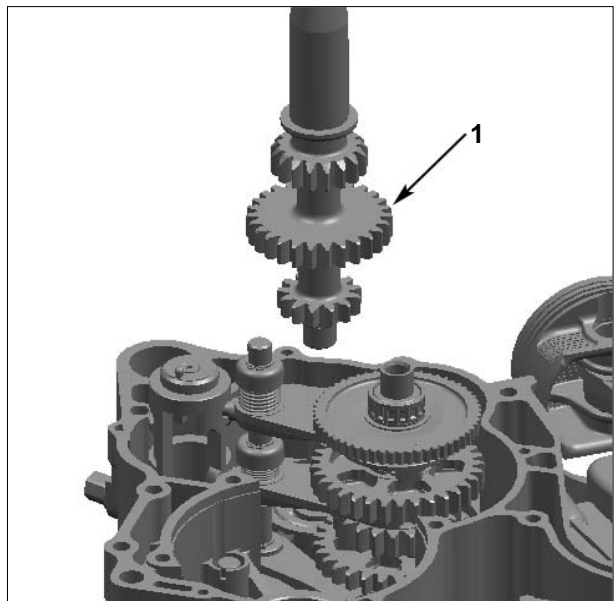

1.Main Shaft

Remove gearshift driven shaft assy,shift drum,shift forks,parking lock lever;

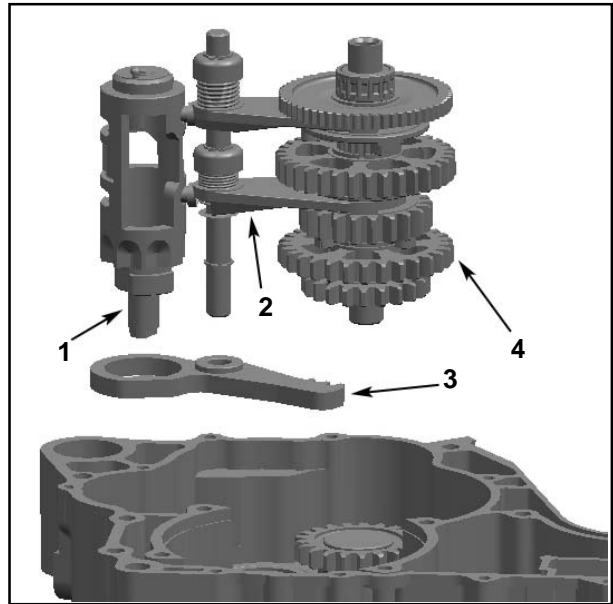

- 1.Shift Drum
- 2.Shift Fork
- 3.Parking Lock Lever
- 4.Driven Shaft Assy

Reverse Intermediate Gear Removal

NOTE: *If reverse intermediate gear and needle bearing turn freely and smoothly,and clearance of them is normal,no need to remove them.*

To remove reverse intermediate gear and needle bearing,a proper service tool is required to press it out of left crankcase.(Use care to protect reverse intermediate gear and needle bearing from damage.)

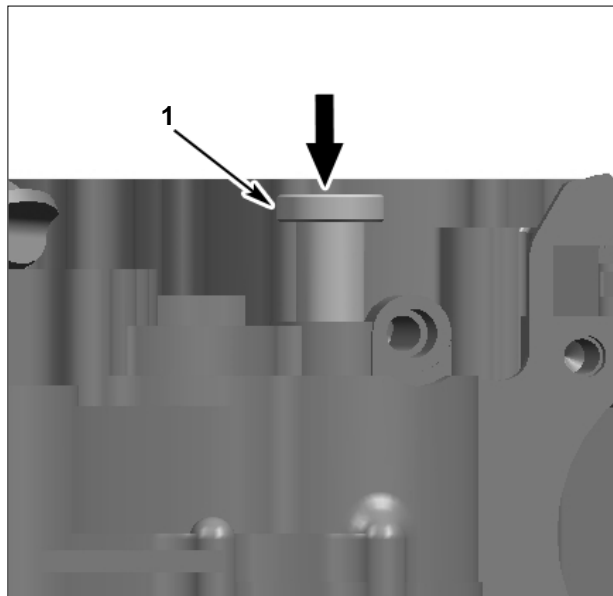

- 1.Service Tool

Bearing Removal in Crankcase

If necessary, heat crankcase up to 100°C (212°F) before bearing removal.

WARNING

Clean oil, outside and inside, from crankcase before heating.

CAUTION: Always support crankcase properly when bearing is removed. Crankcase damages may occur if this procedure is not performed correctly.

To remove ball bearing in crankcase, use a blind hole bearing puller.

Inspection

Always verify for the following when inspecting components in crankcase:

- gear teeth damage
- worn or scoured bearing surface
- excessively worn, scoured, or bent shift fork
- excessively worn, scoured, or bent shift fork shaft
- rounded engagement dogs and slots
- excessively worn, scoured parking lock lever
- worn shift fork engagement pins
- worn shift track on shift drum
- worn or scoured shift fork claw
- worn splines on shafts and gears
- excessively worn and scoured parking cam

Bearing

Check if bearing turns freely and smoothly. If any binding or abnormal noise has been found, replace it with a new one.

Shift Fork/Shaft

Check both shift forks for excessive wear. Check shift fork claw for bending.

Measure shift fork claw thickness.

Shift Fork Claw Thickness(both forks)	
New	5.8-5.9mm(0.228-0.232in)
Service Limit	5.7mm(0.224in)

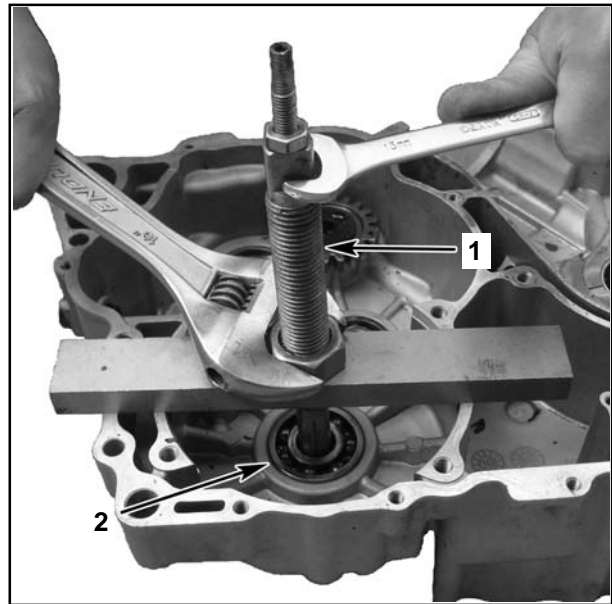

1. Bearing Puller
2. Ball Bearing

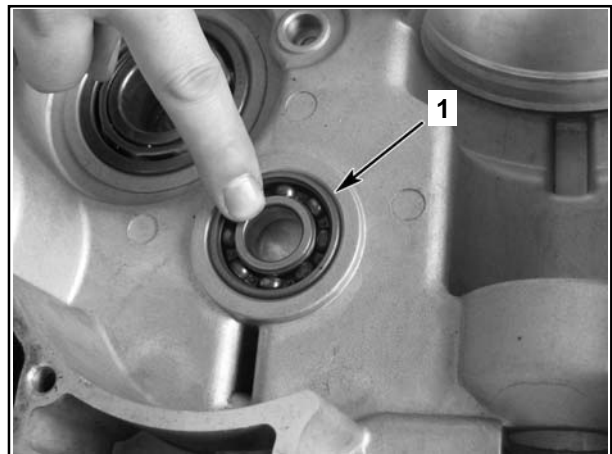

1. Bearing

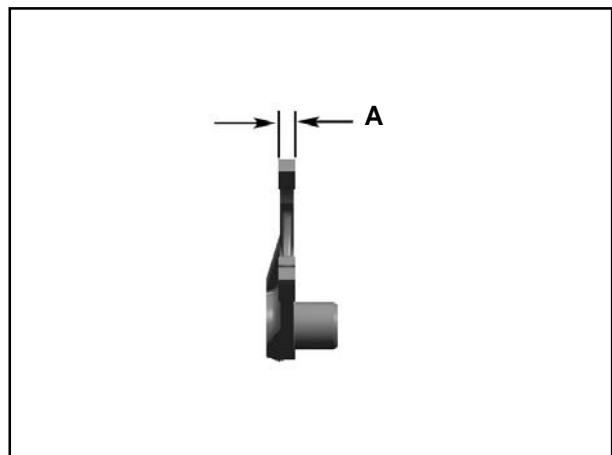

A. Shift Fork Claw

Measure shift fork pins.

Shift Fork Pin Diameter(both)	
New	7.9-7.95mm(0.311-0.313 in)
Service Limit	7.83mm(0.318 in)

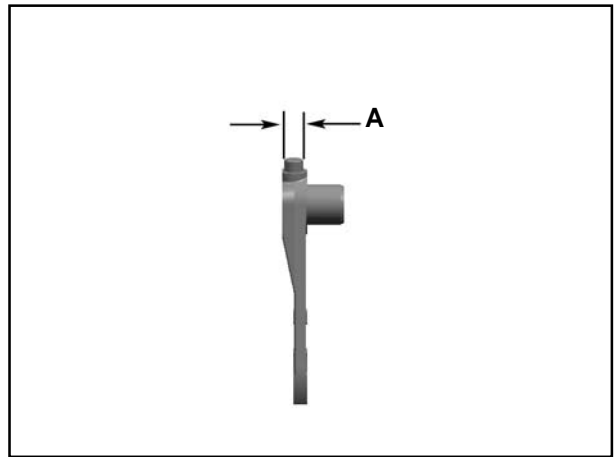

A.Diameter of Shift Fork Pin

Fit shift fork onto the shift fork shaft,then move the shaft as illustrated.Check if shift fork slides smoothly. Replace if necessary.

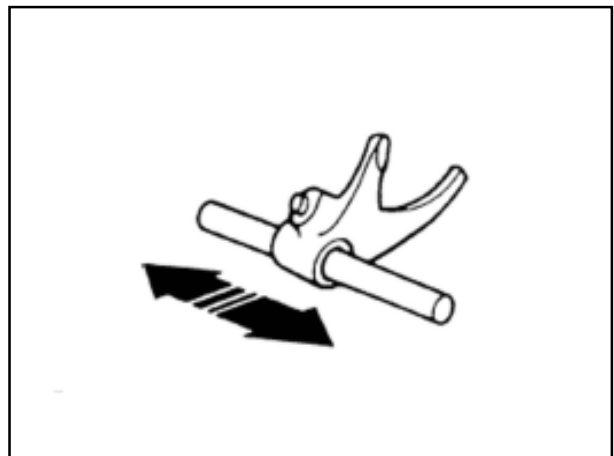

Place shift fork shaft on a level surface and roll it.If any bending has been found,replace it with a new one.

CAUTION: Do not try to correct the bend shift fork pin.

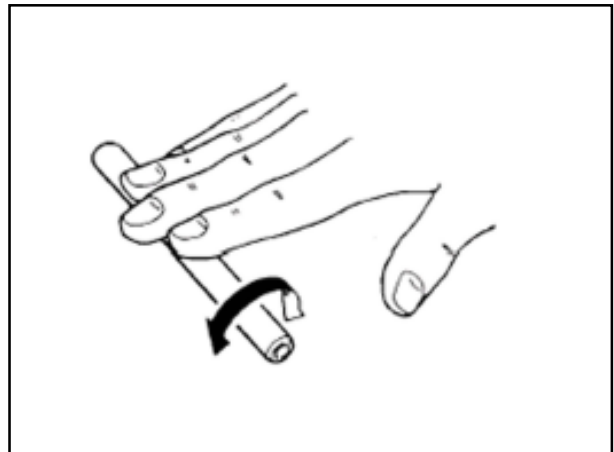

Inspect shift fork springs for damages. Replace if necessary.

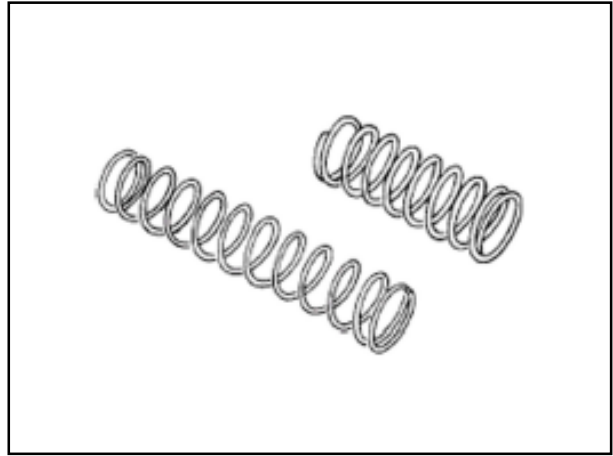

Shift Drum

Inspect shift drum tracks for excessive wear and other damages.

Inspect parking lock cam on shift drum for excessive wear and other damages. Replace if necessary.

Inspect limit washer for damages.

Replace if necessary.



Parking Lock Lever

Check parking lock lever for cracks or other damages.

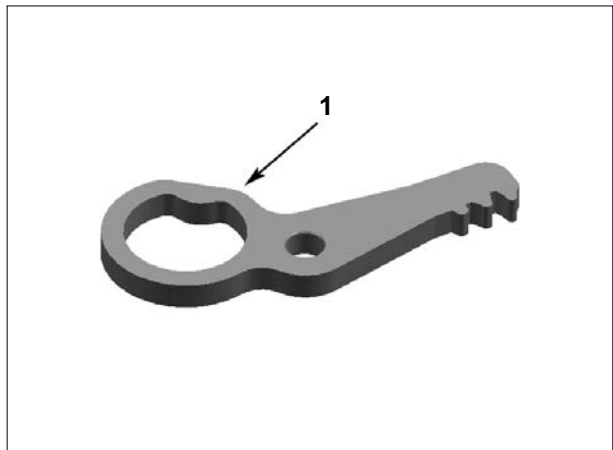

1. Parking Lock Lever

Gearshift Main Shaft

Check gearshift main shaft for damages.

Check gear teeth of gearshift main shaft for pittings, scuffing and excessive wear. Replace if necessary.

Measure main shaft neck diameter of two ends as shown. If the measurements are less than the service limit, replace.

Gearshift Main Shaft Neck Diameter	
Service Limit	
MAG Side	16.97mm(0.666 in)
CVT Side	29.97mm(1.178 in)

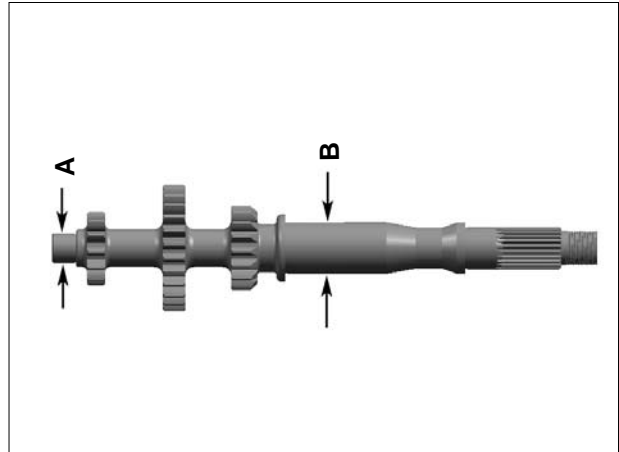

A. MAG Side

B. CVT Side

Gearshift Driven Shaft Assy

Disassemble gearshift driven shaft assy as shown.

Check teeth of each gear for fittings, scuffing and excessive wear. Check needle bearing and circlip for wear and damages. Replace if necessary.

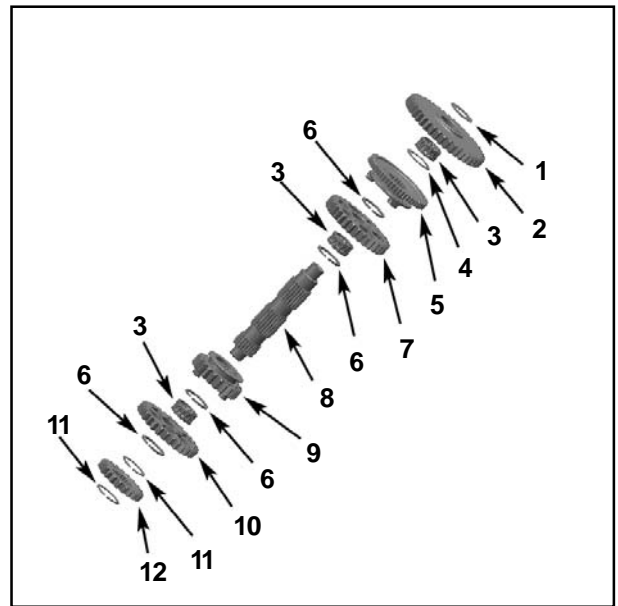

1. Washer 17.5x32x1

2. Driven Lo Range Gear

3. Needle Bearing

4. Washer 24.5x33.5x1

5. Gearshift Sliding Bushing

6. Circlip 29

7. Driven Hi Range Gear

8. Driven Shaft

9. Driven Output Gear

10. Reverse Driven Gear

11. Circlip 29

12. Parking Lock Gear

Gears

NOTE: Gears must be replaced in a pair. Always replace circlip after removal.

- driven shaft output gear for reverse gear shifting
- gearshift sliding sleeve for high and low gear shifting

Measure the width for engagement of shift fork. If the width is out of specification, replace the gear.

The width for engagement of shift fork on the gear should be the same with the one on the sliding sleeve.

Width for Engagement of Shift Fork	
New	6.1-6.2mm(0.240-0.244 in)
Service Limit	6.3mm(0.248 in)

Inspect reverse driven gear, high range gear, low range gear for damages. Measure the gear inner diameter, if it's out of specification, replace the gear.

The inner diameter of reverse driven gear, high range gear, low range gear is the same.

Inner Diameter	
New	29-29.021mm(1.1417-1.1425 in)
Service Limit	29.025mm(1.1427 in)

Driven Shaft

Check driven shaft for damages.

Check driven shaft for pittings, scouring and excessive wear. Replace if necessary.

Measure driven shaft neck diameter, if it's out of specification, replace it.

Driven Shaft	
Service Limit	
A	16.978(0.6684 in)
B	23.970(0.9437 in)

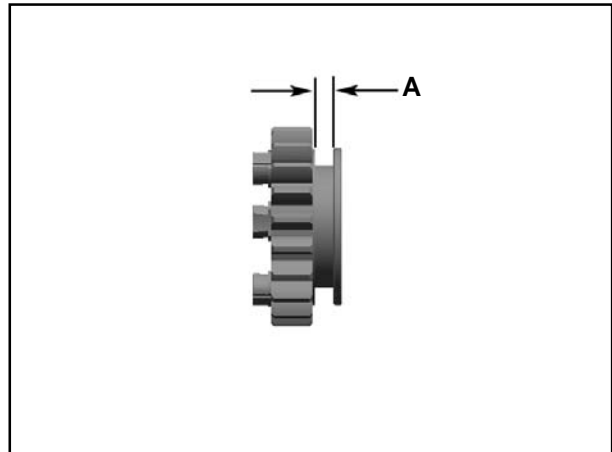

A. Groove Width

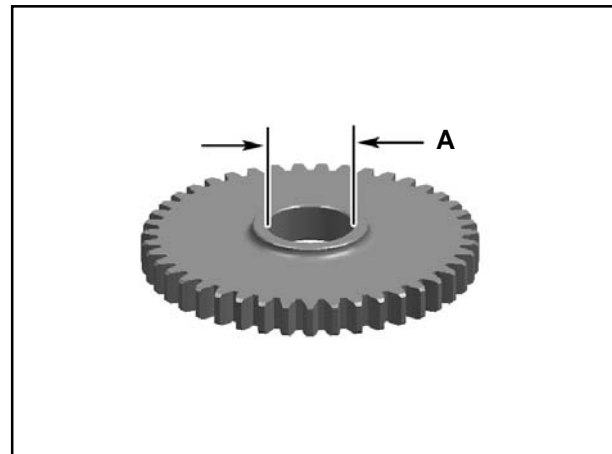

A. Inner Diameter

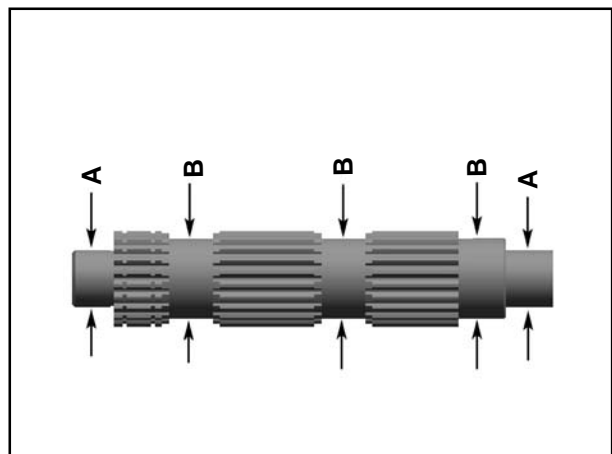

Reverse Intermediate Gear

Check reverse intermediate gear for damages.Measure the inner diameter.If it's out of specification,replace it.

Reverse Intermediate Gear Inner Diameter	
New	29.007-29.028 mm(1.1420-1.1428 in)
Service Limit	29.032 mm(1.1430 in)

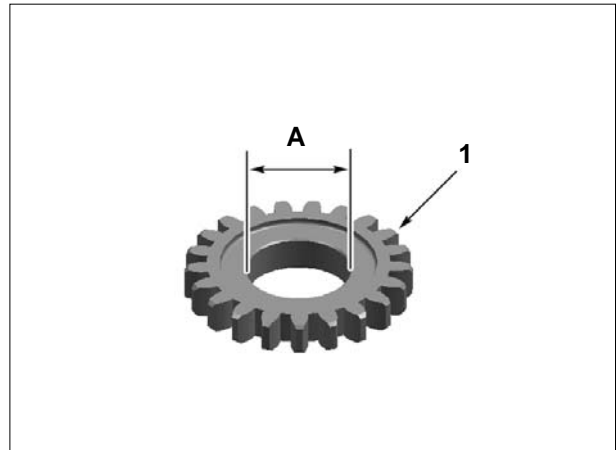

1.Reverse Intermediate Gear
A.Inner Diameter

Reverse Intermediate Gear Shaft

Check reverse intermediate gear for damages.Measure reverse intermediate gear shaft neck diameter. If it's out of specification,replace it.

Reverse Intermediate Gear Neck Diameter	
New	24.980-24.993 mm(0.9834-0.984 in)
Service Limit	24.974 mm(0.9832)

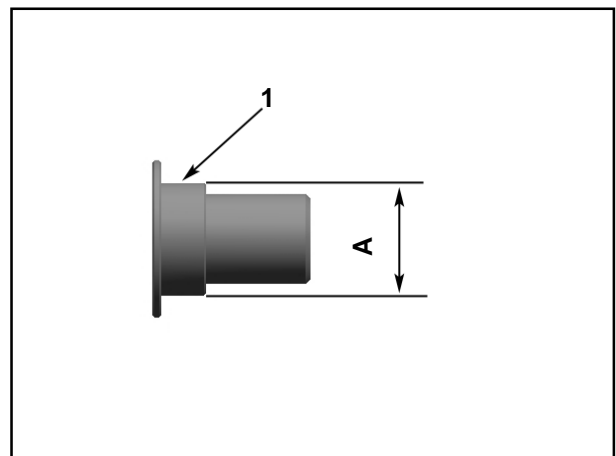

1.Reverse Intermediate Gear Shaft
A.Reverse Intermediate Gear Shaft Neck Diameter

Shift Lever Assembly

Check shift lever cover for cracks,deformation and other damages.Replace if necessary.

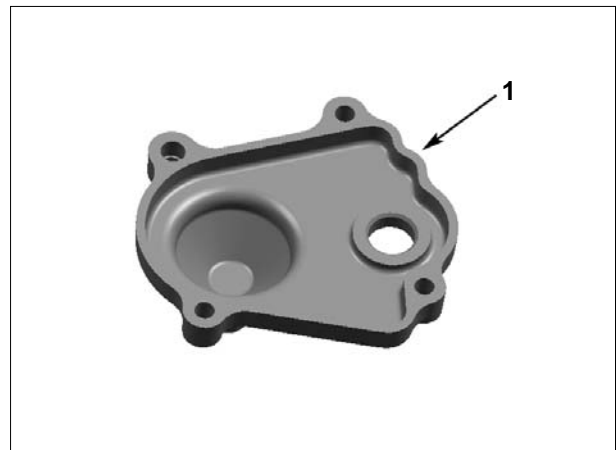

1.Shift Lever Cover

Check drive shift lever and driven shift lever for cracks, deformation, wear and other damages. Replace if necessary.

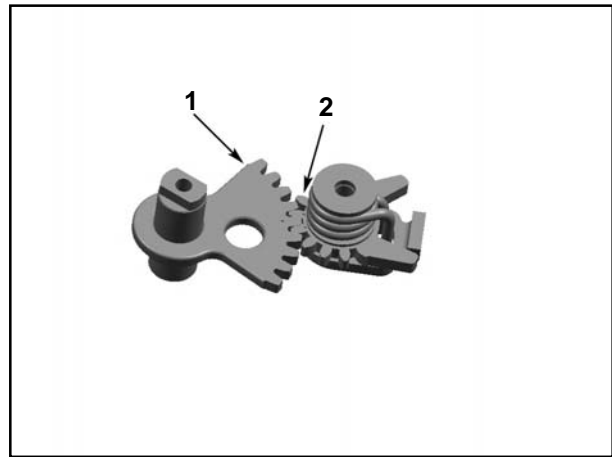

1. Drive Shift Lever
2. Driven Shift Lever

Assembly

Assembly procedure is the reverse of disassembly procedure. Pay attention to the following details:

Always use a new circlip. Pay attention to the direction when installing a new circlip. Perform the installation as illustrated.

Lightly oil gears and shafts before assembly.

CAUTION:

Once circlip is removed, it has been damaged. Therefore, never use it for a second time. When installing a new circlip, do not open the circlip too much.

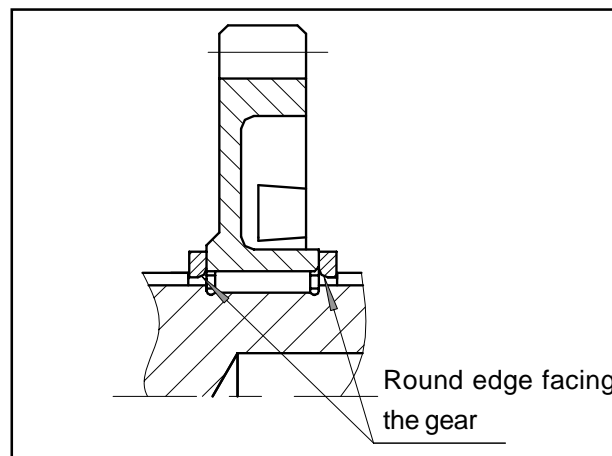

Round edge facing the gear

After circlip installation is finished, make sure the circlip is in place.

When installing shift fork shaft, ensure shift forks and shift fork springs are in correct locations as illustrated.

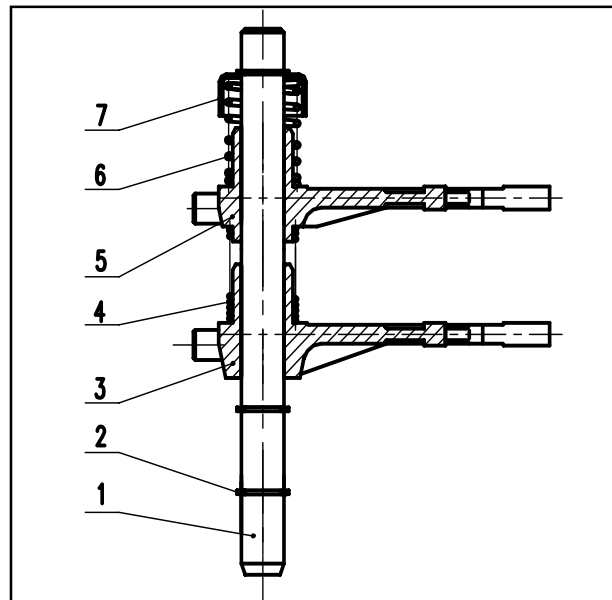

1. Shift Fork Shaft 2. Circlip 12;
3. Left Shift Fork 4. Shift Fork Spring (thin)
5. Right Shift Fork 6. Shift Fork Spring (thick)
7. Spring Seat

Installation

Crankcase installation procedure is the reverse to removal installation procedure. However, pay attention to the following details:

Do not use a hammer to install ball bearing unless its structure is special. Only use a press tool to install a bearing.

If necessary, heat crankcase up to 100°C (212°F) before removing ball bearing.

WARNING

Clean oil, inside and outside, from crankcase before heating.

Put a new ball bearing in an icebox or equivalent facility to chill for 10 minutes before installation.

Using service tool, install the ball bearings in left crankcase and right crankcase.

CAUTION: Always support crankcase properly when installing ball bearings.

Perform the correct procedure when installing a new oil seal (Refer to *Oil Seal Installation* above).

Other Parts in Crankcase

Fit needle bearing onto reverse intermediate gear shaft, then install them together with reverse intermediate gear.

NOTE: Reverse intermediate gear collar faces reverse intermediate gear shaft small end.

NOTE: Press bearing no.3 before installing reverse intermediate gear.

Using press machine, press reverse intermediate gear in the left crankcase.

Place parking lock lever in place in crankcase.

Engage shift fork assy with gearshift driven shaft assy, then fit them in place in left crankcase.

NOTE: Do not install washer 17X32X1 and reverse range gear into gearshift driven shaft assy.

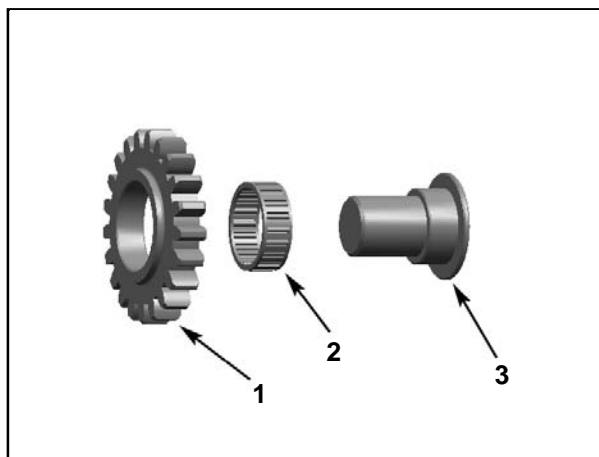

1. Reverse Intermediate Gear
2. Needle Bearing
3. Reverse Intermediate Gear Shaft

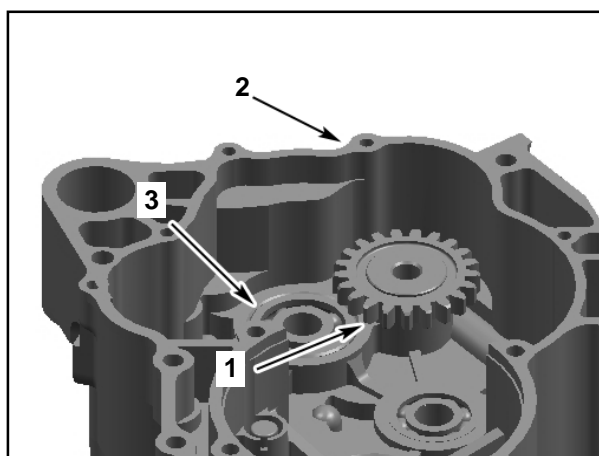

1. Reverse Intermediate Gear
2. Left Crankcase
3. Bearing

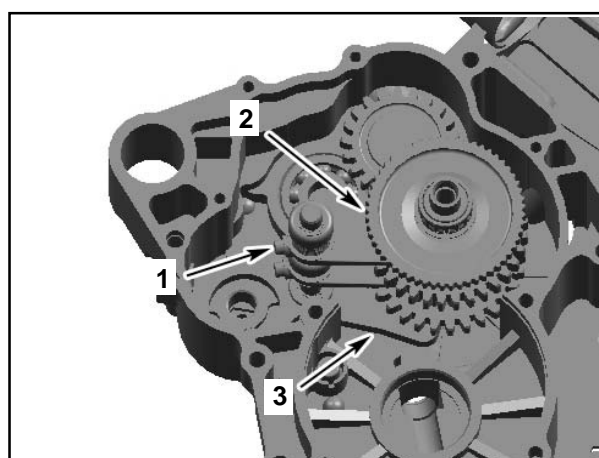

1. Shift Fork Assy
2. Driven Shaft Assy
3. Parking Lock Lever

Install drive pinion gear assembly then tighten the 4 retaining screws.

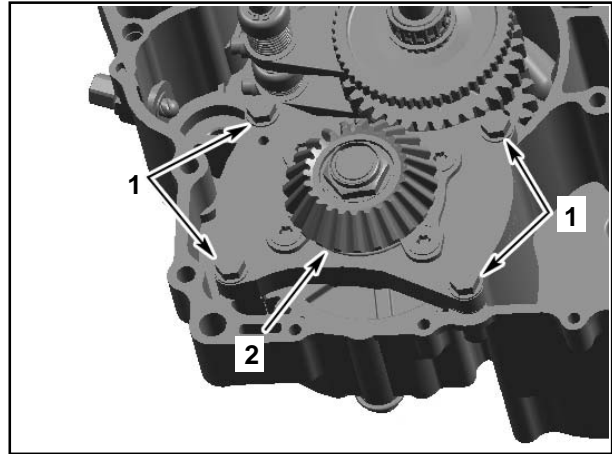

1.Screws
2.Drive Pinion Gear

Place parking lock lever in parking position, then align shift drum tracks with shift forks and fit it in left crankcase. Shift parking lock lever to parking position, then align shift drum axial track with shift fork pin and fit it in the left crankcase.

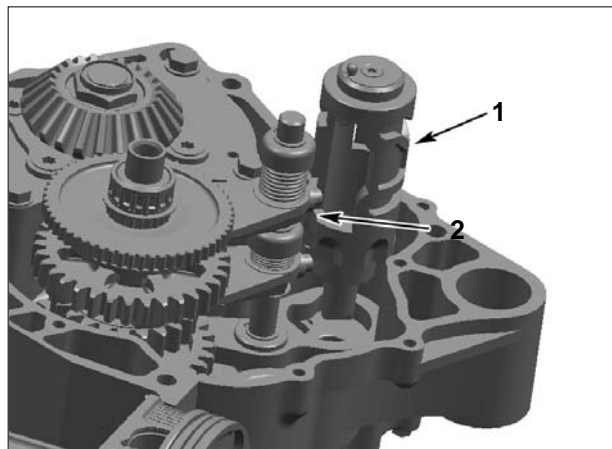

1.Shift Drum
2.Axial Track

Using an appropriate tool, shift to low range, then install gearshift main shaft.

Install washer and low range gear.

Using an appropriate tool, shift to neutral range.

Turn main shaft, check if gears rotate freely and smoothly.

Rotate the main shaft, check if the corresponding meshing gears turn freely and smoothly.

NOTE: When installing rotational parts, equally oil shaft necks.

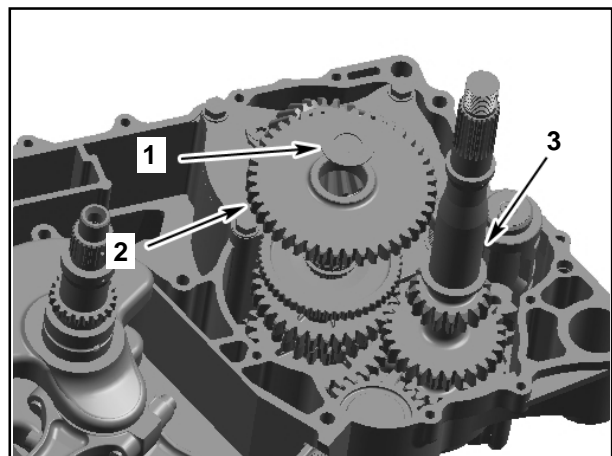

1.Washer
2.Lo Range Gear
3.Main Shaft

Install a new crankcase gasket.

NOTE: Always use a new crankcase after splitting crankcase.

Place the right crankcase on the left crankcase. Install screws and torque to specifications.

WARNING

Do not turn shift drum before shift lever installation is completed.

Install driven shift lever assy and drive shift lever assy.;
Torque driven shift lever screw to specified value;

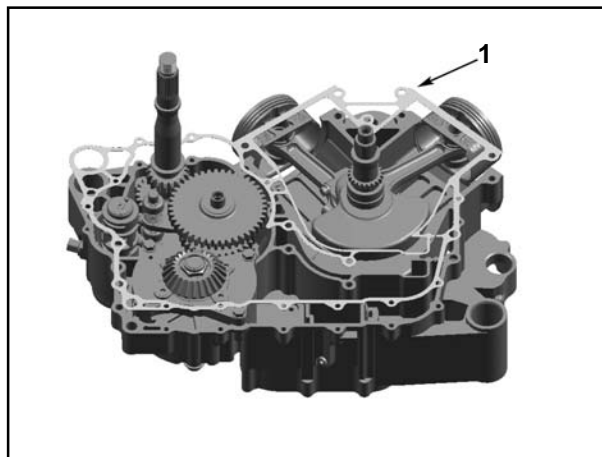

1. Crankcase Gasket

NOTE: When installing driven shift lever assy and drive shift lever assy, the marks on their teeth should be aligned.

Install shift lever cover gasket and cover;
Install shift lever cover screws and torque to specified value;

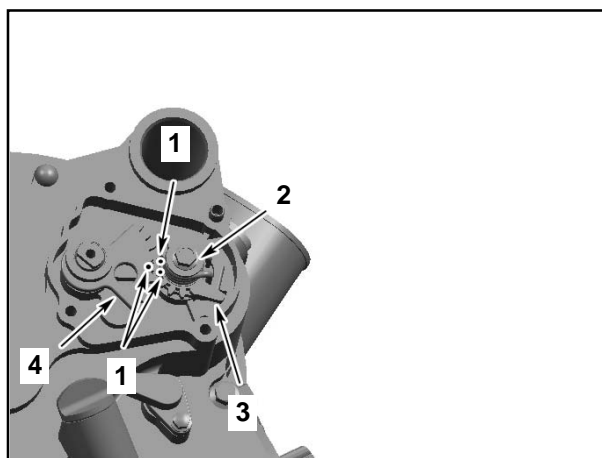

1. Marks
2. Screw
3. Driven Shift Lever Assy
4. Drive Shift Lever Assy

Install other removed parts.

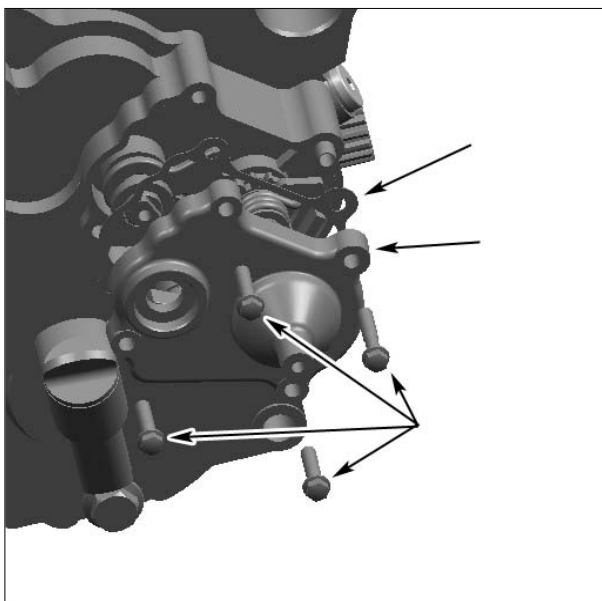

1. Screws
2. Shift Lever Cover
3. Shift Lever Cover Gasket

CVT AND CLUTCH**SERVICE TOOLS**

Decription	P/N	Page
Split tool,drive&driven pulley	0800-052000-922-003	6
Drive pulley oil seal installer	0800-051204-923-001	8
Drive pulley holder	0180-051000-922-001	10
Driven pulley remover	0800-052000-922-002	11
Driven pulley holding wrench	0800-052000-922-001	14
Installer,clutch housing oil seal	0800-013104-923-001	16
Clutch housing damper	0180-053100-921-001	16
Clutch holding wrench	0180-054000-922-001	18

SERVICE PRODUCTS

Decription	P/N	Page
Engine oil		
Threadlocker		
Retaining Compound		

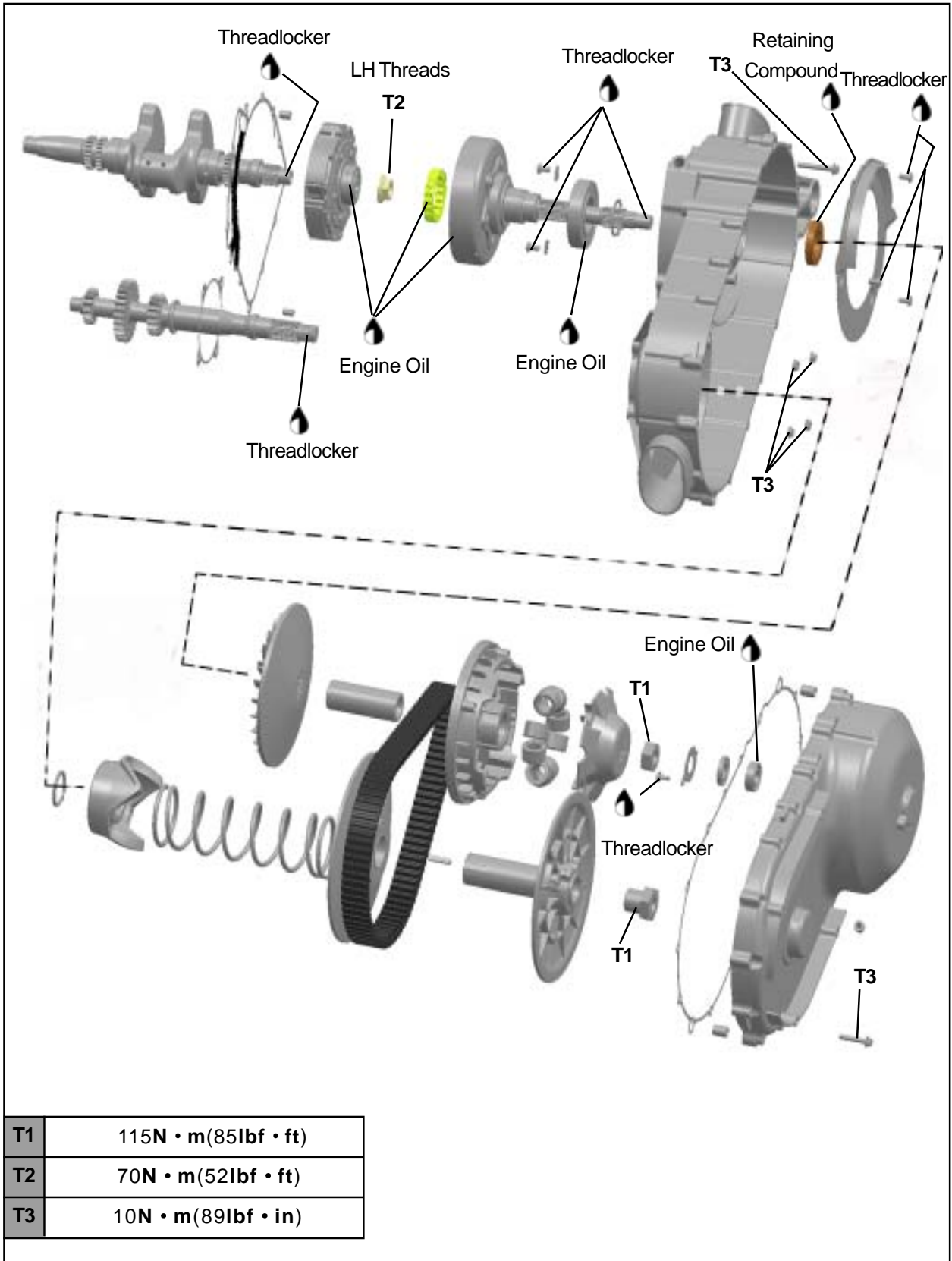

GENERAL

NOTE: For a better understanding, the following illustrations are taken with engine out of vehicle. To perform the following instructions, it is not necessary to remove engine.

During assembly/installation, use the torque values and service products as in the exploded views.

Clean threads before applying a threadlocker. Refer to **LUBRICANTS AND SERVICE PRODUCTS** at the beginning of this manual for complete procedure.

WARNING

Torque wrench tightening specifications must strictly be adhered to. Locking devices (e.g.: locking tabs, elastic stop nuts, cotter pin, etc.) must be replaced with new ones.

WARNING

Never touch CVT while engine is running.
Never drive vehicle when CVT cover is removed.

WARNING

Any drive pulley repairs must be performed by an authorized CFMOTO dealer. Subcomponent installation and assembly tolerances require strict adherence to procedures detailed.

CAUTION: Never use any type of impact wrench at drive pulley removal and installation.

WARNING

The clutch assembly is a precisely balanced unit. Never replace parts with used parts from another clutch assembly.

CAUTION: These pulleys have metric threads. Do not use SAE threads puller. Always tighten pulley by hand to ensure that the drive pulley has the same type of threads (metric vs SAE) prior to fully tightening.

CVT COVER

CVT Cover Removal

Remove CVT cover screws;

Remove CVT cover comp.;

Remove gasket.

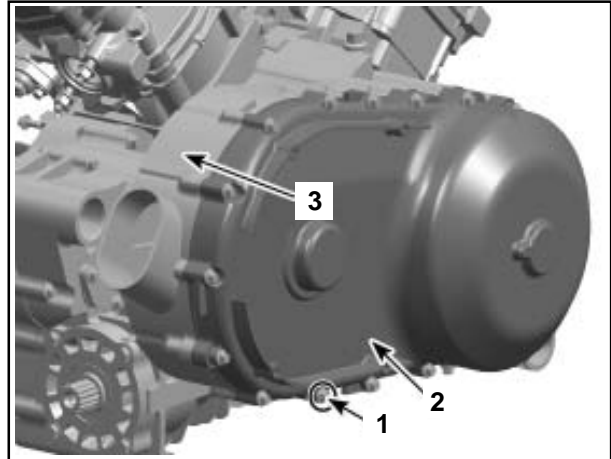

- 1.Screw
- 2.CVT Cover
- 3.CVT Case

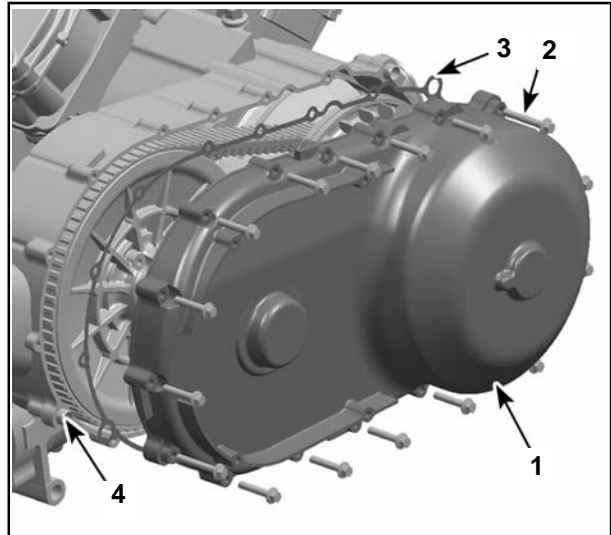

- 1.CVT Cover
- 2.Screw
- 3.Gasket
- 4.Dowel Pin

CVT Cover Inspection

Remove the bolts and retaining plate, then remove oil seal;

Inspect bearing rotating condition. If any damage has been found, replace the bearing;

Apply lubricant oil on bearing outer ring. Use special tool to install the bearing and check it for smoothness;

Apply grease inside bearing;

Use a new seal and apply grease on seal lips.

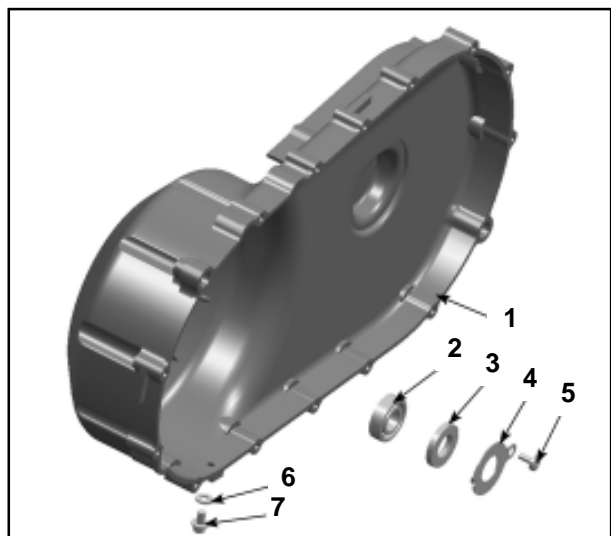

- 1.CVT Cover
- 2.Bearing
- 3.Oil Seal
- 4.Retaining Plate
- 5.Screw
- 6.Washer
- 7.Screw

CVT Cover Installation

Reverse the removal procedure for CVT Cover installation.

NOTE:

Tighten bolts in criss-cross sequence;
Replace new seal;
After Installing oil seal retaining plate, apply threadlocker on screw threads.

DRIVE BELT

Drive Belt Removal

Remove CVT cover and gasket(Refer to *CVT Cover*);

Remove drive pulley (refer to *Drive Pulley*);

Remove driven pulley (refer to *Driven Pulley*);

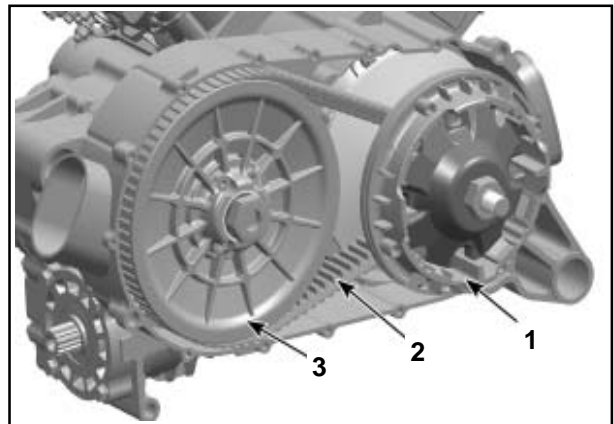

1. Drive Pulley
2. Drive Belt
3. Driven Pulley

NOTE:

If no printed arrow mark has been left on drive belt, remark the belt during removal to avoid incorrect installation.

Drive Belt Inspection

Check belt for cracks, fraying or abnormal wear.
Replace if necessary.
Check drive belt width at cord level.
Replace if it is out of specification.

Belt Width Service Limit: 33.0mm (1.181 in)

Tool: Vernier caliper

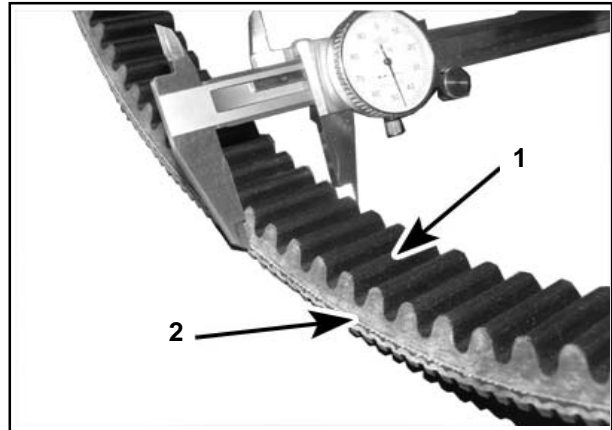

1. Drive Belt
2. Cord in Drive Belt

CAUTION: If belt surface is contaminated with grease or oil, degrease the belt thoroughly.

Drive Belt Installation

Reverse the removal procedure for belt installation.

NOTE:

1. Using special tool, insert the threaded hole of driven pulley and tighten to open the pulley.

2. No grease on belt and drive pulley

3. Arrow printed on belt should point towards the front of vehicle, viewed on top.

If no arrow on belt, install follow removal directly remark.

4. Primary sheave should install correctly to avoid belt against other parts and not well installed.

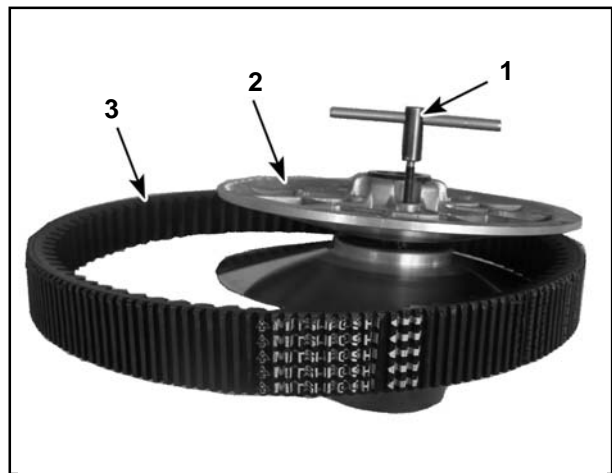

1. Special Tool
2. Driven Pulley
3. Drive Belt

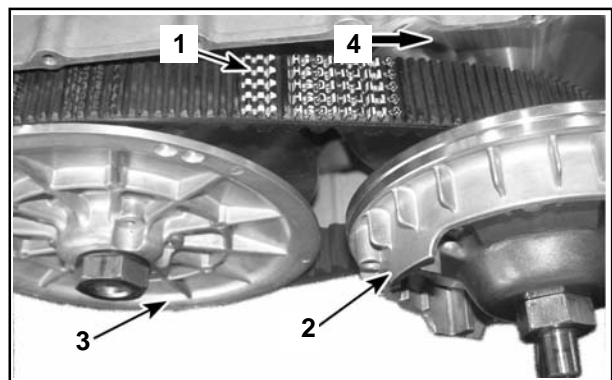

1. Printed Mark on Drive Belt
2. Drive Pulley(Front)
3. Driven Pulley(Rear)
4. Rotation Direction

DRIVE PULLEY

Drive Pulley Removal

Remove CVT Cover no.2 (refer to **CVT Cover**);
 Remove drive pulley nut no.4 and drive pulley sliding sheave no.6;
 Remove driven pulley nut no.3 and driven pulley no.5;
 Remove drive belt(refer to **Drive Belt**);
 Remove drive pulley fixed sheave;

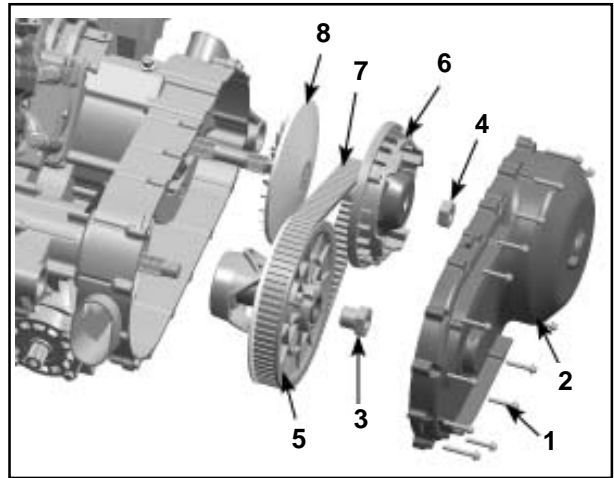

1.CVT Cover Screw 2.CVT Cover
 3.Driven Pulley Nut 4.Drive Pulley Nut
 5.Driven Pulley 6.Drive Pulley Sliding Sheave
 7.Drive Belt 8.Drive Pulley Fixed Sheave

Drive Pulley Disassembly

Remove drive pulley shaft sleeve;
 Remove cam and rollers;

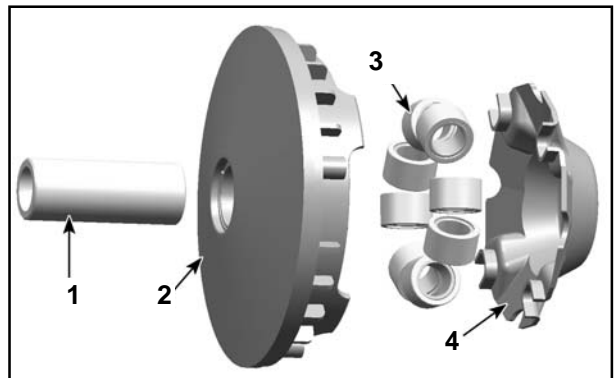

1.Sleeve 2.Drive Pulley Sliding Sheave
 3.Roller 4.Cam

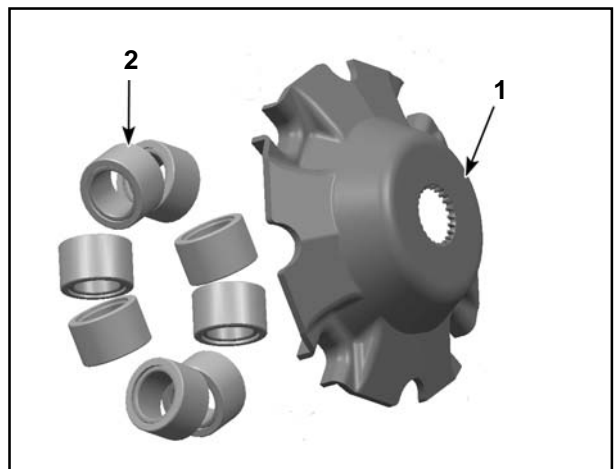

1.Cam
 2.Roller

Cam, Sliders and Rollers Inspection

Check Cam for wear and other damages. Replace if necessary.

Check slider wear and other damages. Replace if necessary.

Check each roller and sliding surface for wear and other damages, if any damage has been found, replace all rollers.

NOTE: *Whenever replacing rollers and sliders, always replace all rollers and sliders at the same time, or unbalanced drive pulley will occur because of rollers or sliders difference.*

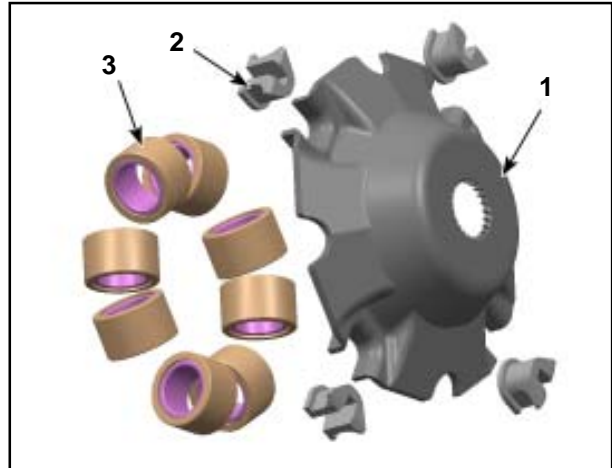

- 1. Cam
- 2. Slider
- 3. Roller

Oil Seal Inspection

NOTE: *If no oil seal inside, It's not necessary to perform this procedure.*

Check oil seal lip for wear and other damages. Replace if necessary.

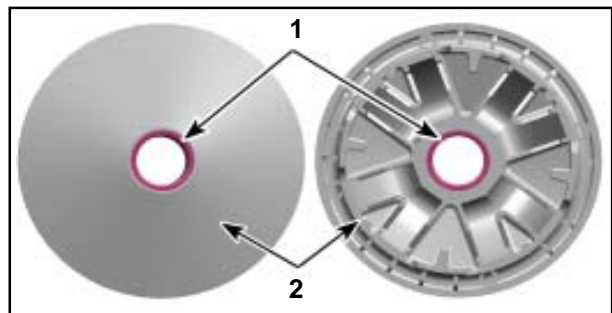

- 1. Oil Seal
- 2. Drive Pulley Sliding Sheave

Special tool is required to install the oil seal.

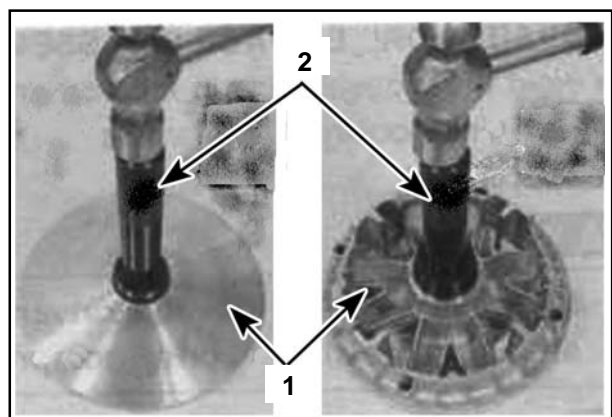

- 1. Drive Pulley Sliding Sheave
- 2. Special Tool

Primary sliding sheave and fixed sheave Inspection

Check drive pulley faces for abnormal conditions. If any wear and damage has been found, replace it.

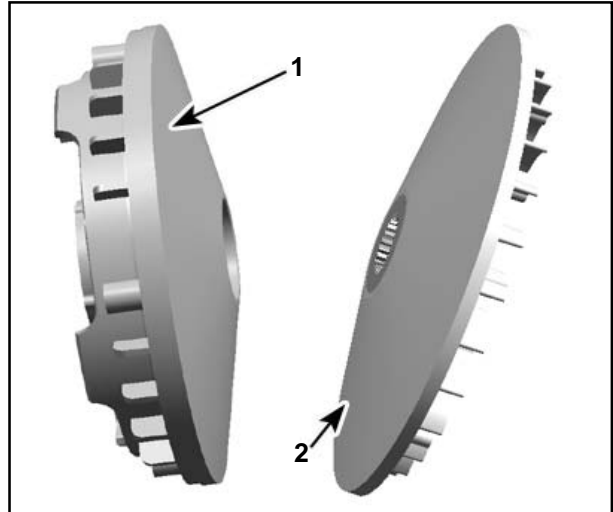

1. Drive Pulley Sliding Sheave

2. Drive Pulley Fixed Sheave

Drive Pulley Sliding Sheave Installation

Install 8 rollers into sliding sheave;

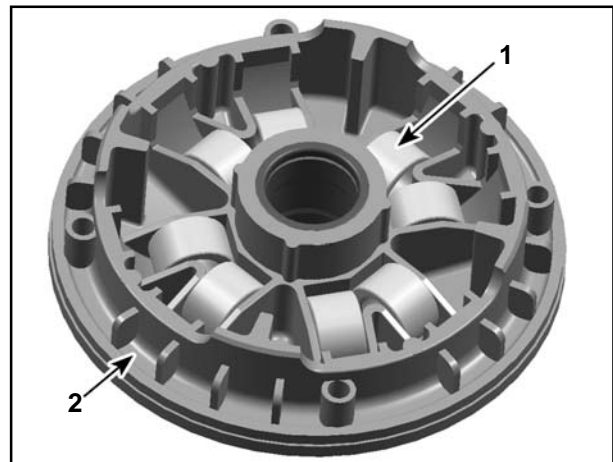

1. Roller

2. Drive Pulley Sliding Sheave

Install 4 sliders on cam;

Install cam on sliding sheave;

Install shaft sleeve into sliding sheave.

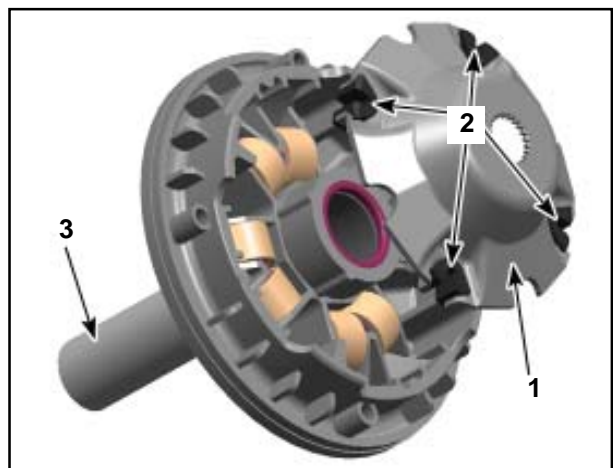

1. Cam

2. Slider

3. Drive Pulley Shaft Sleeve

NOTE: When installing shaft sleeve, hold the cam to avoid rollers coming out of place.

Drive Pulley Installation

Reverse the removal procedure for installation

NOTE:

1.If oil seal is inside the hole, apply grease inside the hole and oil seal lip

2.If belt surface is stained with grease or oil, degrease the belt thoroughly.

3.Using sepecial tool,tighten the drive pulley nut to specified torque:

Drive Pulley Nut Tightening Torque:115N.m

Special tool:Drive Pulley Holder

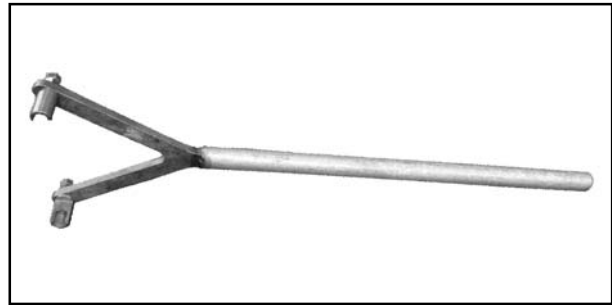

CVT Drive Pulley Holder

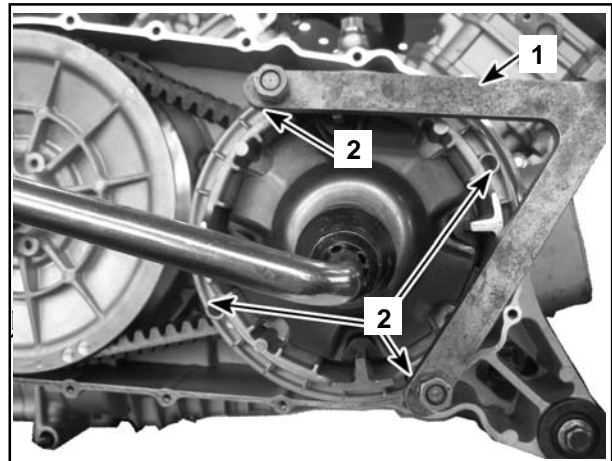

1.Drive Pulley Holder

2.Locations to Place Drive Pulley Holder

DRIVEN PULLEY

Removal

Remove CVT case(refer to **CVT COVER**);

Remove drive pulley nut(refer to **DRIVE PULLEY**);

Remove driven pulley nut and driven pulley;

Remove drive belt(refer to **DRIVE BELT**);

Remove driven pulley;

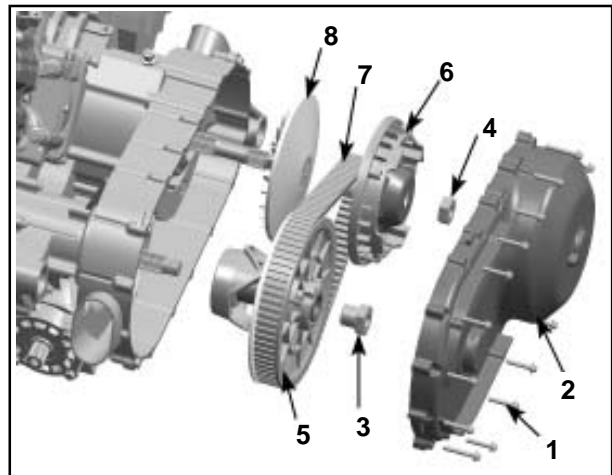

1.CVT Cover Bolt 2.CVT Cover

3.Driven Pulley Nut 4.Driven Pulley Nut

5.Driven Pulley 6.Drive Pulley

7.Drive Belt 8.Drive pulley Fixed Sheave

DRIVEN PULLEY

Disassembly

NOTE:

Before disassembly, mark on the spring installation holes and cam feet to sliders positions.

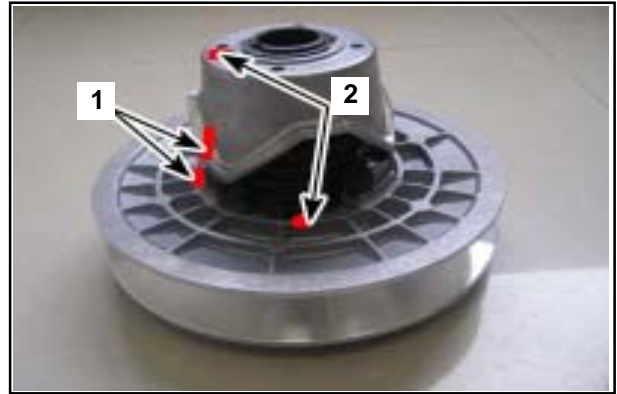

1. Cam and slider marks
2. Spring Installation Holes Marks

As the illustration shows, place driven pulley on the special tool base.

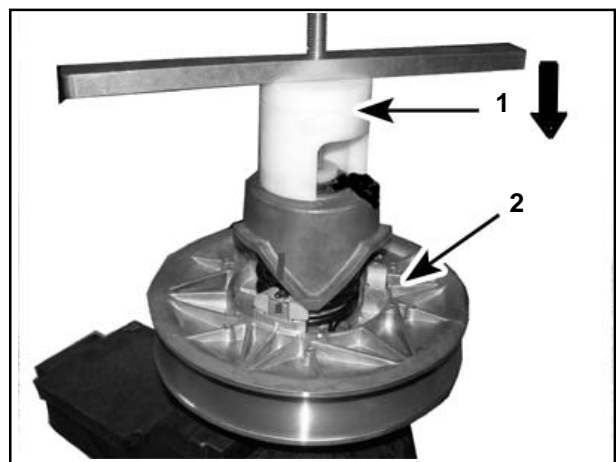

1. Driven Pulley Remover
2. Driven Pulley

Turn special tool handle to compress the cam and spring. Using a circlip remover (a plier), remove circlip.

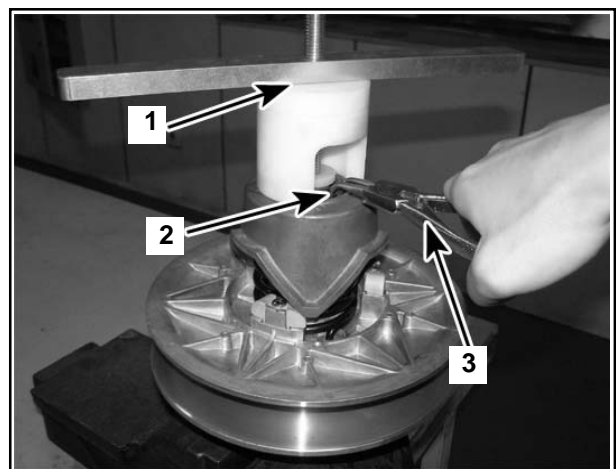

1. Driven Pulley Remover
2. Circlip
3. Circlip Remover

Slowly loosen tool handle to release the spring tension and remove the special tool;
Remove cam;
Remove guide pin;
Remove spring and sliding sheave of driven pulley.

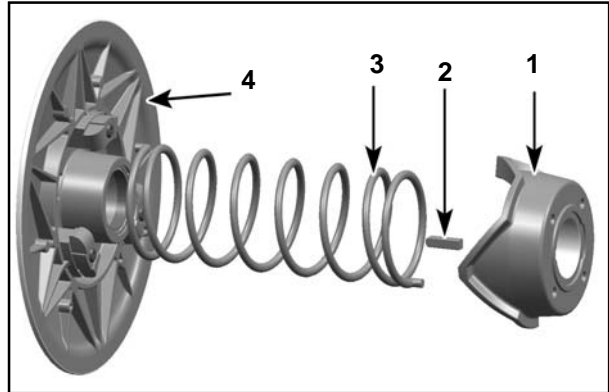
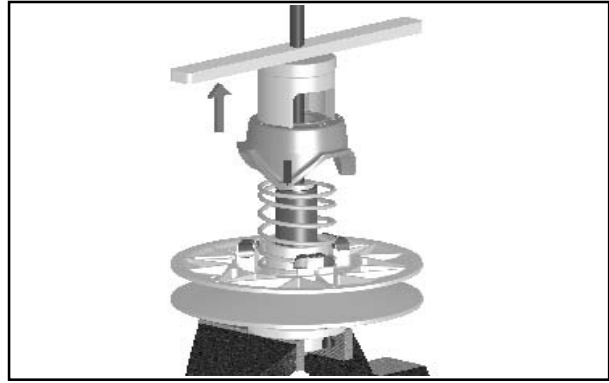

1. Cam
2. Guide Pin
3. Spring
4. Sliding Sheave of Driven Pulley

Driven Pulley Inspection

Driven Pulley Fixed Sheave Inspection

Check driven pulley faces for any abnormal conditions, such as heavy wear or visible damage. Replace if necessary.

NOTE: Clean fixed sheave of driven pulley before inspection.

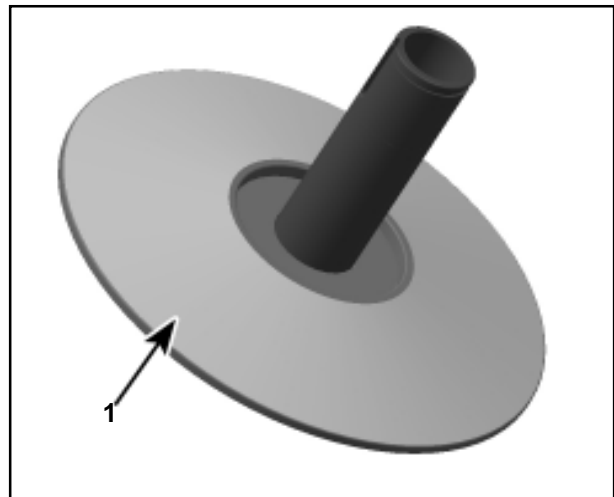

1. Drive Face of Fixed Sheave

NOTE: Driven pulley assembly is precisely matched. If only fixed sheave or sliding sheave is replaced, the vibration may increase. It's recommended to replace both when necessary.

Driven Pulley Sliding Sheave Inspection

Inspect the drive face of sliding sheave for heavy wear and damage. Replace if necessary.

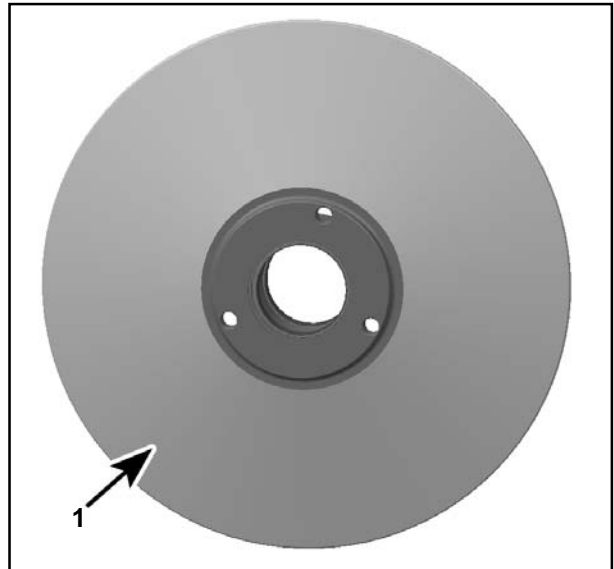

1. Drive Face of Sliding Sheave

Inspect the 4 sliders on driven pulley for wear and other damages. If the worn thickness is over the measurement illustrated in the following figure, replace all 4 sliders at the same time.

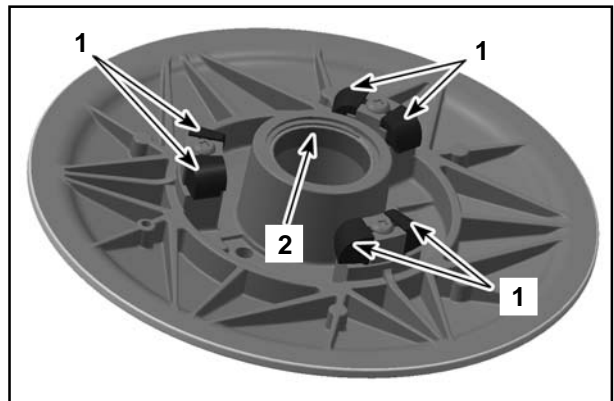

1. Slider
2. Sliding Sleeve

NOTE: Clean the sliding sheave before inspection.

$A \geq 1.5\text{mm}$

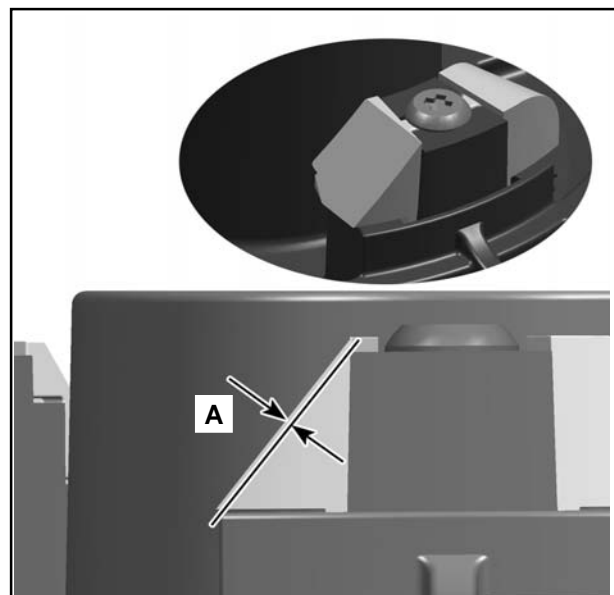

Cam Inspection

Check spring cam sliding face for wear and other damages. replace if necessary.

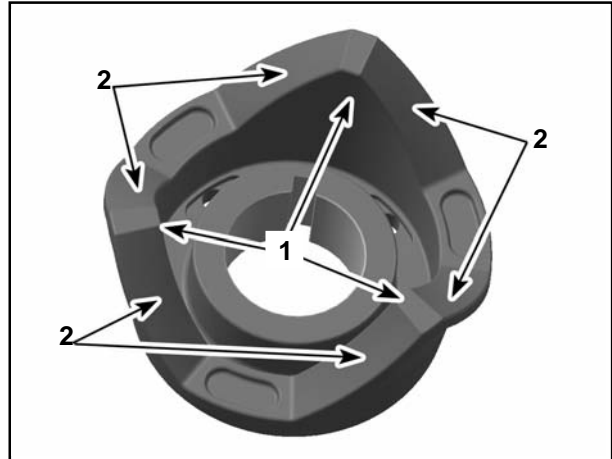

1.Cam
2.Sliding Face

Driven Pulley Spring Inspection

Check spring free length. If it is shorter than limit length, replace it.

Spring free limit length A:214.0mm.

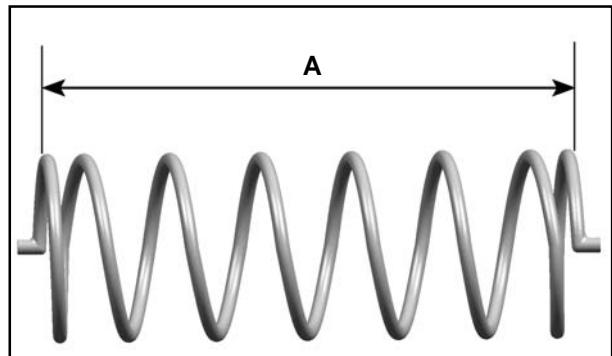

1.Spring

Driven Pulley Assembly

Reverse the disassembly procedure for driven pulley assembly.

NOTE: *Special tool is also required in driven pulley assembly.*

Driven Pulley Installation

Reverse the removal procedure for driven pulley installation.

NOTE:

*Torque driven pulley nut to specified value.
Driven Pulley Nut Tightening Torque:115N.m.*

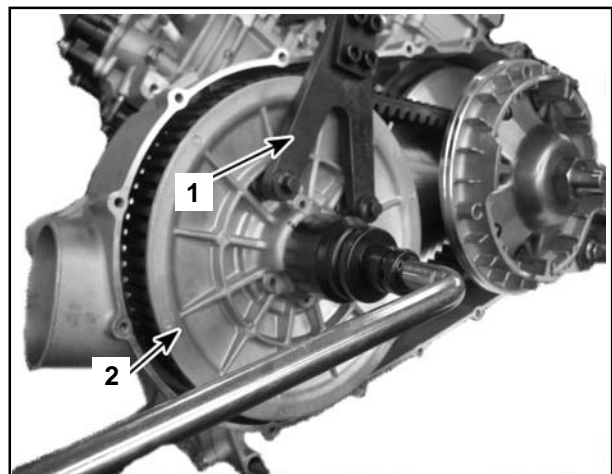

1.CVT Driven Pulley Holder

CVT AIR GUIDE

CVT Air Guide Removal

Remove CVT cover(refer to **CVT COVER**);

Remove drive pulley(refer to **DRIVE PULLEY**)

Remove driven pulley(refer to **DRIVEN PULLEY**);

Remove drive belt(refer to **DRIVE BELT**);

Remove air guide plate;

Remove CVT case screws and nuts;

Remove clutch housing and CVT Case;

Remove dowel pin(or not) and gaskets;

Remove one-way clutch.

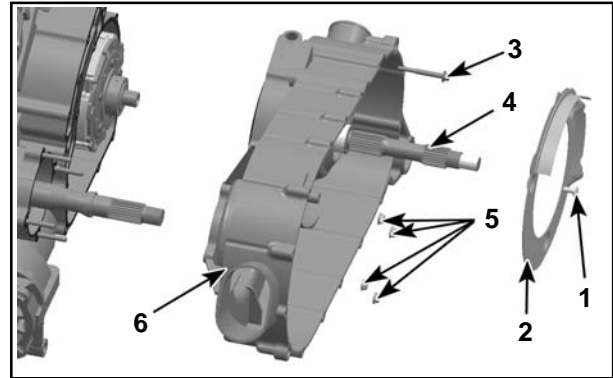

1.Screws 2.Air Guide Plate
3.Screw 4.Clutch Housing
5.Nut 6.Air Guide

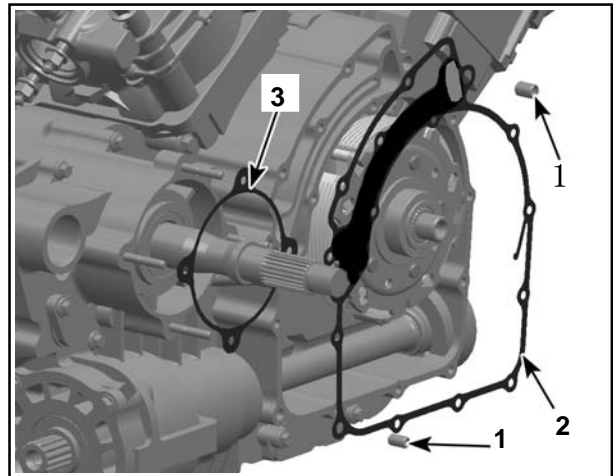

1.Dowel Pin
2.Gasket(front)
3.Gasket(rear)

Clutch Housing Disassembly

Remove oil seal;

Remove retaining ring;

Use press machine to press clutch housing out of CVT air guide.

NOTE: *If bearing or oil seal is not suspected to be damaged, it's not necessary to perform the disassembly procedure.*

CVT Air Guide and Clutch Inspection

Check bearing for rotation condition, if any abnormal condition has been found, remove bolt and bearing plate to replace the bearing.

Check oil seal, if any damage has been found, replace it;

Check one-way clutch for wear and damage. Replace if necessary;

Check clutch housing inner side if color changes into blue and for scratches, cracks or uneven wear, if serious damage has been found, replace it.

NOTE: *If bearing is checked to be ok, it's not necessary to replace it. However, whenever disassembling clutch housing, oil seal must be replaced.*

CVT Air Guide and Clutch Housing Assembly

Apply grease on bearing and install it in place by special tool. Check the rotation condition;

Install CVT bearing plate and screws;

Using hydraulic press machine and special press tool, install the clutch housing into CVT air guide.

NOTE: *When pressing clutch housing, it's required to put a special holding tool on clutch shaft end to support bearing inner ring.*

Apply grease on oil seal lip and install it with a special tool;

Install one-way clutch into clutch housing;

NOTE: *The marked side of one-way clutch should point outside.*

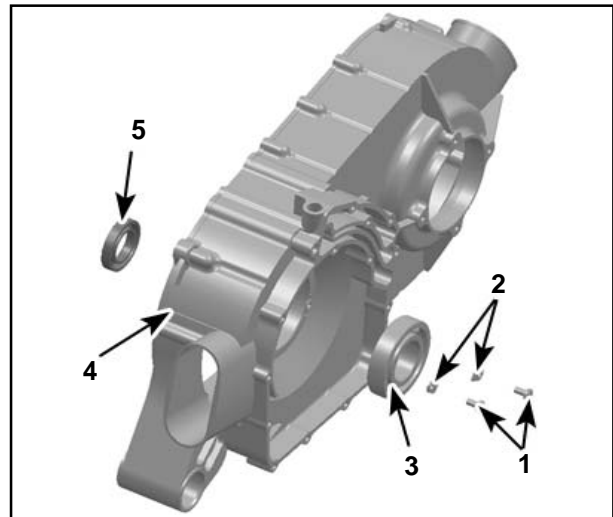

1. Screws 2. Bearing Plate
3. Bearing 4. CVT Air Guide
5. Oil Seal

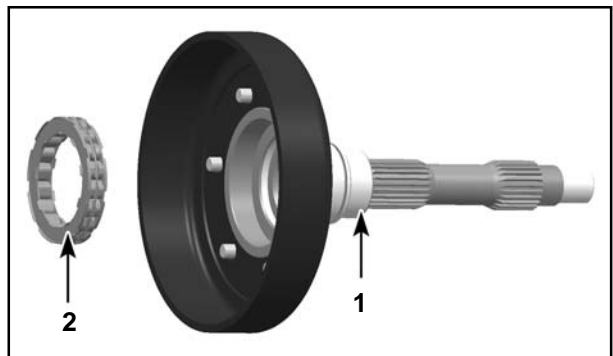

1. One-way Clutch
2. Clutch Housing

CVT Air Guide and Clutch Housing Installation

Reverse the removal procedure for CVT air guide and clutch housing installation.

NOTE:

1. Use new front and rear gasket. Keep them even on bases .
2. Fasten screws/nuts in criss-cross sequence.

CLUTCH Removal

Remove CVT cover (refer to **CVT COVER**);

Remove drive pulley (refer to **DRIVE PULLEY**);

Remove driven pulley (refer to **DRIVEN PULLEY**);

Remove drive belt (refer to **DRIVE BELT**);

Remove CVT air guide and clutch housing (refer to **CVT AIR GUIDE and CLUTCH HOUSING**);

Use special tool to remove clutch nut and remove clutch.

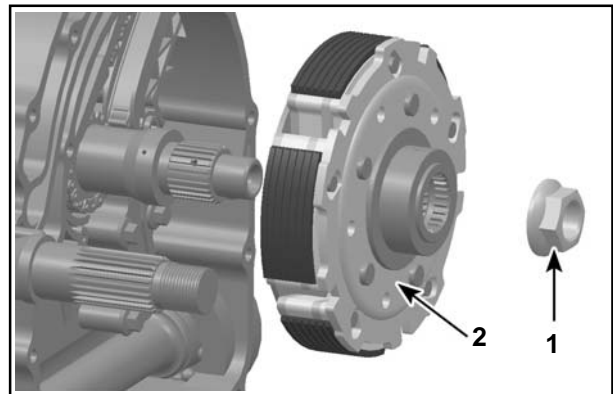

1. Clutch Nut

2. Clutch

NOTE: Clutch nut threads is left hand oriented.

Clutch Inspection

Check clutch for debris, scratches, uneven wear and discoloration. Meanwhile, check clutch shoe depth, if no groove remains on any brake shoe, replace the clutch.

Check one-way clutch for wear, if any damage has been found, replace it.

NOTE: *Clutch must be replaced as an assembly.*

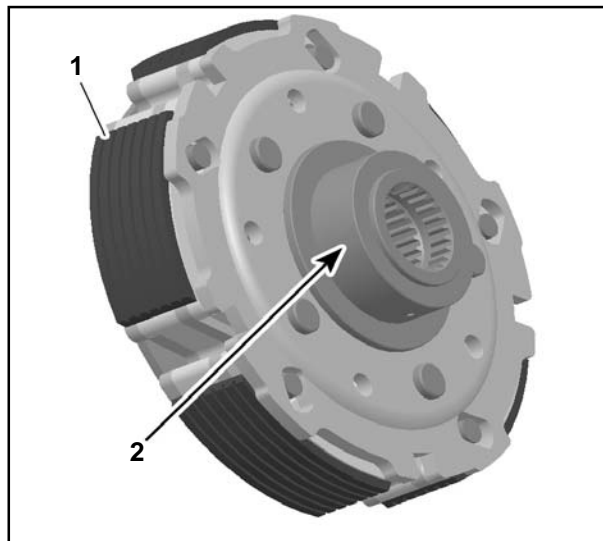

1. Clutch Shoe
2. Clutch Collar

Clutch Installation

Reverse the removal procedure for clutch installation.

Use special tool to hold clutch and then tighten nut.

NOTE: *Apply threadlocker on nut threads. Torque it to specified torque value. The threads are left hand oriented.*

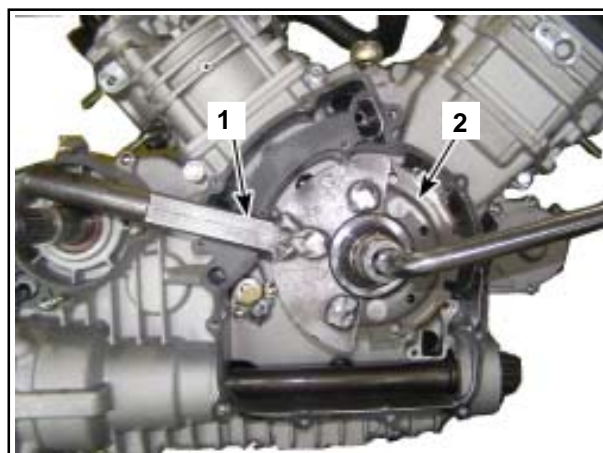

1. Clutch Holding Tool
2. Clutch

Nut tightening Torque Value: 105N • m.

ENGINE LUBRICATION SYSTEM

SERVICE TOOLS

Description	P/N	Page
Oil Pressure Gauge		6
Adapter Hose		6

SERVICE PRODUCTS

Description	P/N	Page
Engine Oil		
Threadlocker		

COMPONENTS

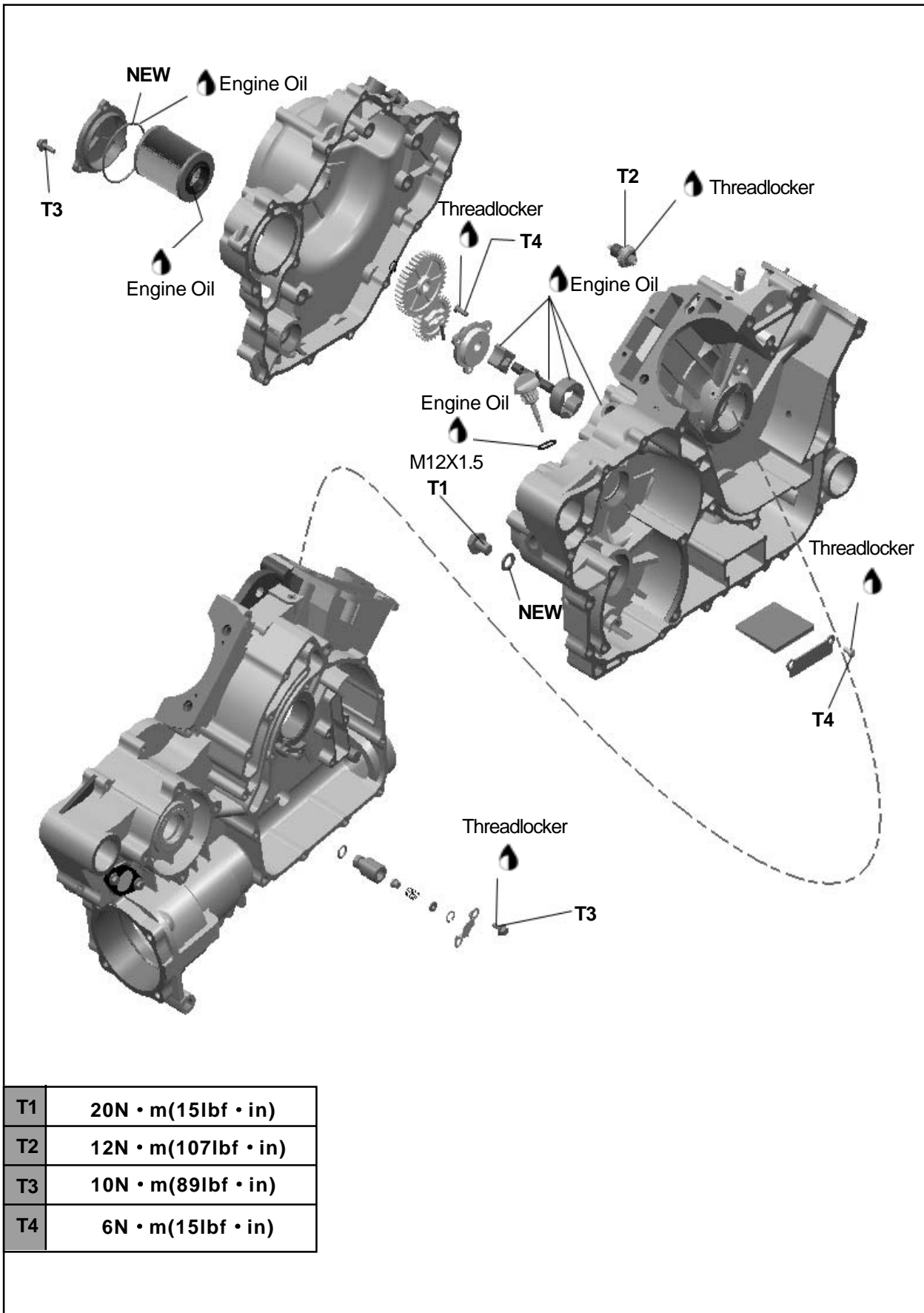

ENGINE LUBRICATION

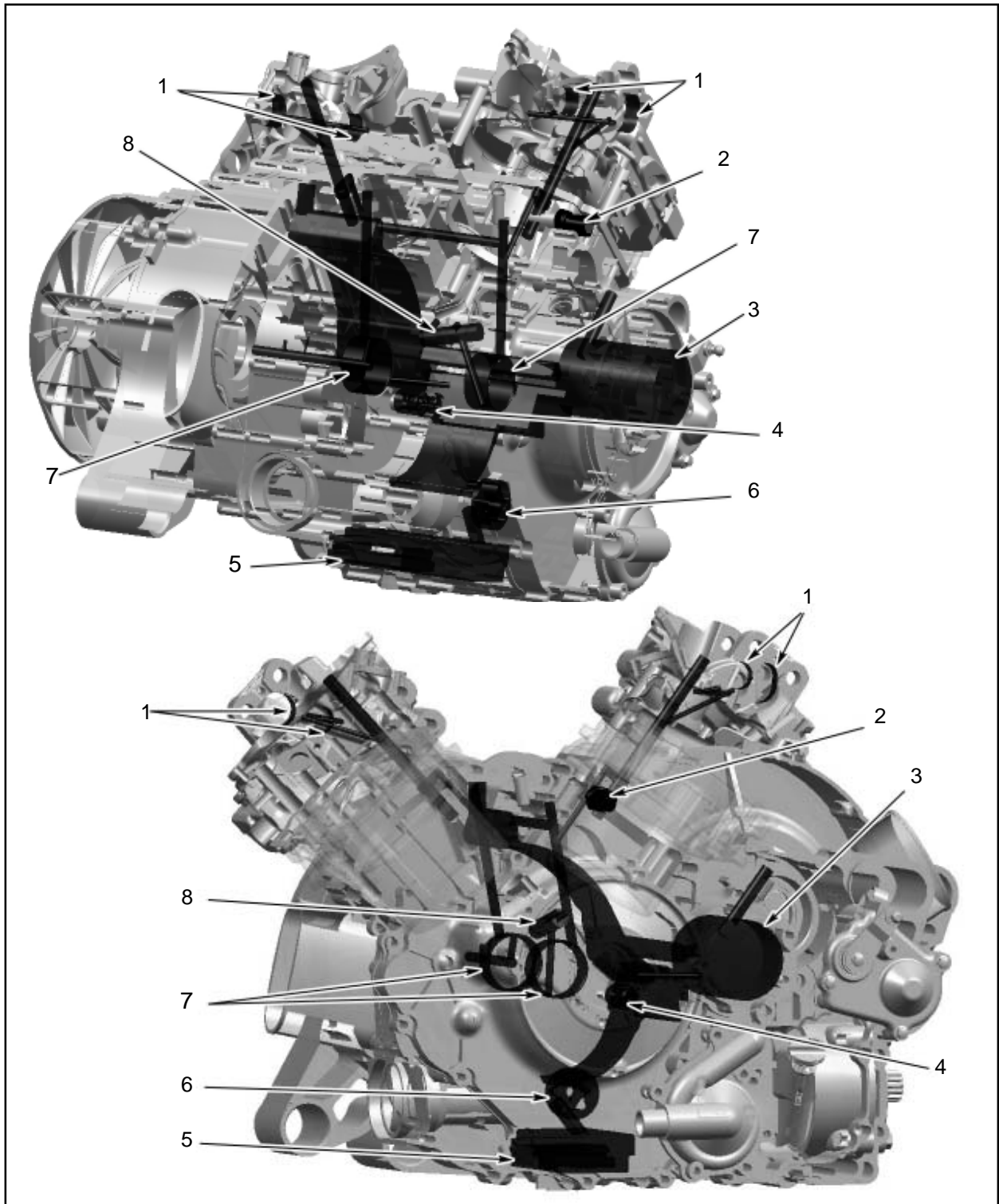

1. Camshaft Bearings

2. Oil Pressure Switch

3. Oil Filter

4. Oil Pressure Regulator Valve

5. Oil Strainer

6. Oil Pump

7. Crankshaft Main Bearings

8. Connecting Rod Bearing

GENERAL

Lubrication is employed to reduce the wear of some components, such as piston, crankshaft, camshaft, etc, which moves relative against other parts. Proper lubrication is the basis for engine normal operation.

Recommended engine oil is required for this engine. Engine oil has cleaning, anti-rust, sealing, cooling and other functions besides lubrication.

WARNING

Torque wrench must be used when tightening. Locking devices (e.g.: locking tabs, elastic stop nuts, cotter pin, etc.) must be replaced with new ones.

Engine Oil Level Check

Start the engine and allow it to idle for a few minutes, then shut it off. Wait a few minutes to allow oil flow down to crankcase then check oil level;

Ensure vehicle is on a level surface;

Unscrew dipstick and wipe the oil residue off, then put dipstick in the hole. Don't screw in dipstick to read oil level, just make dipstick threads contact the hole surface;

Remove dipstick and read oil level;

Engine oil level must be between "upper" and "lower" marks;

If oil level is below "lower", refill.

NOTE:

Strictly follow the procedure above, otherwise wrong oil level may be indicated;

Vehicle must be placed on a level surface;

Don't screw in dipstick to read oil level.

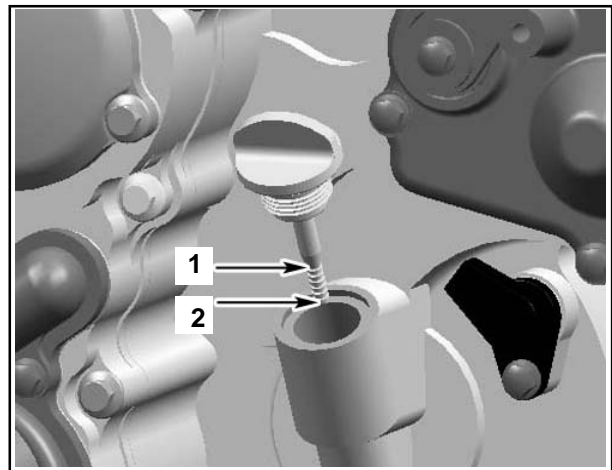

Oil Level Mark: 1.Upper 2.Lower

Engine Oil Change

Replace engine oil and filter element at the same time when engine is warm.

WARNING

The engine oil can be very hot. Wait until engine oil is warm.

Place a drain pan under the engine oil drain plug area;

Clean the drain plug area;

Unscrew oil dipstick, drain plug and discard the gasket ring;

Allow oil to drain completely from crankcase;

Install washer and drain plug;

Drain plug tightening torque: $20\text{N} \cdot \text{m}$

Replace oil filter element, refer to **OIL FILTER** further in this section;

Refill engine with about 3.4 L recommended engine oil through dipstick hole;

Install dipstick. Run the engine to ensure oil filter and drain plug areas are not leaking;

After filling, check engine oil level with dipstick.

Refer to **Engine Oil Level Check** above.

NOTE:

*Oil condition gives information about the engine condition. See **TROUBLESHOOTING** section. Check the drained engine oil for engine shavings and residue. Presence of debris indicates a failure inside the engine. Check engine to correct the problem.*

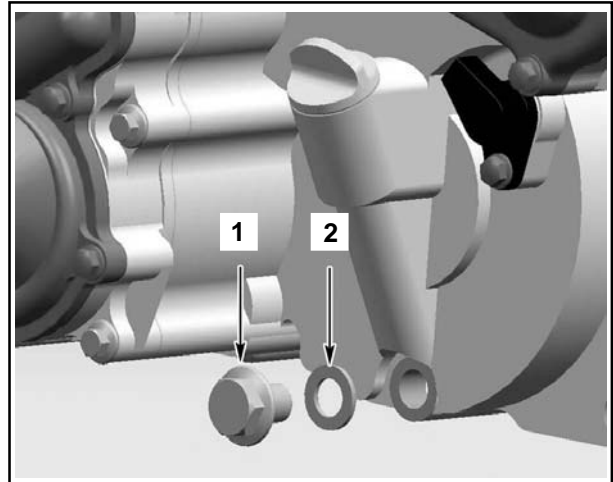

1. Drain Plug

2. Washer

ENGINE OIL PRESSURE

The engine oil pressure test should be done with a warm engine 90°C (194°F) and the recommended engine oil.

Remove engine oil pressure switch;

Install engine oil pressure gauge and adapter hose.

The engine oil pressure should be within the following values:

Oil Pressure	1250 RPM	6000RPM
Minimal	70 KPa	350 KPa
Nominal	180 KPa	420 KPa
Maximal	300 KPa	550 KPa

If the engine oil is out of specifications, check the points described in **THROUBLESHOOTING** section.

Remove engine oil pressure gauge and adapter hose.

Reinstall the engine oil pressure switch.

NOTE: To remove adapter hose from engine oil pressure gauge, use the service tool.



Engine Oil Pressure Gauge



Adapter Hose

OIL FILTER ELEMENT

Removal

Remove oil filter cover screws;

Remove oil filter cover;

Remove o-ring;

Remove oil filter element.

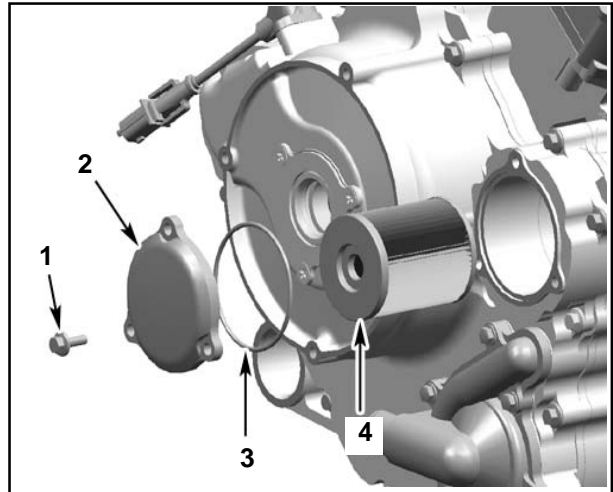

1. Screw
2. Oil Filter Cover
3. O-ring
4. Oil Filter Element

Oil Filter Element Inspection

Check and clean the engine oil filter inlet and outlet area for dirt and other contaminations.

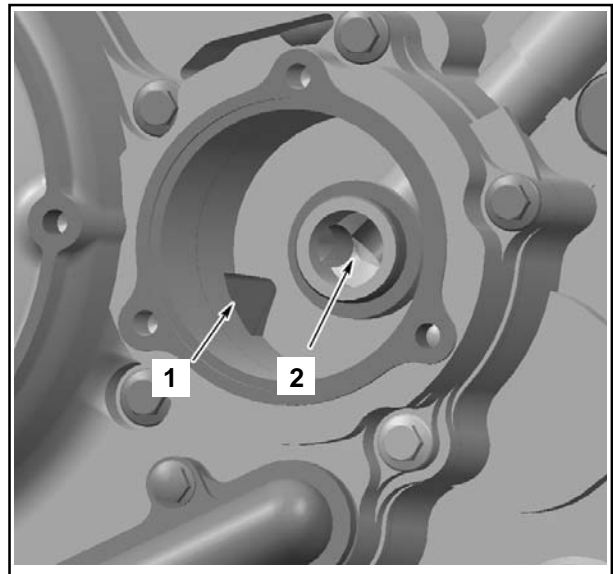

1. Inlet bore from the oil pump to the oil pump
2. Outlet to the engine oil providing system

Oil Filter Element Installation

Install a **NEW** o-ring on oil filter cover;

Apply engine oil on o-ring and the end of filter;

Install the element into oil filter bore;

Install the oil filter cover on the engine.

Torque screws to 10N • m(89lbf • in).

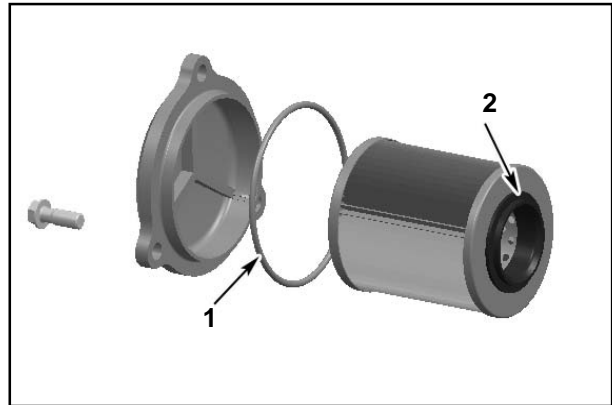

1. Apply a light coating of oil here

2. Apply a light coating of oil here

OIL PRESSURE REGULATOR VALVE

Engine oil pressure valve is located on engine PTO side(under CVT air guide).

The oil pressure regulator valve works when the oil pressure exceeds 450kPa(65PSI).

Removal

Remove screws no.1 and the holding strip;

Remove oil pressure regulator valve.

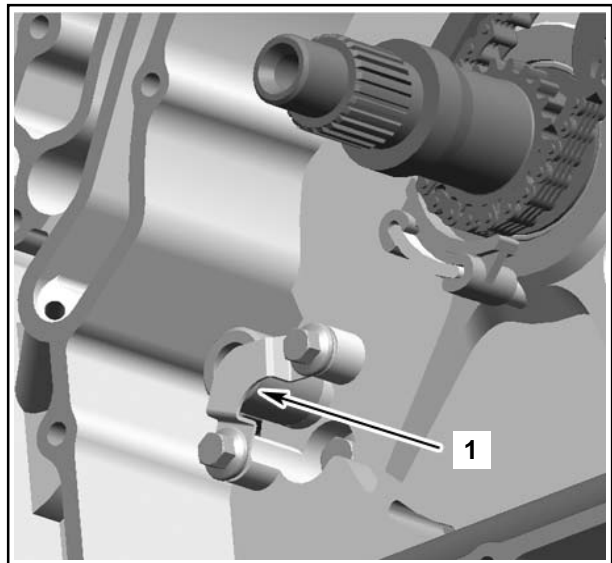

1. Engine Oil Pressure Regulator Valve

Inspection

Inspect oil pressure regulator valve no.4, spring seat no.5, plunger no.7, o-ring no.8 for damages. Replace if necessary. Circlip no.3 must be replaced. Check spring no.6 for free length. If the length is out of the following values, replace it.

Spring Free Length	
New Nominal	17mm
Service Limit	16mm

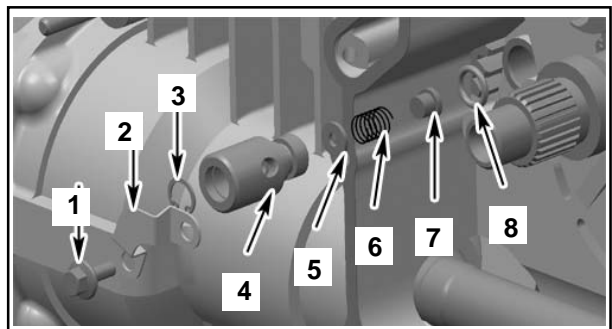

1. Bolt 2. Holding Strip 3. Circlip

4. Oil Pressure Regulator Valve

5. Spring Seat 6. Spring

7. Oil Plunger 8. O-ring

Installation

Reverse the removal procedure for installation.

OIL PUMP

Oil pump is located on the engine MAG side(under magneto cover).

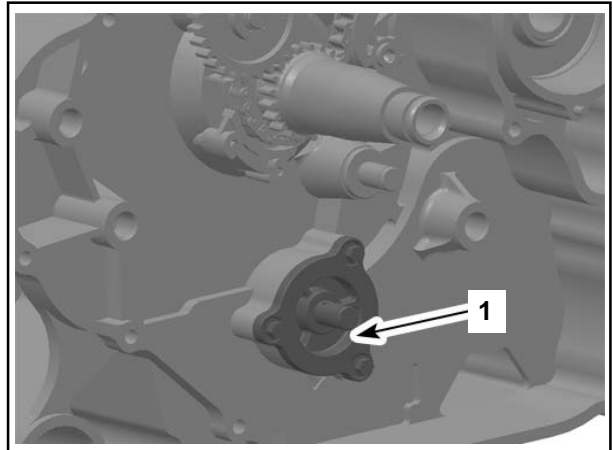

1. Oil Pump

Removal

Remove magneto cover and related parts(see **Magneto Cover Removal**);

Remove magneto rotor(see **Rotor Removal**);

Remove circlip, oil pump gear, needle pin, thrust washer in turn;

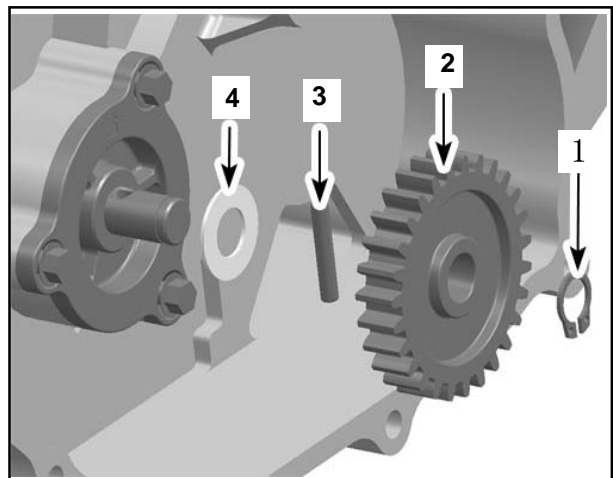

1. Circlip 2. Oil Pump Gear
3. Needle Pin 4. Thrust Washer

Remove oil pump cover screws and oil pump cover;

Remove pump shaft with inner rotor and outer rotor.

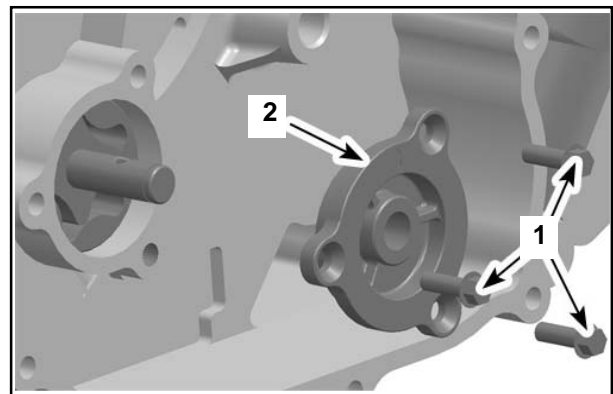

1. Screws 2. Oil Pump Cover

Inspection

Inspect oil pump for marks or other damages. Check for scratches in crankcase between outer rotor and oil pump bore. If so, replace damaged parts;

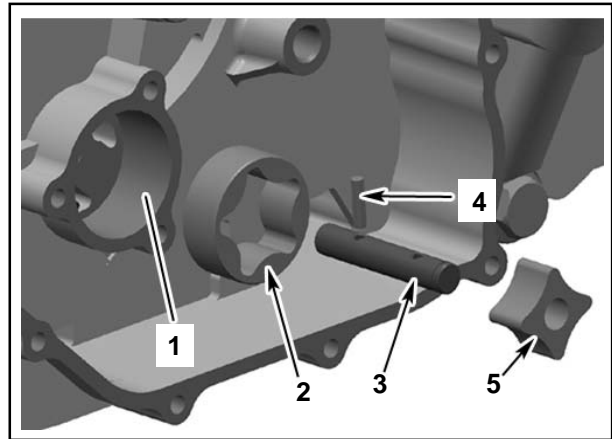

1. Oil Pump Bore 2. Outer Rotor
3. Oil Pump Shaft 4. Needle Pin
5. Inner Rotor

Check inner rotor for corrosion pin holes or other damages. If so, replace oil pump shaft assembly.

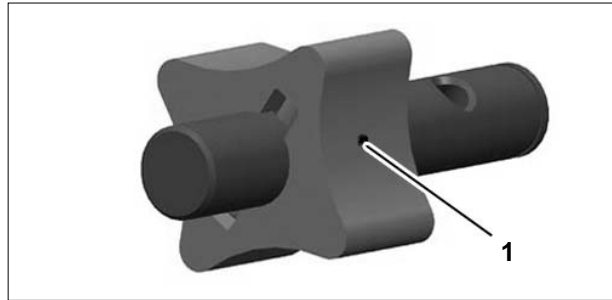

1. Pittings on the teeth

Using a feeler gauge, measure the clearance of inner and outer rotors plus the clearance between outer rotor and oil pump bore as shown.

If clearance between inner rotor and outer rotor exceeds the tolerance, replace the inner and outer rotor.

Ensure to also check oil pump cover, if damaged, replace the oil pump cover.

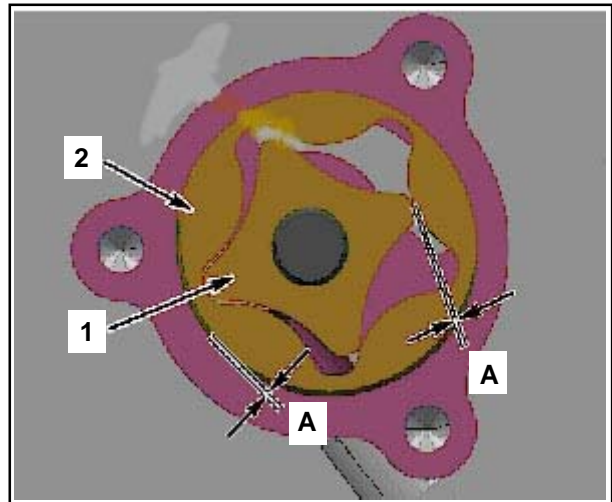

1. Inner Rotor 2. Outer Rotor
A. Service Limit: 0.25mm

If clearance between outer rotor and its bore in crankcase exceeds the tolerance, replace outer rotor assembly and/or crankcase.

Using a depth gauge, measure the axial clearance of the oil pump as shown. Difference between measurements should not exceed 0.1mm(0.008in). If so, replace the inner and outer rotor.



Measurement "A"

Using a depth gauge, measure the axial depth of the part that extends to oil pump bore as shown.

$$A-B \leq 0.2\text{mm}$$

NOTE: When the axial clearance of the oil pump shaft assembly increases, the oil pressure decreases.

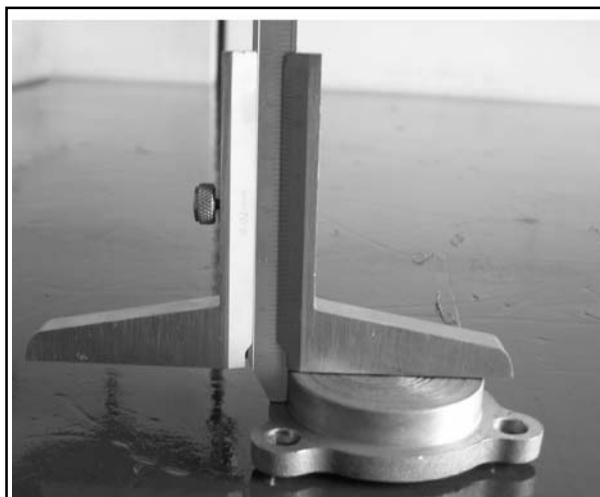

Measurement "B"

Installation

Reverse the removal procedure for installation.

NOTE: No marks on inner and outer rotor. When installing outer rotor, no specified direction for outer rotor.

After installation, check for smooth operation of the oil pump assembly.

Final Test

After engine is completely reassembled, start engine and make sure oil pressure is within specifications (refer to Engine Oil Pressure above.)

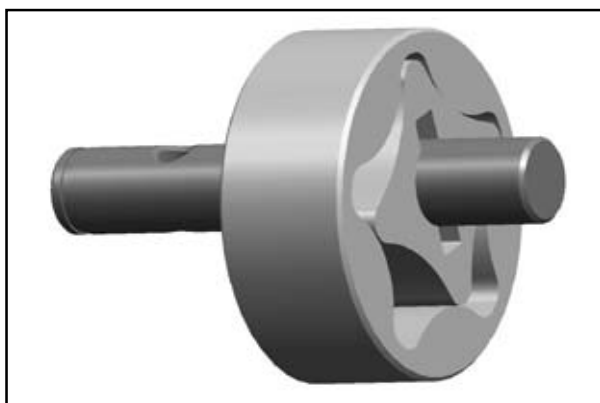

ENGINE OIL STRAINER

The engine oil strainer no.7 is located on the bottom of left crankcase half.

Removal

Refer to Chapter 8.

Cleaning and Inspection

Clean engine oil strainer with a part cleaner then use an air gun to dry it.

WARNING

Always wear eye protector. Chemicals can cause a rash break out and injure your eyes.

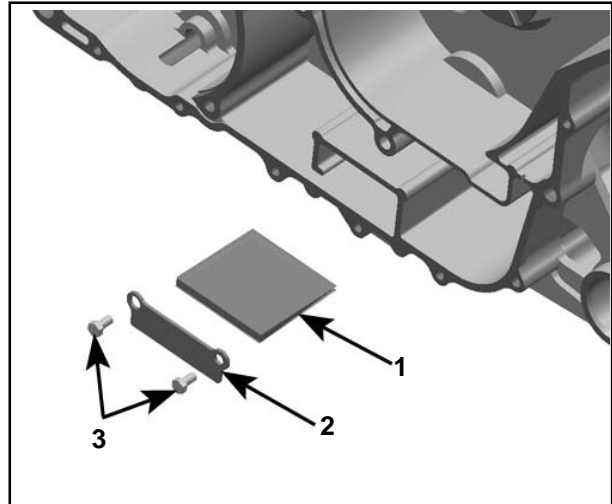

1. Oil Strainer
2. Retaining Plate
3. Screws

Installation

Reverse the removal procedure for installation.

OIL DELIVERY PIPE AND OIL RADIATOR

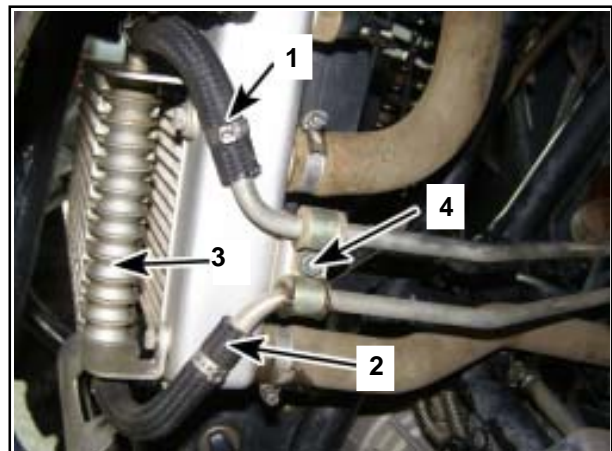
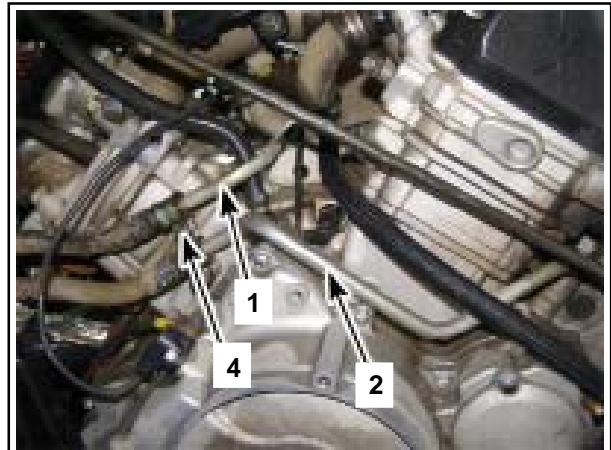

1. Inlet Oil Delivery Pipe
2. Outlet oil Delivery Pipe
3. Oil Radiator
4. Oil Delivery Pipe Holding Screw

Removal

Remove engine inlet and outlet oil delivery pipe retaining screws;
Remove engine inlet and outlet oil delivery pipes.

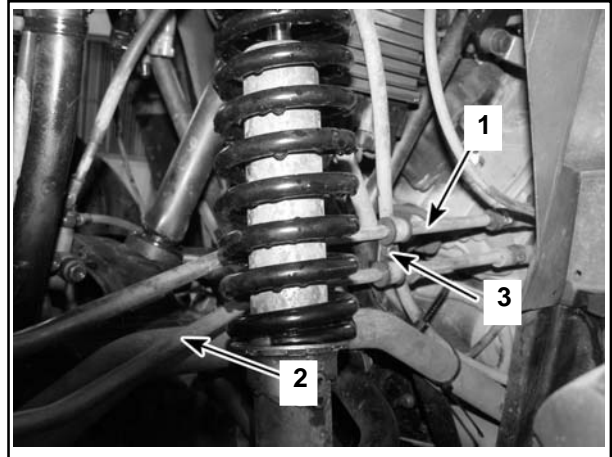

- 1. Inlet Oil Delivery Pipe
- 2. Outlet Oil Delivery Pipe
- 3. Holding Screw

Remove the 4 mounting bolts then oil radiator;

CAUTION: Drain the oil in the oil delivery pipe and oil radiator before removal.

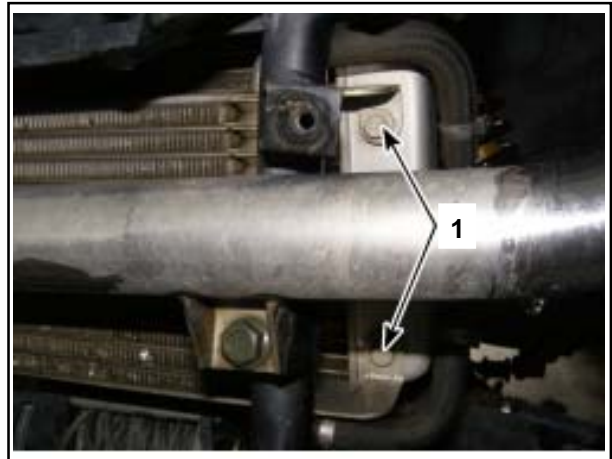

- 1. Oil Radiator Mounting Bolts

Remove engine inlet and outlet union bolts no.1;
Remove inlet and outlet oil delivery pipes.

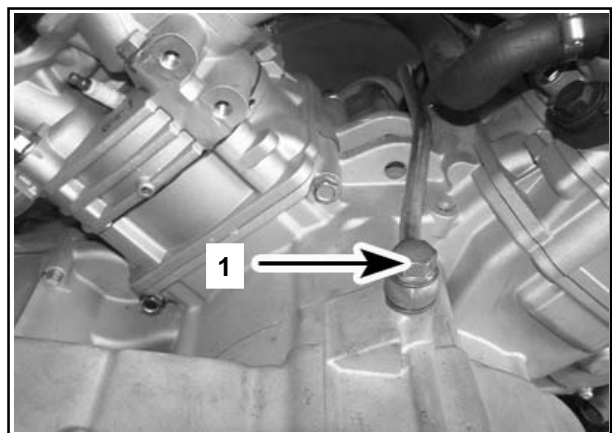

- 1. Union Bolt

Oil Delivery Pipe Inspection

Inspect oil delivery pipe for leaks, cracks and other damages. If so, replace it;

Always replace oil pipe clamp after removal.

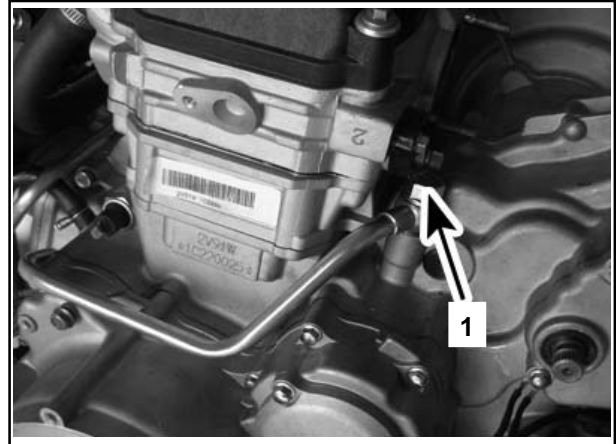

1. Engine Oil Outlet Union Bolt

Oil Radiator Inspection and Cleaning

Inspect radiator for deformation and bulge. If so, replace it;

Use an air gun to clean the dirt on radiator fins;

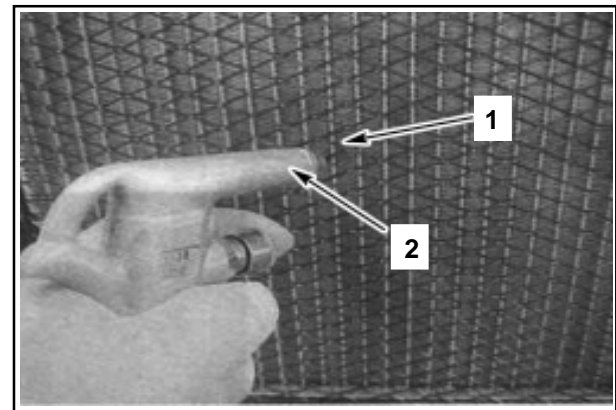

1. Oil Radiator

2. Air Gun

Inspect radiator fins for deformation. If so, use a small screw driver to repair the fins.

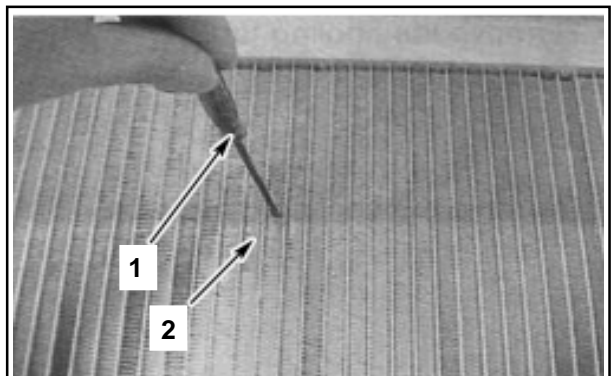

1. Screw Driver

2. Oil Radiator

Oil Delivery Pipe and Oil Radiator Installation

Reverse the removal procedure for installation.

Union bolt tightening torque: 25N • m.

MAGNETO SYSTEM

SERVICE TOOLS

Description	P/N	Page
Magneto Rotor Remover	0800-031000-922-001	6

SERVICE PRODUCTS

Description	P/N	Page
Engine Oil		
Threadlocker		
Loctite 5699(Silicone Sealant)		

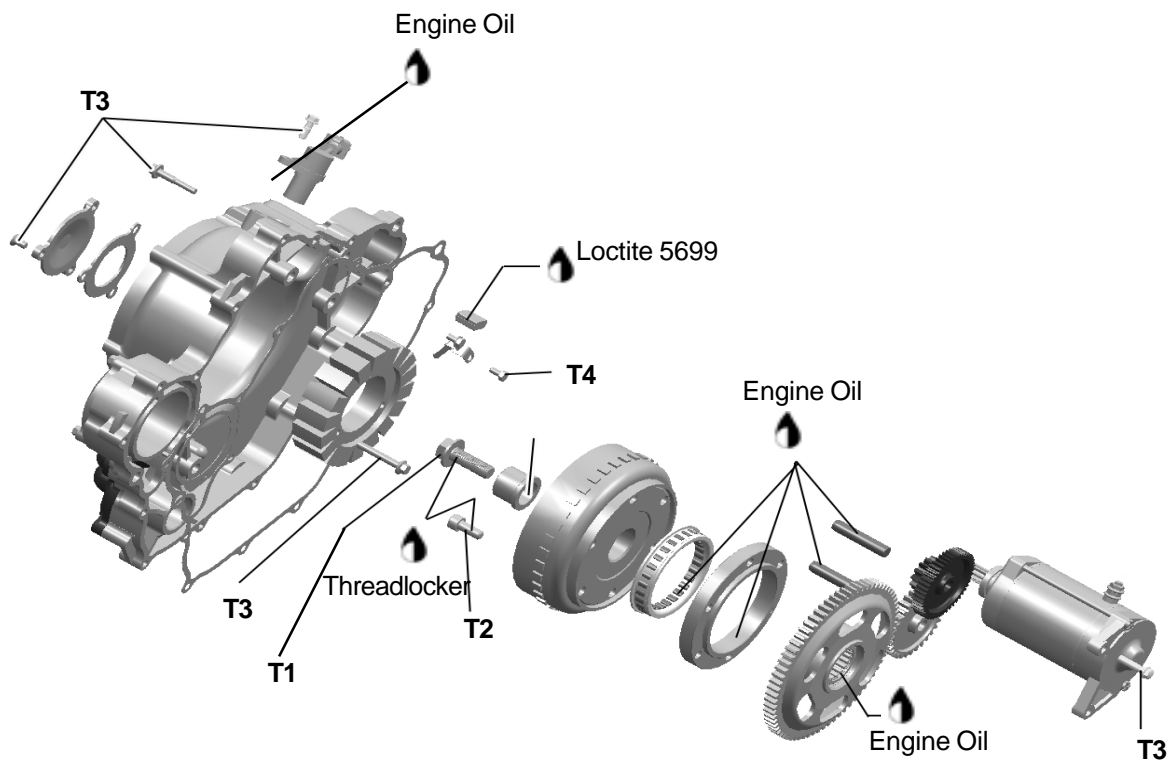

T1	105N • m(78lbf • ft)
T2	30N • m(22lbf • ft)
T3	10N • m(89lbf • in)
T4	4N • m(36lbf • in)

GENERAL

Always perform the electric tests before removing or installing whatever component.

During assembly/installation, use the torque values and service products as in the exploded view. Clean threads before applying threadlocker. Refer to **LUBRICANTS AND SERVICE PRODUCTS** at the beginning of this manual for complete procedure.

WARNING

Torque wrench tightening specification must strictly be adhered to. Locking devices. (e. g. : locking tabs , elastic stop nuts, cotter pins , etc.) must be installed or replaced with new ones where specified. If the efficiency of a locking device is impaired , it must be renewed.

MAGNETO COVER

Removal

Drain engine oil (refer to **LUBRICATION SYSTEM** and cooling system) and coolant;

Remove crankshaft position sensor(CPS);
Disconnect magneto connector;
Remove magneto cover retaining screws;

Remove magneto cover.

Inspection and Cleaning

Check magneto cover for cracks or other damages.
Replace if necessary.

Check working condition of rolling bearing. Replace if necessary.

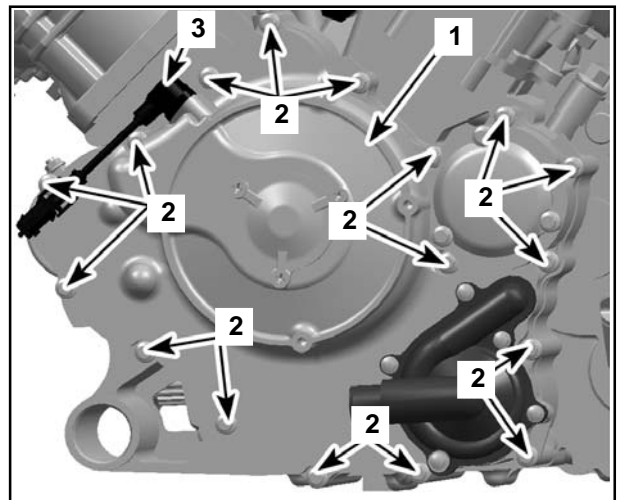

1. Magneto Cover
2. Retaining screws
3. CPS (crankshaft position sensor)

NOTE:

Clean all metal components in a nonferrous metal cleaner. Use suitable tool to remove gasket.

WARNING

Wear safety glasses and work in a well ventilated area when working with strong chemical products. Also wear suitable non-absorbent gloves to protect your hands.

Installation

For installation, reverse the removal procedure. Pay attention to the following.

NOTE:

*At installation replace magneto cover gasket.
Apply sealing compound on startor cable grommet as shown on the right.
apply grease on bearing*

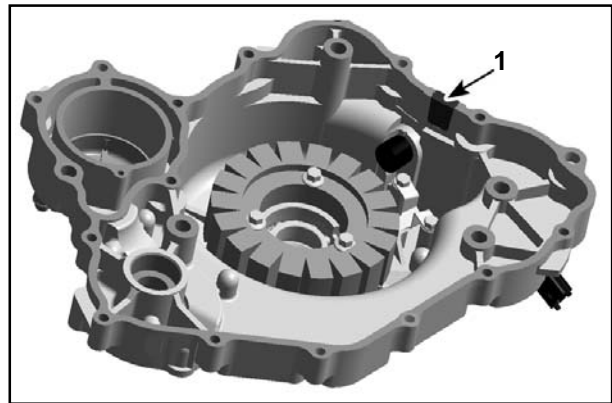

1. Apply Loctite 5699 (Silicone Sealant)

Tightening sequence for screws on magneto cover is as per following illustration.

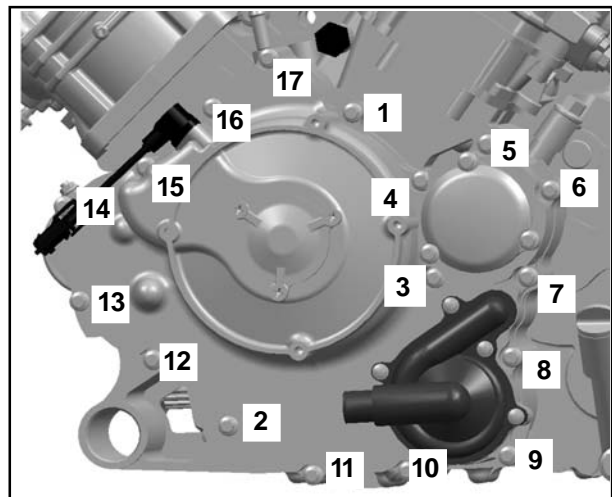

Tightening Sequence

Refill engine with recommended oil and coolant.

STATOR

Removal

Remove magneto cover(Refer to left *Magneto Cover Removal* above);

Remove screws securing holding strip;

Remove stator retaining screws then the stator.

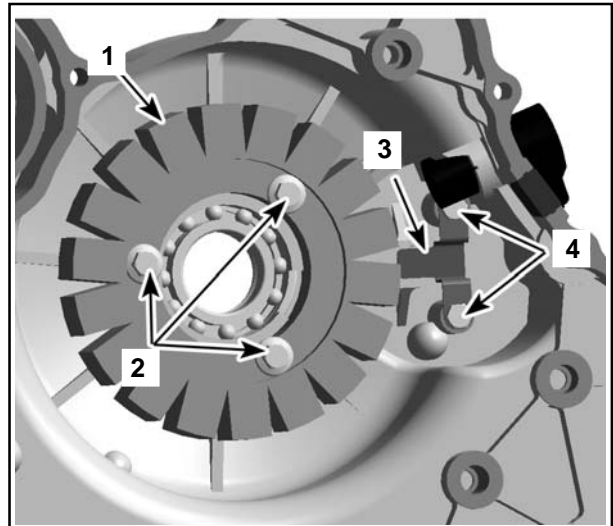

- 1.Stator
- 2.Stator retaining Screws
- 3.Holding Strip
- 4.Holding Strip screws

Inspection

Check stator condition, if damaged replace it.

Check if stator wires are brittle ,hard or otherwise damaged.



1.Stator

Stator Installation

For installation, reverse the removal procedure.

CAUTION:

When installing the stator take care that the cable is in place(guide for the wire).

NOTE:

There is only one position for the stator(notch in the magneto housing cover)

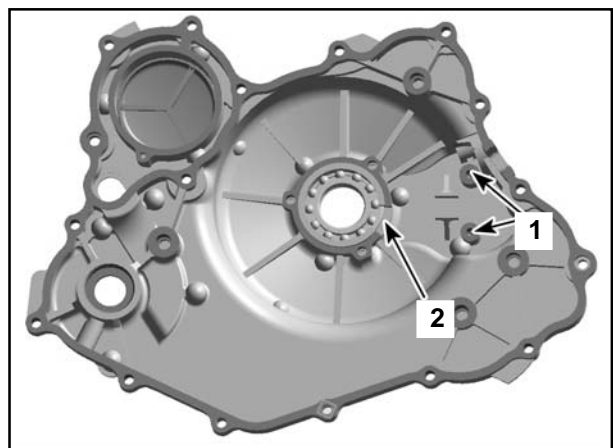

- 1.Threads for cable holding strip
- 2.Notch for stator

ROTOR

Removal

Remove magneto cover. (Refer to **MAGNETO COVER** above);

Remove screw and washer securing rotor to crankshaft.

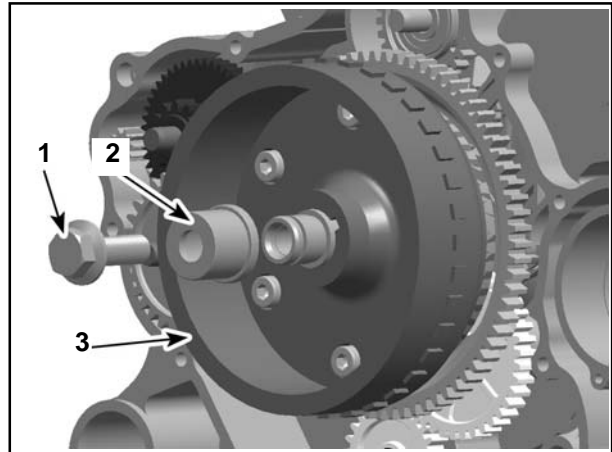

- 1. Bolt
- 2. Washer
- 3. Rotor

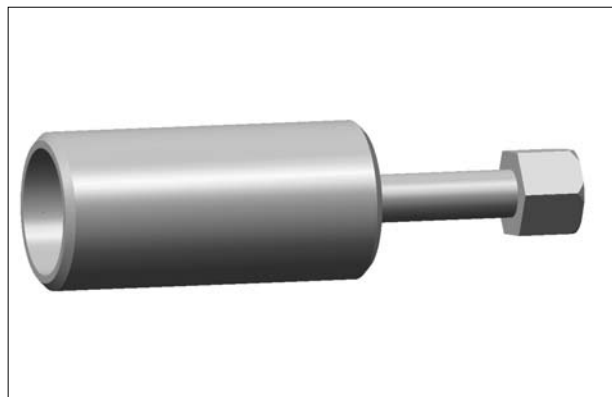

Install magneto puller and then remove rotor.

- 1. Magneto Puller

NOTE:

Use grease to magneto puller end prior to install rotor puller in order to protect crankshaft.

Screw magneto puller bolt to remove rotor.

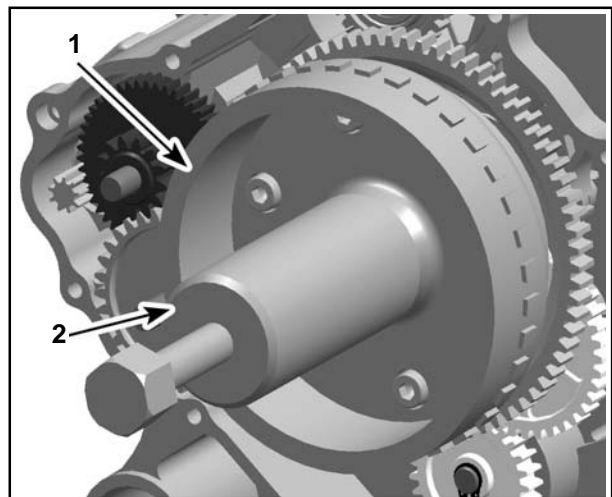

- 1. Rotor
- 2. Magneto Puller

Inspection

Check inner side of rotor for scratches or other damages.

Check keyway of rotor for wear or damages.

Check if trigger wheel teeth are bent or otherwise damaged.

Check woodruff key and keyway on the crankshaft for wear or damages.

Replace parts as necessary.

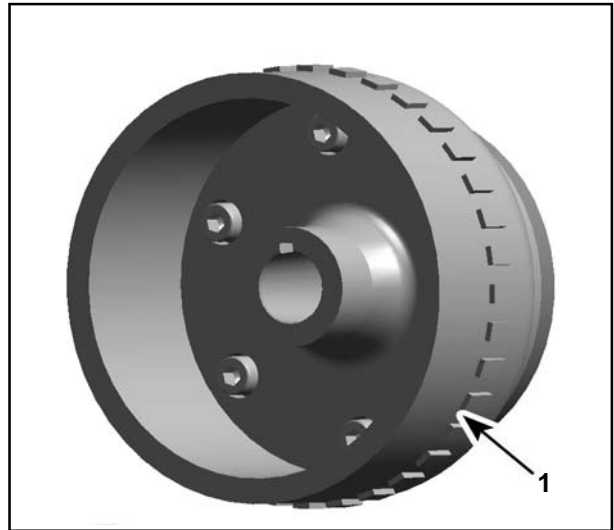

1. Rotor with trigger wheel

Installation

For installation, reverse the removal procedure.

Pay attention to the following.

Clean crankshaft taper and rotor with cleaner.

Oil sprag clutch in sprag clutch housing and install sprag clutch gear.

Slide rotor onto crankshaft. The woodruff key and the keyway must be aligned.

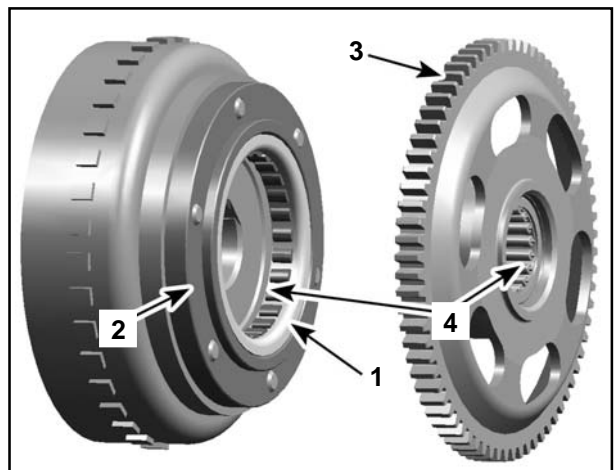

1. Sprag Clutch
2. Sprag clutch housing
3. Sprag clutch gear
4. Apply engine oil here

Slide spacer bush onto crankshaft and torque the bolt to specified value.
 Bolt tightening torque: 105N • m
 Rotate starter double gear counterclockwise to align intermediate gear teeth with clutch sprag gear teeth.

NOTE: Breather shaft end with chamfer should face outside.

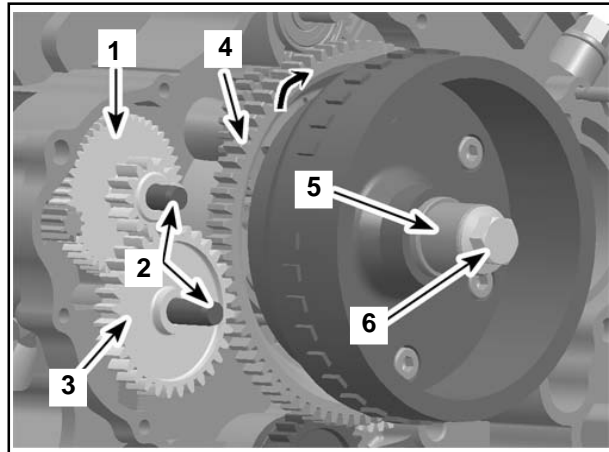

1. Double Gear 2. Breather Gear Shaft
 3. Intermediate Gear 4. Sprag Clutch Gear
 5. Spacer Bush 6. Bolt

SPRAG CLUTCH

NOTE: It is not necessary to remove if sprag clutch has no problem.

Sprag Clutch Removal

Remove magneto cover (refer to **MAGNETO COVER** above);

Remove rotor (refer to **ROTOR** above);

Remove sprag clutch gear;

Remove sprag clutch housing screws and sprag clutch housing.

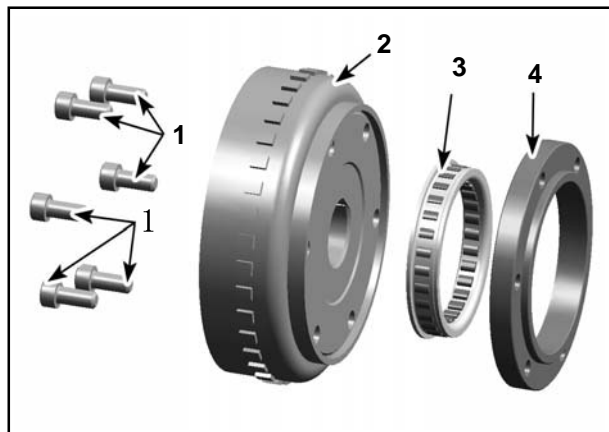

1. Bolt
 2. Rotor
 3. Sprag Clutch
 4. Sprag Clutch Housing

Sprag Clutch Inspection

Perform a functional test of the sprag clutch. To do so, rotate driven gear in sprag clutch.

Inspect sprag clutch and sprag clutch housing for wear and damage.

NOTE:

Sprag clutch must look in counterclockwise direction. Sprag clutch, housing and gear must be replaced at the same time, if damaged.



Sprag Clutch Functional Test

1. Lock Direction

Sprag Clutch Installation

For installation, reverse the removal procedure .

Pay attention to the following details.

Apply threadlocker on threads of sprag clutch housing screws.

Install rotor then torque sprag clutch housing screws to 30N • m.

Apply engine oil on sprag clutch and inside sprag clutch gear hole.

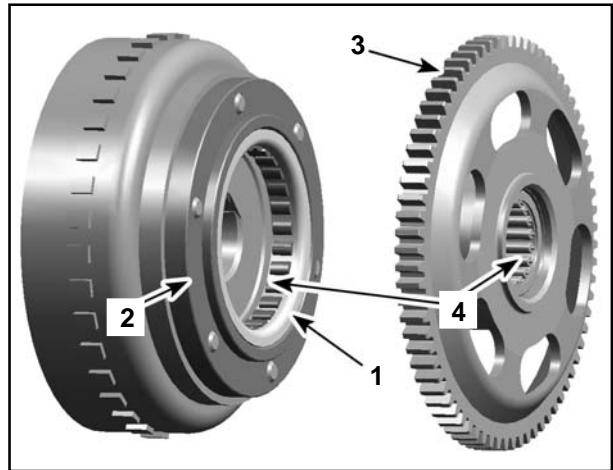

1.Sprag Clutch 2.Sprag Clutch Housing
3.Sprag Clutch Gear 4.Apply engine oil here

SPRAG CLUTCH GEAR

Removal

Remove rotor (refer to **ROTOR** above);

Pull sprag clutch gear from the rotor.

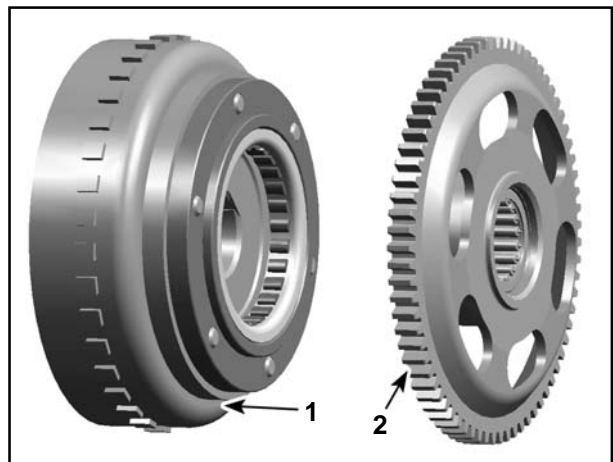

1.Rotor
2.Sprag Clutch Gear

Inspection

Inspect gear, especially teeth and sprag clutch collar, for wear and other damages.

Check needle bearing condition;

Replace Drive Gear if necessary.

Installation

Reverse the removal procedure for installation.

NOTE:

Apply engine oil on needle bearing and collar of drive gear.

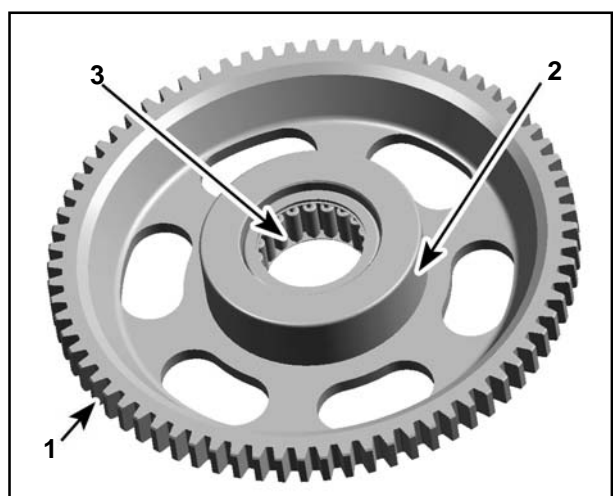

INSPECT

- 1.Teeth
- 2.Collar
- 3.Needle Bearing

STARTER DRIVE GEARS

The starter gears are located on the engine MAG side behind the magneto cover.

Removal

Remove magneto cover (refer to **MAGNETO COVER** above);

Remove breather shafts, double gear, intermediate gear.

Inspection

Inspect gears and shafts for wear and damage.

Installation

Reverse the removal procedure for installation.

NOTE:

Apply engine oil on every gear shaft and teeth.

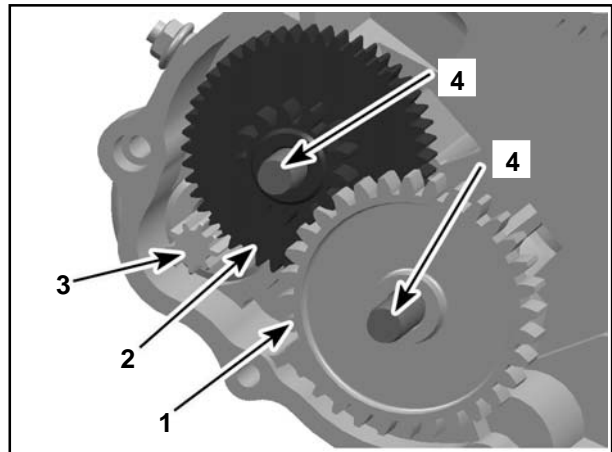

1. Intermediate Gear
2. Starter Double Gear
3. Starter Gear
4. Breather Shaft

12 FRONT WHEELS, BRAKE, SUSPENSION, STEERING

Check & repair information.....	12-1	Brake system.....	12-4
Troubleshooting.....	12-2	Front suspension.....	12-7
Front wheel.....	12-3	Steering system.....	12-12

MAINTENANCE INFORMATION

Operation Cautions:

CAUTIONS:

- Securely support the vehicle when doing check and repair.
- Do not overexert on the wheel, avoid any damage to the wheel.
- When removing tire, use the special tire lever and rim protector.

Maintenance Standard

Item		Standards	Service Limit
Front Wheel	Wheel Runout	Radial	0.8mm
		Axial	0.8mm
	Tire	Tread Depth	-
		Tire Pressure	45kPa
Front Brake	Brake Lever Free Play	0 mm	-

Tightening Torque

Nut, steering tie-rod	GB9457 M10x1.25	(30~40)	N•m
Lock nut, steering stem	GB6187 M14x1.5	(100~120)	N•m
Bolt, front brake disc	901-08.00.03	(25~35)	N•m
Bolt, front caliper	GB5789 M8x16	(15~25)	N•m
Axle nut	901-07.00.03	(15~25)	N•m
Bolt, front shock absorber	GB5789 M10x1.25x50, GB5789 M10x1.25x70	(15~25)	N•m
Wheel nut	901-07.00.02B	(70~80)	N•m
Bolt, A-arm	GB5789 M10x1.25x70	(40~50)	N•m

SERVICE TOOLS

- Rod, bearing remover
- Head 10mm, bearing remover
- Handle A, driving tool
- Sleeve 28x30, driving tool
- Guide tool 10mm
- Locknut spanner
- Bearing remover set
- Rotor puller
- Remover shaft
- Remover hammer
- Assembling tool shaft

TROUBLESHOOTING

Heavy steering

- Upper thread is over tightened
- Steering bearing is damaged or worn
- Inner&outer bearing races are damaged or not well tightened.
- Steering stem is distorted
- Low tire pressure
- Tire worn

Excessive handlebar free play

- Steering bearing is damaged or not well tightened.
- LH and RH shock absorber not matched
- Deflected tires
- Deformed frame
- Worn tire
- Shaking wheel bearing

Severe front wheel runout

- Wheel rim distorted
- Faulty wheel bearing
- Faulty tires
- mproper balance of wheels
- Imporper tightening of wheel shaft

Wheel cannot turn freely

- Faulty wheel bearing
- Wheel installed improperly
- Brake drag

Front suspension too shoft

- Weakened front shock absorber
- Tire pressure is too low

Front suspension too hard

- Front shock absorber is damaged
- Tire pressure is too high

Noise from front shock absorber

- Faulty front shock absorber
- Loosened tightening parts of front shock absorber

Poor brake performance

- Faulty brake adjustment
- Stained brake disc
- Brake pads worn

FRONT WHEEL

Removal

Securely support front wheels;
Remove wheel cap;
Remove the 4 wheel nuts no.1;
Remove front wheel.

Rim&Inspection

Check rim for damages,deformation,nicks.If any abnormal condition has been found,replace it.
Slowly turn wheel,use a dial gauge to measure the rim runout.

**Service limit: 2.0mm (Axial)
2.0mm (Radial)**

Installation

Press rim into tire with special tool;
Fix wheel on the hub;
Wheel nuts tightening torque:70-80 N • m



FRONT WHEEL HUB

Removal

Remove front wheel (→12-3);
Remove front brake caliper 5 (→12-4);
Remove rim axle nut no.2;
Remove brake disc and hub together;
Remove the 4 brake disc bolts no.6;
Remove front wheel hub no.4.

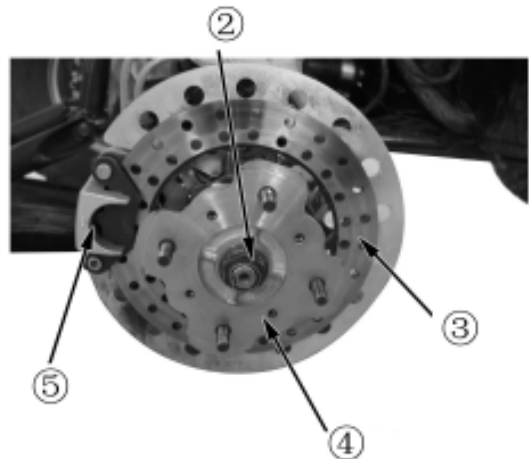

Installation

Reverse the removal procedure for installation.
Tightening torque of axle nut : 110-130N.m
Tightening torque of brake disc bolts no.6: 25-35N. m
(apply threadlocker)

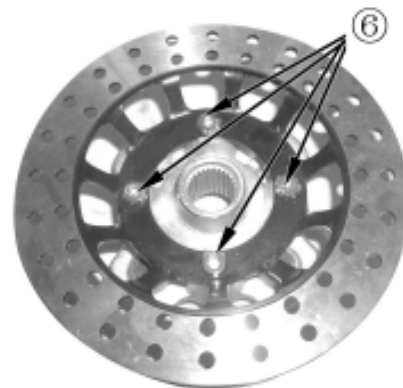

FRONT BRAKE SYSTEM

Front Brake Caliper

Removal

Remove front wheel(→12-3);

Remove the two bolts no.2;

Remove caliper no.1.

Inspection

Check any cracks of brake calipers and oil leaks from tightening areas. Replace if necessary.

Installation

Tightening torque of brake caliper bolt: 15-25N.m

(Apply threadlocker)

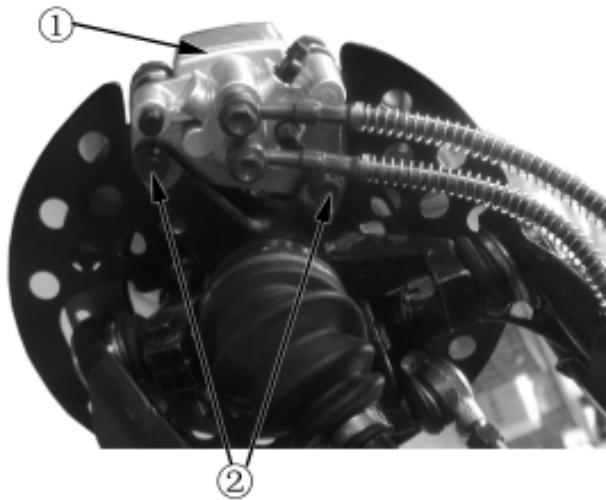

BRAKE PADS

Removal

Remove brake caliper (→12-4);

Remove main sliding shaft of brake pads with allen wrench;

Remove brake pads;

Measure thickness of brake pad friction surface no.4, if it is less than 1mm, then replace both pads at the same time.

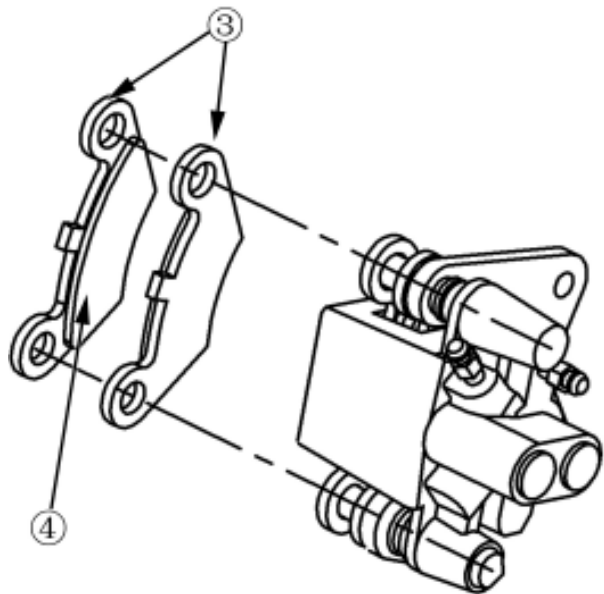

BRAKE DISC

Removal

Remove front wheel (→12-3);

Remove brake calipers (→12-4);

Remove brake disc and wheel hub from vehicle

Remove the 4 brake disc bolts shown in the right picture, then remove brake disc.

Inspection

Thickness of brake disc:

If less than 2.50mm,replace it.

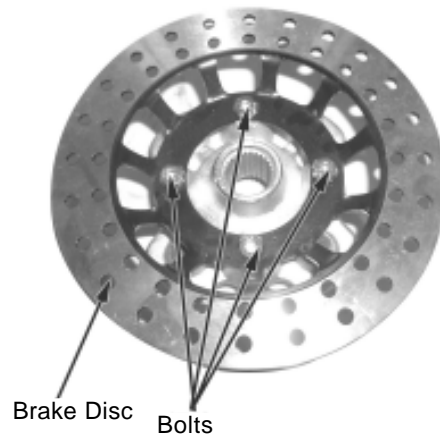

Installation

Reverse the removal procedure for installation.

Tightening torque of brake disc bolts: 25-30N.m

FRONT BRAKE MASTER CYLINDER

Removal

Remove top cover of handlebar;

Remove right hand guard;

Remove bolt no.2;

Separate master cylinder no.1 of front brake from handlebar. It's not necessary to remove it if replacement is not required.

Attention:

Do not hang the master cylinder by brake line, keep master cylinder in place (not inclined) while installing it to avoid air entering brake line.

Keep brake line routed properly (refer to Chapter 1) and ensure it is not kinked.

After installation of brake system, check brake performance.

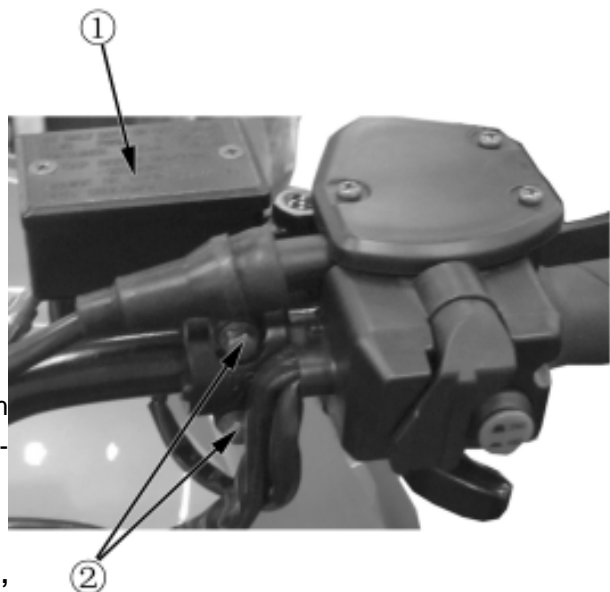

4-WHEEL MASTER CYLINDER

Removal

- Remove brake pedal (→ 2-11);
- Remove bolts no.2;
- Remove bolts no.4;
- Remove cotter pin no.9;
- Remove master cylinder no.1 from vehicle.

Installation

Reverse the removal procedure for installation.

Attention:

- In order to avoid air entering 4-wheel master cylinder, keep it in place while installing it.
- Keep brake line routed properly (refer to Chapter 1) and ensure it is not kinked.
- After installation, check brake performance.

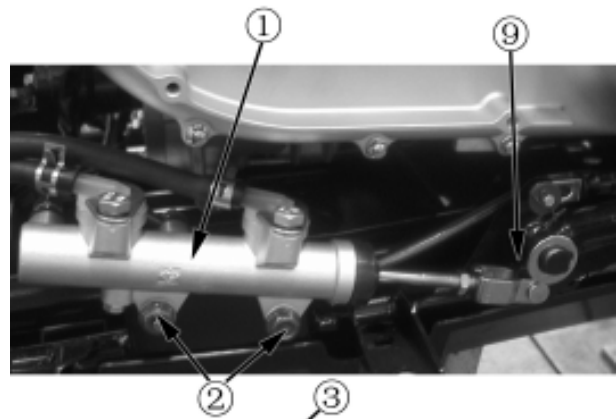

T-FITTING

Removal

Remove bolt no.6 and T-fitting.

Installation

Reverse the removal procedure for installation.

- Attention:** Keep brake line routed properly (refer to Chapter 1) and ensure it is not kinked.
- After installation, check if 4-wheel brake lever or brake pedal can control front brake.

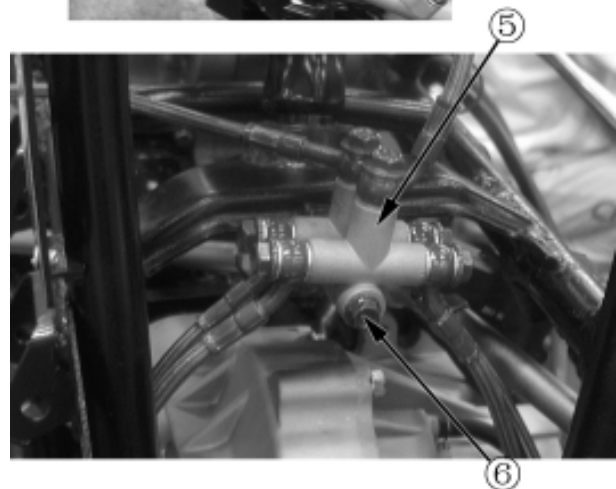

REAR BRAKE CALIPER

Disassembly

Remove bolt 7 and then disassemble rear brake caliper 8

Installation

Reverse the removal procedure for installation.

- Attention:** Keep brake line routed properly (refer to Chapter 1) and ensure it is not kinked.
- After installation, check if 4-wheel brake lever or brake pedal can control front brake.

Maintain brake fluid level between "UPPER" and "LOWER", if necessary, add DOT 4 fluid (CFMOTO recommended) into brake fluid reservoir. Check brake light and switch.

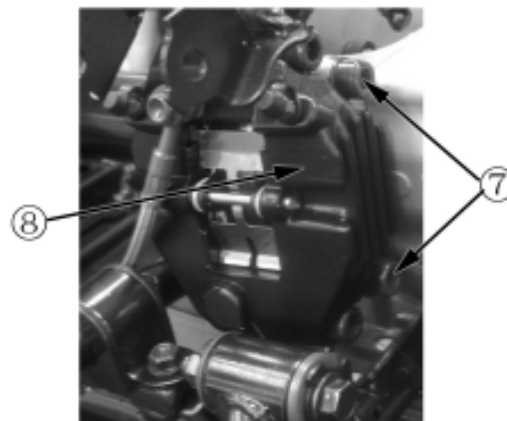

FRONT SUSPENSION

Front LH Suspension

ATTENTION:Do not remove left and right suspension at the same time, otherwise vehicle may tip or fall.

Removal

Park the vehicle on a level ground and securely support the front part of vehicle.

Remove LH front protector of suspension (→2-15);

Remove front wheel (→12-3);

Remove brake caliper (→12-4);

Remove front wheel hub (→12-3);

Remove bolts and nuts no.2 of front LH shock absorber and LH upper A-arm;

Remove front shock absorber no.1;

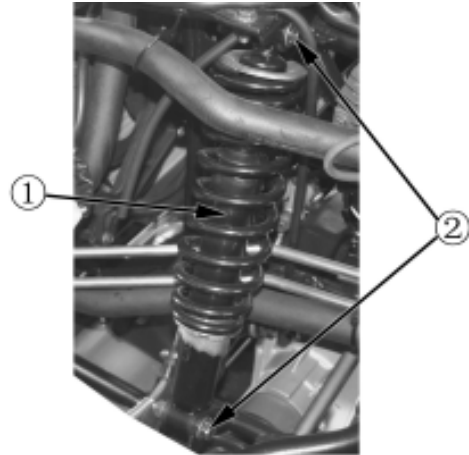

Remove bolts and nuts no.3 of LH front A-arm;

Remove cotter pin and nut no.5 assembled on left steering knuckle;

Remove front LH upper A-arm 4;

Remove cotter pin and locking nut no.8 of steering tie-rod;

Remove bolts and nuts no.6 of LH front A-arm assembled on frame;

Remove locking bolt no.9 of LH front A-arm;

Remove front LH lower A-arm no.7;

Remove steering knuckle from drive shaft;

There are optional shock absorbers available for different markets.

The procedure above is for basic configuration. As for other optional shock absorbers, refer to the procedure above.

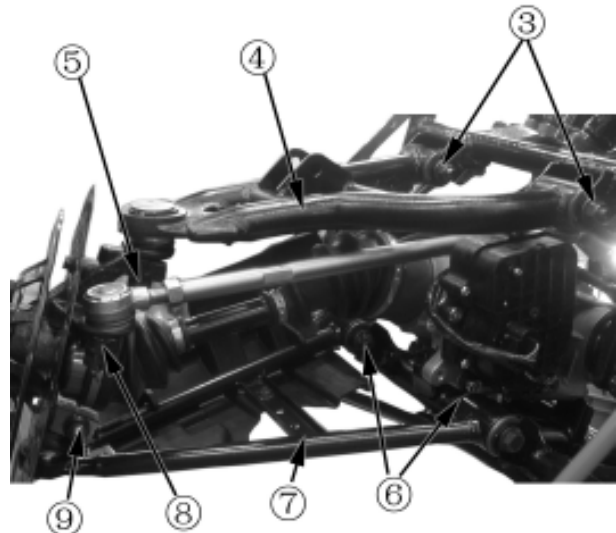

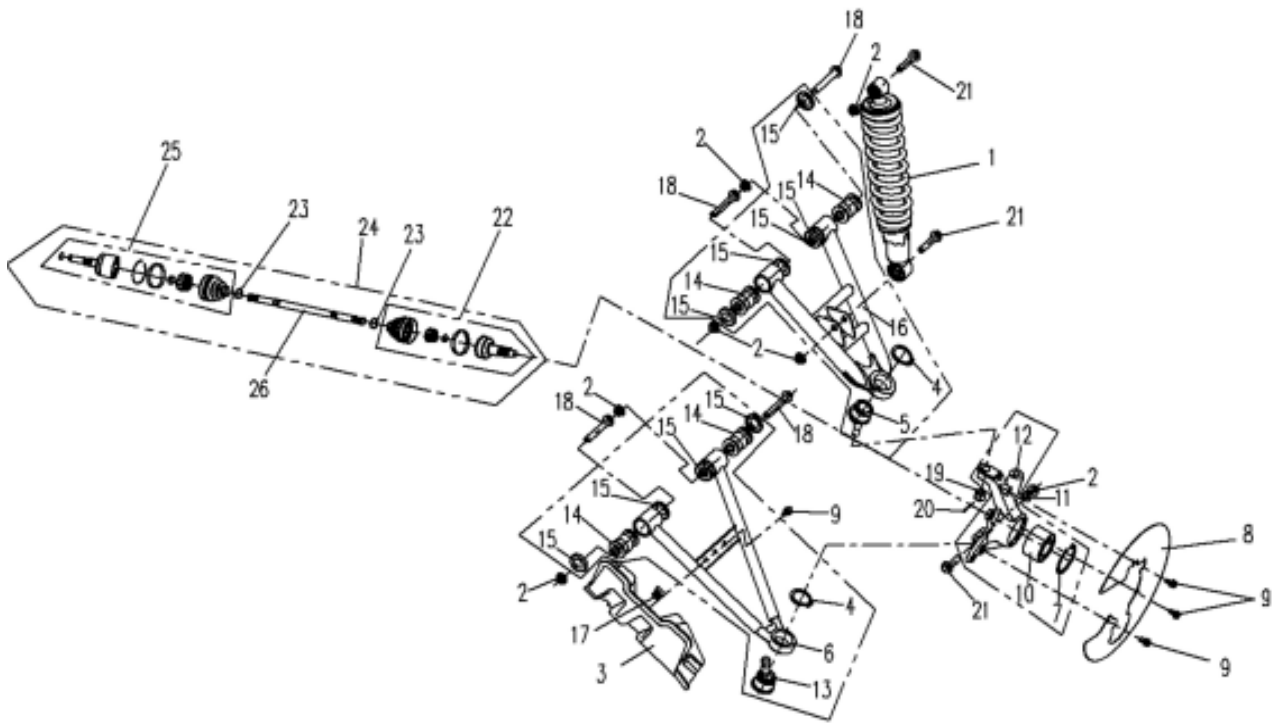

1.Front shock absorber 2.Nut 3. LH protector 4.Circlip 5. Top ball pin 6.LH front lower A-arm 7.Circlip 8. Guard,brake disc 9.Bolt 10.Hub bearing 11.Washer 12.LH steering knuckle 13. Bottom ball pin 14.Buffering collar 15.Cap, buffering collar 16.LH front upper A-arm 17.M6 Nut clip 18. Bolt 19. Slot nut 20. Cotter pin 21. Bolt 22. Bearing kit, fixing end 23. Small clamp 24.Front LH drive shaft assy 25.Bearing kit,motion end 26. Front LH drive shaft

FRONT SHOCK ABSORBER

Removal

NOTE: *If only replacing front shock absorber, it's not necessary to remove other parts.*

Remove bolt no.21 and nut no.2, then finally remove front shock absorber (LH) no.1.

Inspection

Check shock absorber for oil leaks, oil seal aging and other damages. Replace if necessary.

Installation

Reverse the removal procedure for installation.

As for removal, installation and check procedure of front shock absorber (RH),refer to front shock absorber (LH).

A-ARM

NOTE: *There are totally 8 units of A-arm, procedure of removal, disassembly, check and installation is same, so only front upper A-arm (LH) and front lower A-arm(LH) are introduced.*

Front LH A-arm

Removal

Remove front shock absorber(LH) (→12-7);
Remove bolt no.18 and tightening nut no.2 mounting front LH upper A-arm on frame;
Remove bolt 18 and tightening nut mounting front LH lower A-arm on fram;
Remove front wheel, brake caliper and wheel hub before disassembling shock absorber;
Remove steering tie-rod before the removal of bolts;
Remove steering knuckle from drive shaft before removal of front LH A-arm ;
Finally remove front LH A-arm.

Inspection of upper A-arm

Remove front Upper A-arm (LH) no.3(→12-7);

Remove circlip no.2 (Type: GB894.1 34)

Remove top ball pin no.1;

Check top ball pin no.1 if it can move freely and also check its clearance. If it cannot move freely or too big clearance, replace it. At the same time, check grease inside top ball pin if it is deteriorated. Check dust boot of ball pin if damaged or aging;

Remove bushing no.5 of front upper A-arm(LH);

Check bushing no.5 if damaged or aging, replace if necessary.

Inspection of Lower A-arm

Remove front Lower A-arm (LH) no.3(→12-7);

Remove circlip no.2 (Type: GB894.1 34)

Remove top ball pin no.6;

Check top ball pin no.6 if it can move freely and also check its clearance. If it cannot move freely or too big gap, replace it. At the same time, check grease inside top ball pin if it is deteriorated. Check dust boot of ball pin if damaged or aging.

Remove bushing no.5 of front upper A-arm(LH)

Check bushing no.5 if damaged or aging, replace it if necessary.

Installation

Use special tool to press ball pin into A-arm;
Install as reverse procedures of disassembly.

Attention: Upper and Lower A-arms should not vibrate after installation, otherwise replace bushing no.5.

Inspection of Left Steering Knuckle

Remove left steering knuckle no.10 (→12-7);

Remove circlip no.8 (Type: GB893.1 55);

Use special tool to remove hub bearing no.9 (Type: DAC3055);

Check hub bearing if any damaged and move freely, or big clearance. Replace it if necessary.

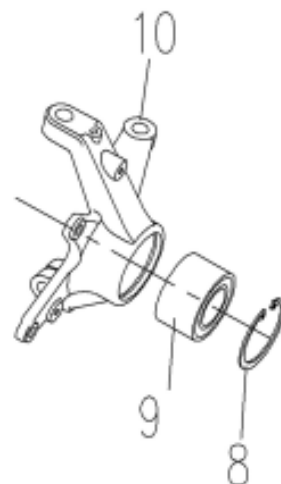
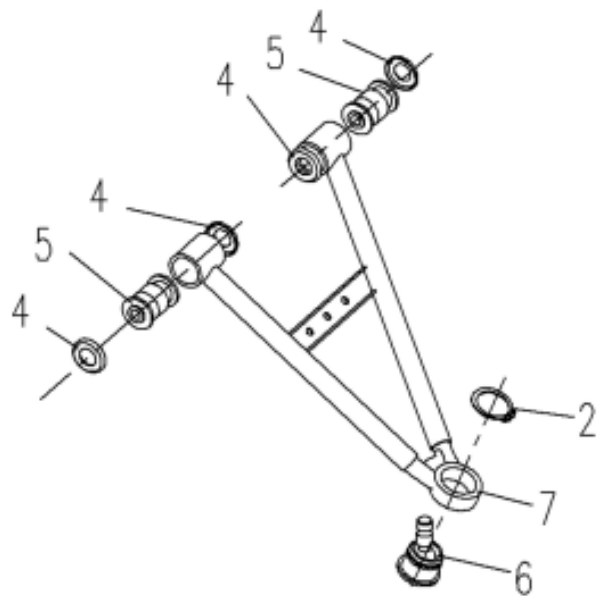
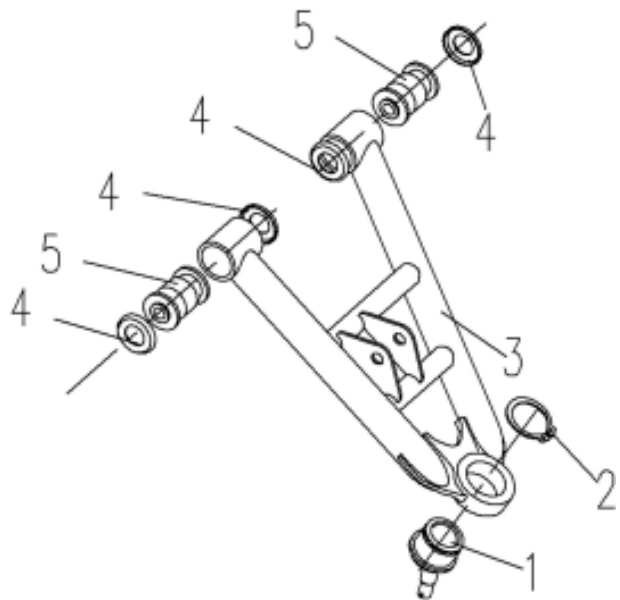

DRIVE SHAFT

NOTE: Method and procedure of removal, inspection and installation between front and rear drive shafts (LH & RH) are similar, therefore only front drive shaft (LH) is introduced.

Front LH Drive Shaft

Removal

NOTE: If only repairing front LH driveshaft, it's not necessary to remove front LH suspension from vehicle.

Remove front wheel(LH)(→ 12-3);

Remove front caliper (LH)(→ 12-4);

Remove front wheel hub (LH)(→ 12-3);

Remove front LH drive shaft no.3 from left side of front differential;

Check dust boot if any damaged. If damaged, replace it.

Check bearing kit of fixed and motion end if it can move flexibly. Also check there is any clearance between universal joint and splines. If it cannot move freely and there is noise, replace it.

CAUTION: Universal joint must move freely, otherwise it can damage drive shaft and cause out of control of tire and accident.

Installation

Reverse the removal procedure for installation.

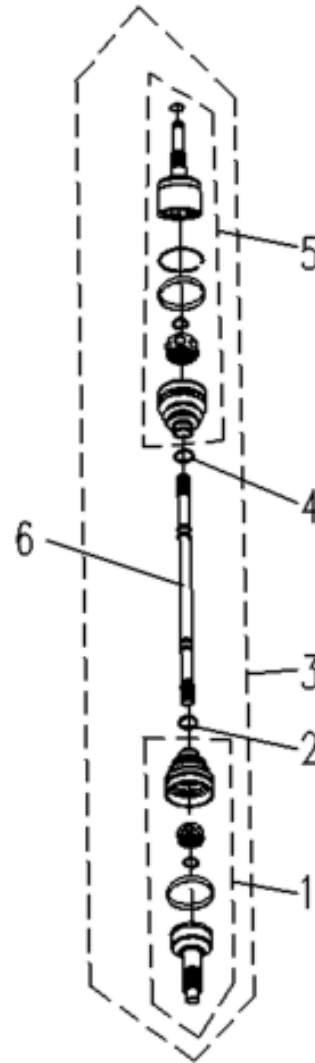

STEERING

Handlebar

Master cylinder of front brake (→ 12-15);

Top cover of handlebar

Removal

Remove tapping screw no.1;
Remove top cover of handlebar.

Installation

Reverse the removal procedure for installation.

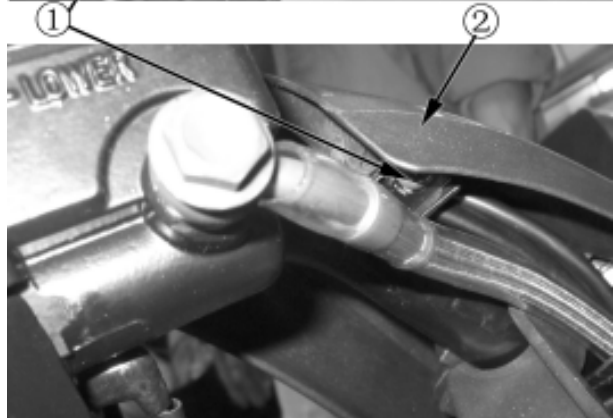

4-WHEEL HAND BRAKE LEVER

Removal

Remove bolts no.3;
Remove 4-wheel hand brake lever;

Installation

Reverse the removal procedure for installation.

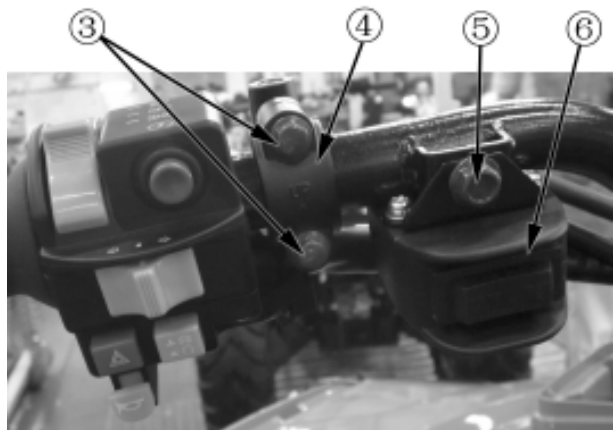

WINCH CONTROL SWITCH

Removal

Remove bolt no.5;
Remove winch control switch no.6.

Installation

Reverse the removal procedure for installation.

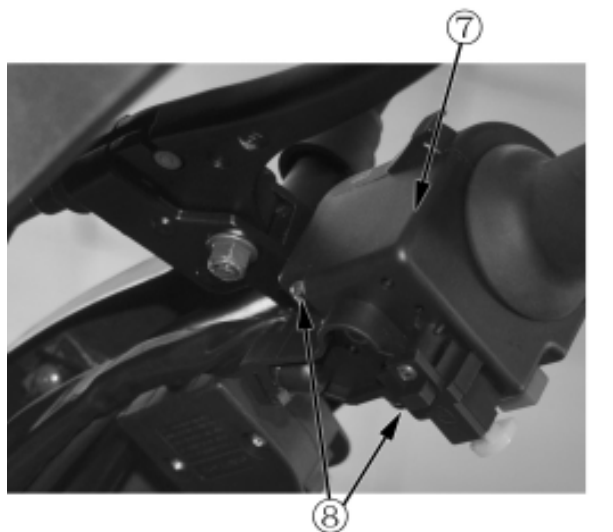

LH HANDLEBAR SWITCHES

Removal

Remove bolts no.8;
Remove left handlebar switches no.7.

Installation

Reverse the removal procedure for installation.

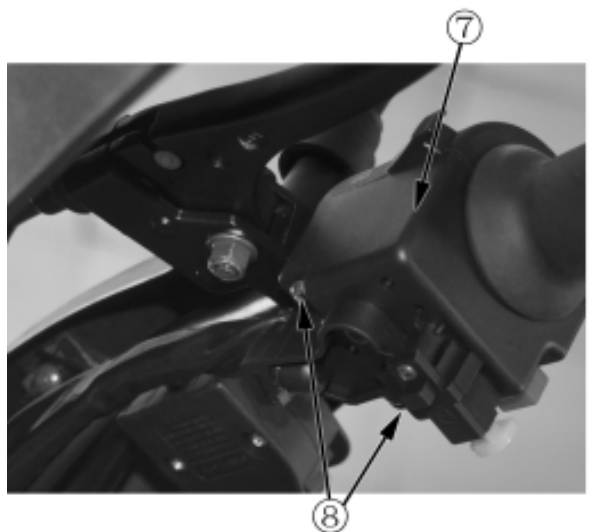

RH HANDLEBAR SWITCHES

Removal

Remove bolts no.2;

Remove right handlebar switches no.1;

Unplug connector no.3 of left handlebar switches,
Unplug connector no.4 of right handlebar switches.

Installation

Reverse the removal procedure for installation.

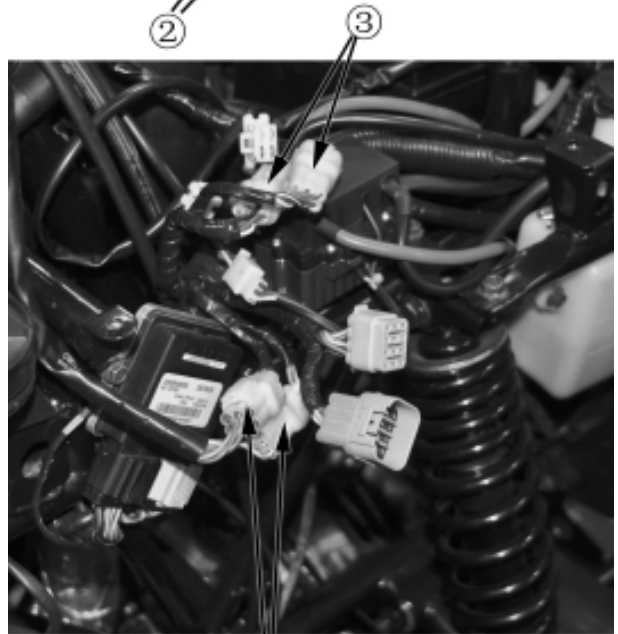

REAR VIEW MIRROR

Removal

Slide sleeve no.6 out place and unscrew no.nut 7, then remove rear view mirror no.5 in anti-clockwise direction.

NOTE: As for rear view mirror (LH), the threads are right hand, so remove it by turning it counter-clockwise. Unscrew nut in clockwise direction and unscrew rear view mirror (RH) to remove.

NOTE: As for rear view mirror (RH), the threads are left hand, so remove it by turning it counter-clockwise.

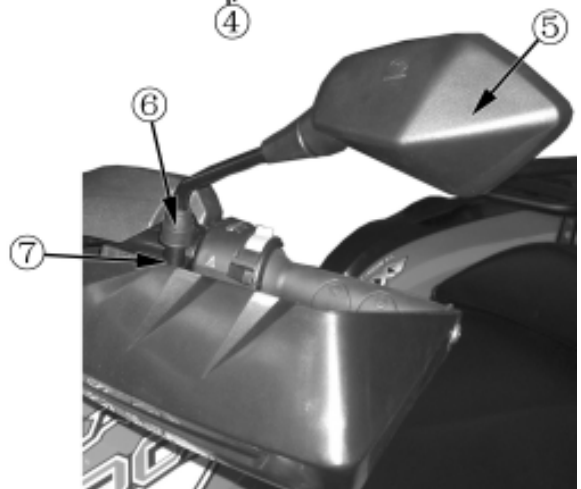

Installation

Reverse the removal procedure for installation.

HANDLEBAR

Removal

Remove top cover of handlebar (→12-12);
Remove left and right handlebar switch (→12-12);
Remove left and right brake pump from handlebar;
Remove left and right hand protector;
Remove bolt 1 of handlebar cover;
Remove handlebar no.2.

Installation

Reverse the removal procedure for installation.
Handlebar cover bolt: GB5789 M8x55
Tightening torque: 15-25N•m (1.5-2.5kgf•m)

ATTENTION:

Keep Main cable, throttle cable, brake line properly routed.



Throttle Cable Installation

Remove the 3 screws illustrated in the right picture and remove top cover of right handlebar;
Install throttle cable;
Install top cover of right handlebar.

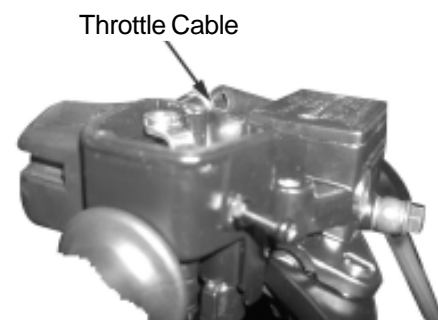
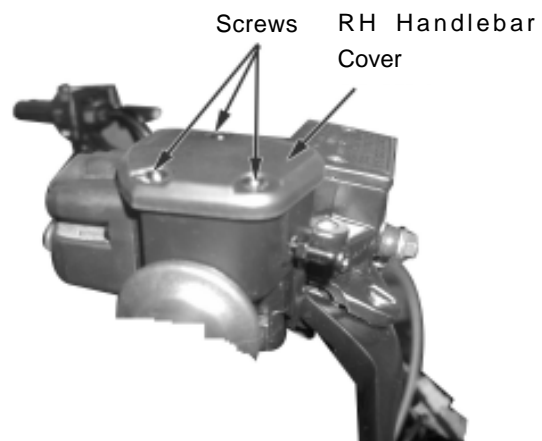

12 FRONT WHEELS,BRAKE,SUSPENSION,STEERING

STEERING EXPLODED VIEW

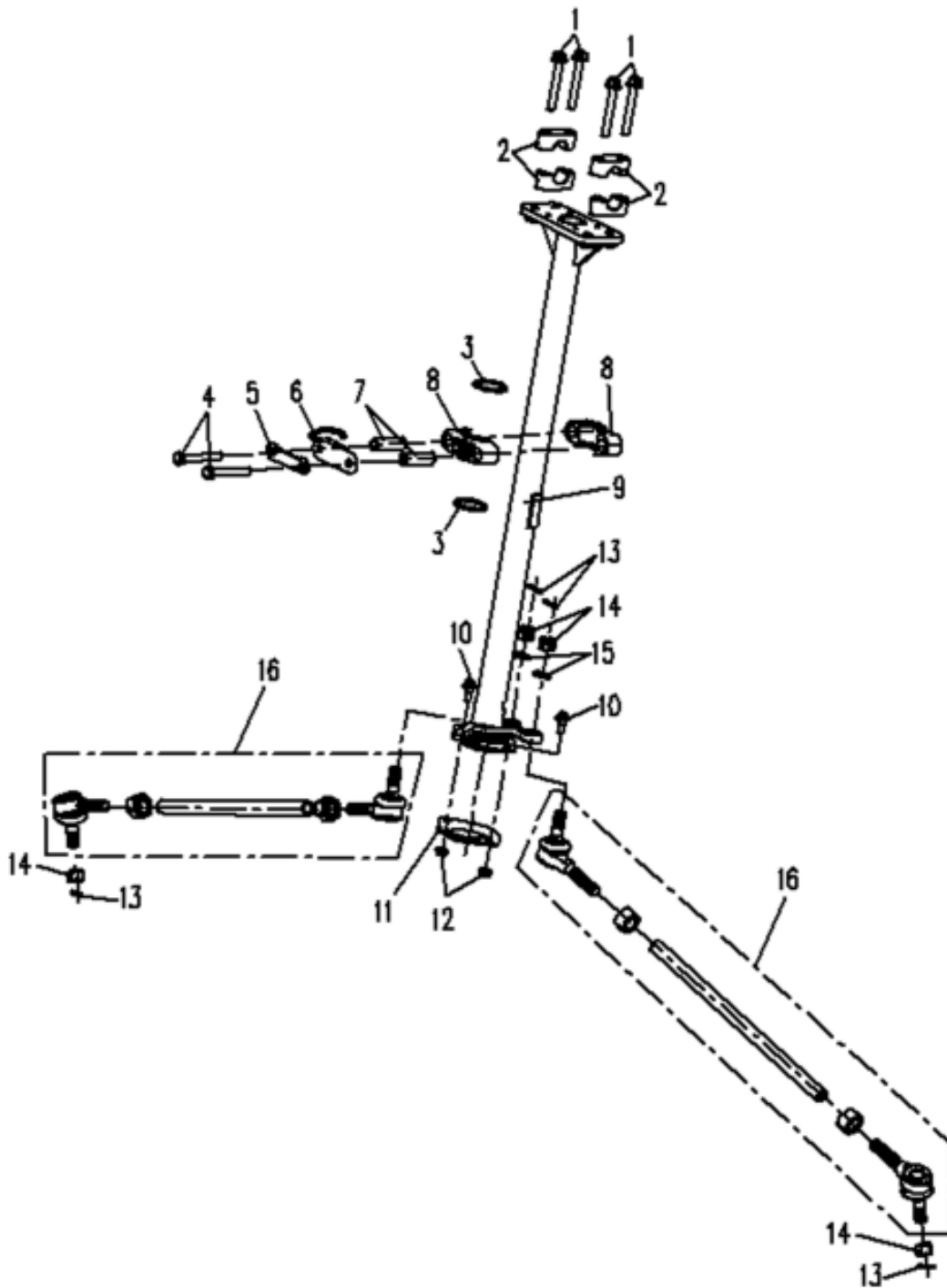

1.Bolt 2.Alum. cover, handlebar 3. Seal ring 4. Bolt 5.Lock clip 6.Adapter plate 7.Bush 8.Support bush, steering bearing 9.Steering stem 10. Flange bolt M6x17 11. Steering bearing seat 12. Nut 13. Cotter pin 14.Nut 15. Washer 16. Steering tie-rod

STEERING COLUMN

Removal

- Remove plastics(→Chapter 2);
- Remove upper cover of handlebar (→8-12);
- Remove front wheel (→8-2);
- Remove handlebar (→8-14);
- Remove 4-wheel hand brake lever(→8-12);
- Remove connector of handlebar switches;
- Remove nut of steering tie-rod and steering column;
- Use slotted screw driver and hammer to fix lock clip;
- Remove bolt no.1;
- Remove cotter pin;
- Remove steering tie-rod nut and washer;
- Press steering tie-rod away from steering column;
- Remove bolt no.14;
- Lift steering bearing away from steering stem;

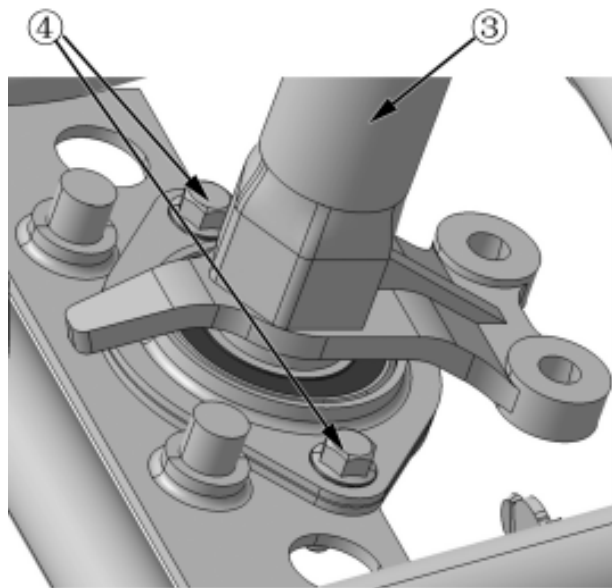
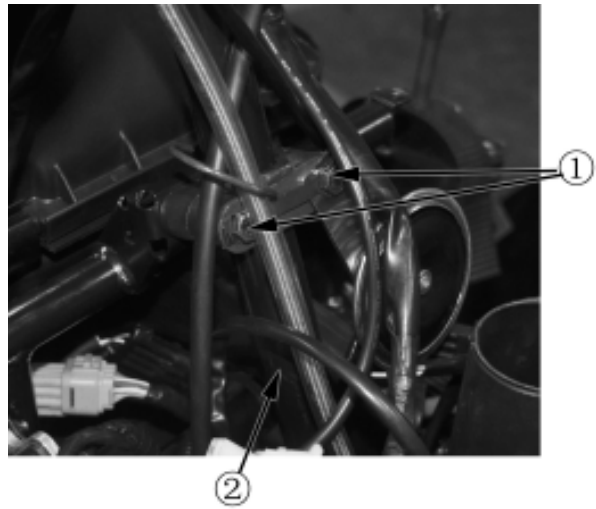

Installation

Reverse the removal procedure for installation.

NOTE: After installation, be sure to check steering agility.

STEERING BEARING & OIL SEAL

Removal

Remove steering bearing (→8-16);

Steering bearing and oil seal are pressed onto steering column, check if any damaged. If damaged, please replace it.

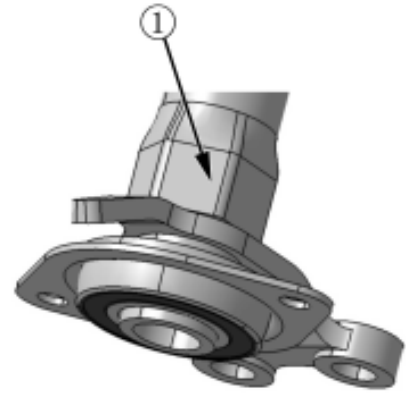

Installation

Reverse the removal procedure for installation.

NOTE: After installation, it is necessary to check steering agility.

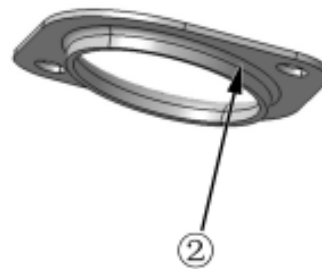

13 REAR WHEELS,BRAKE,SUSPENSION

Maintenance Information.....13-1
Troubleshooting.....13-2
Rear Wheels.....13-3

Rear Brake System.....13-4
Rear Suspension.....13-5

MAINTENANCE INFORMATION

Operation Cautions

CAUTION:

- When performing rim,suspension maintenance,jack or other suitable stand is required to raise the vehicle body off the ground.
- Rim,suspension mounting bolts,nuts should be genuine parts.
- Never exert an excess force on the wheels.Be careful not to damage wheels.
- when removing tires from wheels,use special tools,such as tire removal rod and tire protector to avoid damages to rims.

Maintenance Specifications:

Item		Standards	Service Limit	
Rear Wheel	Wheel Runout	Radial	-	2.0mm
		Axial	-	2.0mm
	Tire	Tread Depth	-	3.0mm
		Tire Pressure	45kPa	-
Rear Brake	Brake Lever Free Play	10-20mm	-	

Tightening Torque:

- Axle Nuts: 110-130N • m
Wheel Nuts: 70-80N • m
Upper Shock Mounting Bolts&Nuts: 40-50 N • m
Lower Shock Mounting Bolts&Nuts: 40-50 N • m

Troubleshooting

Rear wheel runout

- Wheel deformation
- Defective tire
- Tire pressure is excessively low
- Wheel is unbalanced
- Axle nut is loose
- Wheel nuts are loose

Too soft rear shock

- Weakened spring tension
- Rear shock leak

Too stiff rear shock

- Rear shock bending
- Too high tire pressure

Poor braking performance

- Improperly adjusted braking
- Brake pads or disc is damaged or stained
- Brake pads is worn

REAR WHEEL

Removal

See the front wheel removal.(→12-3)

RIM&CHECK

Check rim for damages,deformation,nicks.If any abnormal condition has been found,replace it.
Slowly turn wheel,use a dial gauge to measure the rim runout.

Service Limit:

Radial:2.0mm

Axle:2.0mm

Installation

See front wheel installation(→12-3).

WHEEL HUB

Removal

Remove rear wheel(→13-3);

Remove rear axle nut;

Remove wheel hub.

Installation

Reverse the removal procedure for installation.

Axle Nut Tightening Torque:110-130N • m

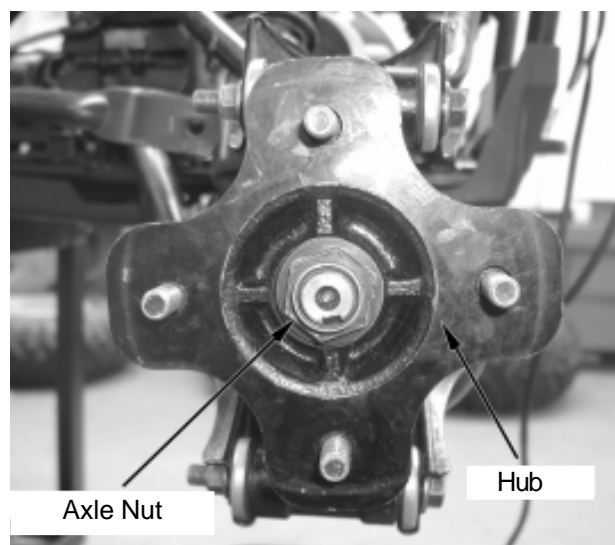

REAR BRAKE SYSTEM

Rear Brake Caliper

Removal

Remove rear wheel, LH(→13-3);
Remove the 2 bolts fitted on A-arm;
Remove brake caliper.

Inspection

Visually inspect caliper for cracks and brake fluid leaks.
Replace the part if any damage has been found.

Installation

Reverse the removal procedure for installation.

NOTE: Refer to Chapter 1 for brake line routing.

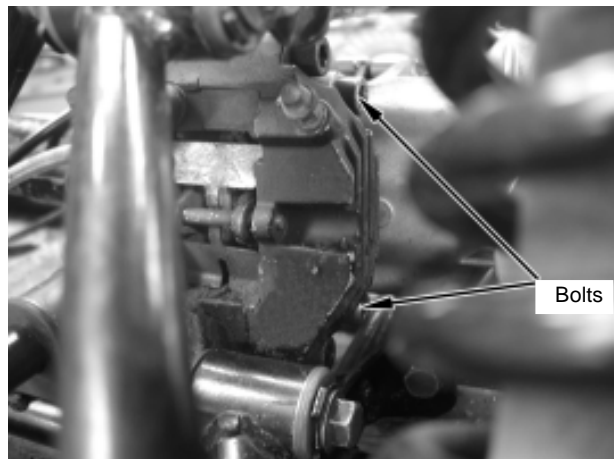

Brake Disc

Chapter 1

Remove the drive shaft;
Remove rear caliper(→3-4);
Remove the 6 rear brake disc mounting 6 bolts ;
Remove brake disc(→ 13-3).

Inspection

Replace the brake disc if it's thickness is less than 6.5mm.

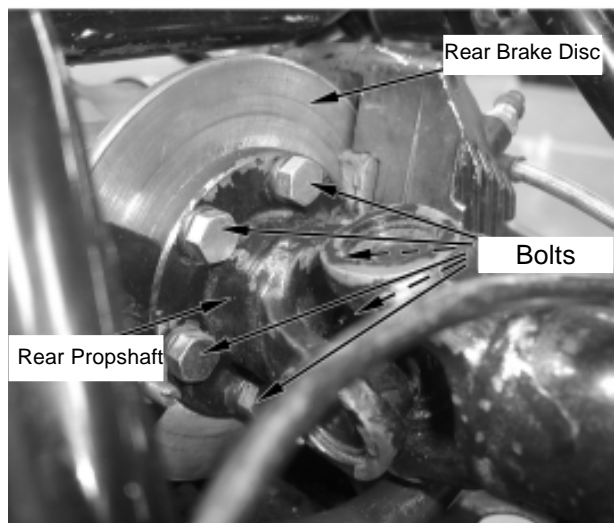

Measuring Rear Brake Pads no.1

If the brake pad friction surface no.2 \leq 1mm, replace the 2 brake pads no.1 as an assembly.

Installation

Reverse the removal procedure for installation.

NOTE: Refer to Chapter 1 for brake line routing.

A whole brake system replacement:(→Chapter 12, Brake System)

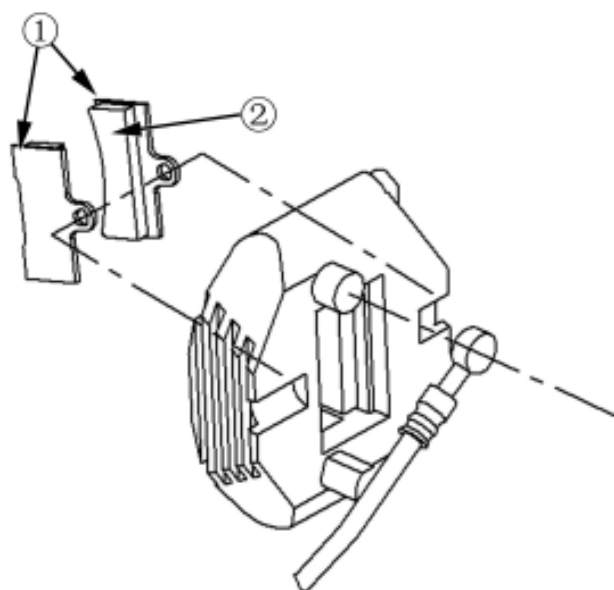

REAR SUSPENSION

Rear Suspension,LH

NOTE: When servicing suspension, don't remove LH suspension and RH suspension at the same time. Otherwise, vehicle may tip or fall.

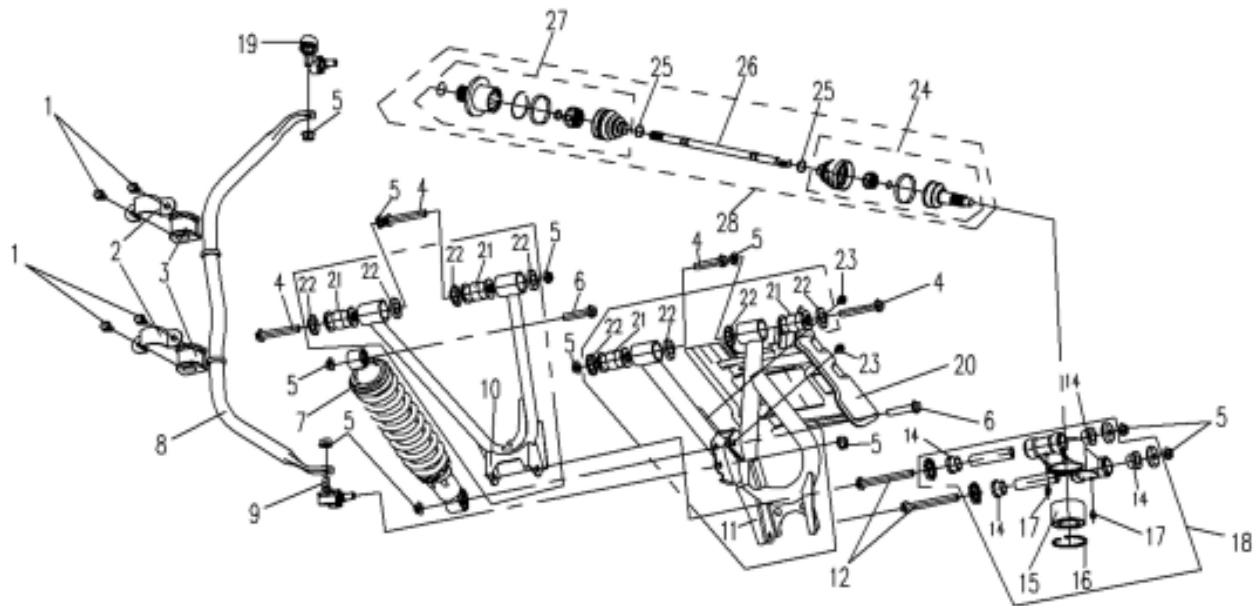

- 1.Bolts 2.Gland Cover 3.Rubber Support 4.Bolt 5.Self-locking Nut 6.Bolt 7.Rear Shock,LH 8.Stabilizer Bar 9.Rear LH Ball Pin 10.Real LH A-arm 11.Rear Upper A-arm,LH 12.Rear Lower A-arm,LH 13.Bolt 14.Bushing 15.Bearing 16.Circlip 17.Grease Fittings 18.Bearing Carrier 19.Rear RH Ball Pin 20.Rear LH Suspension protector 21.Buffering Collar 22.Cap,Buffering Collar 23.Bolt 24.Bearing Kit,Fixed End 25.Small Clamp,Fixed End 26.Rear LH Axle 27.Rear Bell Boot,Motion End,LH 28.Front Axle,LH

Disassembly

STABILIZER BAR

Removal

Remove bolt no.1;Remove gland cover no.2 and rubber support no.3;Remove self-locking nut no.2;Remove LH ball pin no.9 and RH ball pin no.26;Remove stabilizer bar.

Installation

Reverse the removal procedure for installation.

REAR LH SHOCK ABSORBER

NOTE: *When removing LH&RH shock, use appropriate tool to support and raise the vehicle body.*

If only shock requires maintenance, it's not necessary to remove the complete suspension system before service.

Remove rear LH shock mounting bolt and nut;

Remove rear LH shock.

Installation

Reverse the removal procedure for installation.

REAR A-ARMS, LH

See *Front LH Upper/Lower A-arm Removal, Inspection, Installation* in Chapter 8.

REAR SUSPENSION, RH

See rear *LH Suspension Removal, Inspection, and Installation*.

MAINTENANCE INFORMATION

● Standards

Lubricating Period				
Item	Type	Capacity	Interval	
			Initial	Next
Front Differential	SAE15W/40 SG or SAE80W/90 GL-4	Initial:0.33L /Replace:0.28L	350km	5000km
Rear Gearcase		Initial:0.30L/Replace:0.25L		

Item	Qty	Specification	Toque(N.m)	Remark
Bolt,F/D	6	M8X28	25	
Motor Screw,F/D	4	M8X20	13	
Bolt,Shift Fork Rack Stopper	1	M8X10	13	Apply threadlocker
Nut,F/D	1	M14X1.5	62	
Bolt,R/G	6	M10X1.25X22	45	
Fill Bolt,F/D	1	M10X1.25X12	25	
Drain Bolt,F/D	1	M10X1.25	25	
Retainer,F/D	1	M64X1.5X7	80	
Bolt,R/G	2	M10X1.25X25	40	
Bolt,R/G	6	M8X25	25	
Nut,Drive Pinion Gear Shaft,R/G	1	M12X1.25	70	
Bolt,Bearing Carrier,R/G	4	M8X30	25	
Retainer,R/G	1	M65X1.5X10	70	
Nut	1	M8	16	
Fill Bolt,R/G	1	M20X1.5X12	25	
Drain Bolt,R/G	1	M14X1.25X12	25	

F=Front,D=Differential,G=Gearcase,R=Rear

● Inspection & Maintenance

Inspection and maintenance is required if any of problems below happened to front differential and rear gearcase.

Problem Description	Possible Causes
1.A pronounced hesitation or “jerky” movement during acceleration,deceleration,or sustained speed.	A.Bearing damage; B.Improper gear lash; C.Gear severely worn;
2. Abnormal noise in front differential and/or rear gearcase.	D.Gear blocked E.Drive shaft broken F.lack of lubrication
3.No power transmitted from the engine to the front and/ or rear wheel.	G.Foreignn objects in the front differential and/or rear gearcase

NOTE: *Problems A,B and C above may be difficult to diagnose.The symptoms are quite subtle and difficult to distinguish from normal machine operating noise.If there is reason to believe these components are damaged,remove the components and inspect them.*

Observation and Judgement

1.Investigate any unusual noises:

a. Unstable noise during acceleration or deceleration.The noise increases with front and/or rear wheel speed,but it does not increase with higher engine or transmission speed.

Diagnosis:Possible wheel bearing damage.

b. Constant abnormal noise during acceleration or deceleration might be caused by improper gear lash during assembly.

NOTE:*Improper assembly or adjustment of the front differential and/or rear gearcase will aggravate gear wear and block;*

c.Slight noise would be noticed during low-speed driving, while may not be heard during high-speed driving. This symptom might be caused by gear block.

WARNING:*In case of above mentioned itmes, stop riding immediately for inspection and fix the problem before successive use.otherwise it will cause loss of control of the machine and possible injury to the rider.*

2.Check lubrication condition;

Often check if the consumption of lubricant is normal and the metal particles in lubricant is normal.

3.Chcek lubricant leakage;

a.Check front differential and rear gearcase housing for oil residue throughly;

b.Oil residue on ground on the parking lot;

c.Lubricant splash inspection.Check if there is gear case or oil seal leakage. Replace broken parts if necessary.

14 FRONT DIFFERENTIAL/REAR GEARCASE

FRONT DIFFERENTIAL EXPLODED VIEW

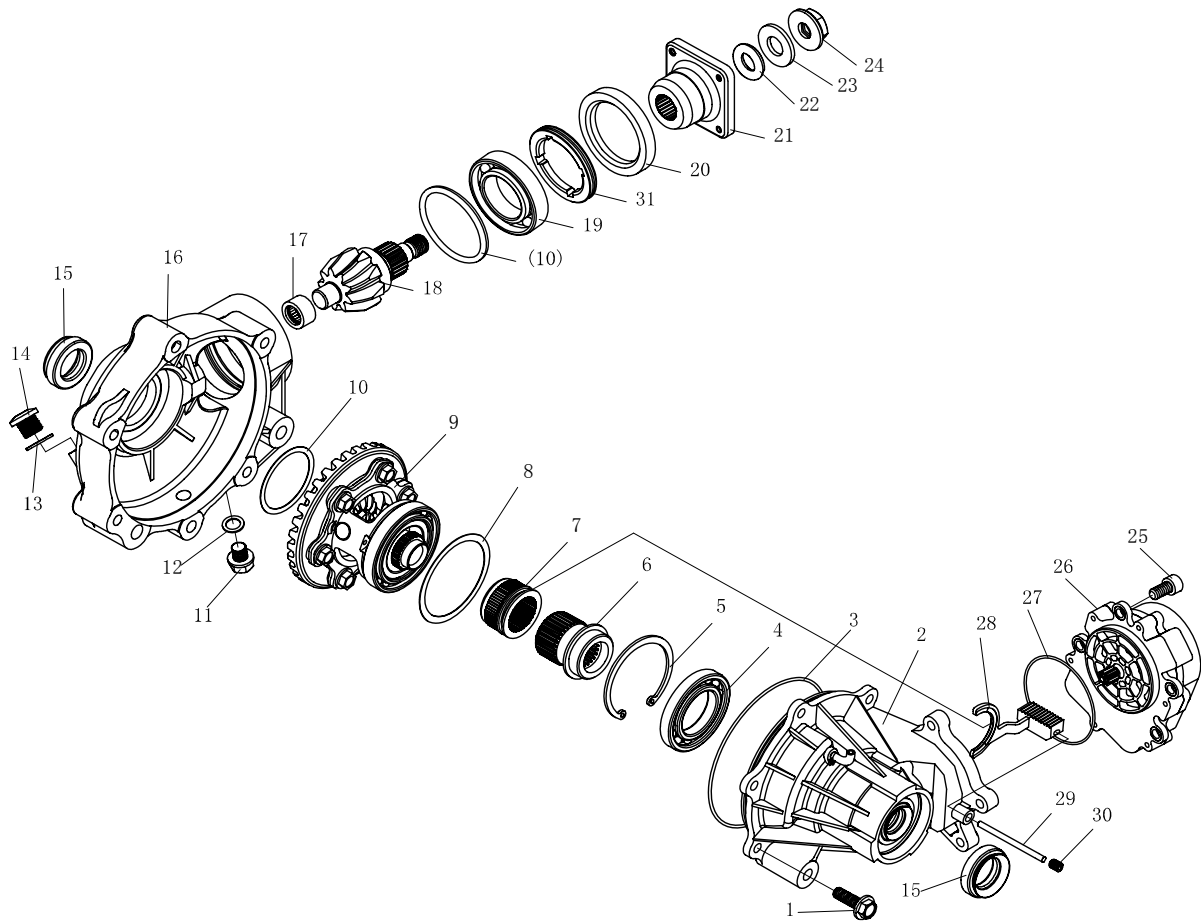

Item	Part Name	QTY	Item	Part Name	QTY
1	Bolt M8X28	6	17	Bearing F1512	1
2	Differential Gear Case,LH	1	18	Drive Pinion Gear	1
3	O-ring 141X2.4	1	19	Bearing 6007	1
4	Bearing 16007	1	20	Oil Seal 48X65X9	1
5	Circlip 62	1	21	Coupler	1
6	Drive Clutch Cover	1	22	O-ring 14X6.8	1
7	Drive Clutch	1	23	Nut Washer	1
8	Shimφ83X71	1-2	24	Nut M14X1.5	1
9	Differential Gear Assembly	1	25	Screw M8X20	4
10	Shim φ61X48	2-4	26	Gear Motor	1
11	Drain Bolt M10X1.25	1	27	O-ring 81.2X1.9	1
12	Washer 10,Drain Bolt	1	28	Shift Fork Rack	1
13	Washer 14,Fill Bolt	1	29	Stopper Shaft	1
14	Bolt M14X1.25	1	30	Screw M8X10	1
15	Oil Seal 24X38X8	2	31	Retainer M64x1.5X7	1
16	Differential Gear Case,RH	1	32		

Inspection After Front Differential Disassembly

- Check if there is damage or cracks on the front differential gear case and the condition of bearing seats. Replace if necessary.
- Check front differential bearing free play, rotation, bearing cage, steel balls, needles conditions. Replace if necessary (Using special tools).
- Check if oil seal lips and O-ring shape are normal. Replace if necessary.
- Check cylindrical surface that contacts oil seal lips condition. Replace if necessary.
- Check teeth of front differential drive pinion gear and ring gear. Replace if necessary.
- Check differential spider gears teeth, gear carrier for wears. Replace if necessary.
- Check differential inside and outside splines for wears. Replace if necessary.
- Check rack face, inspect worn surface. Replace broken parts if necessary.
- Check gear motor working status. Replace with new parts if necessary.
Gear motor inspection must be carried out with special equipment or acted on the vehicle.
- Check other parts. Replace broken parts if necessary.

Front Differential Assembly and Adjustment

● Front RH Differential Gear Case Assembly

Item "31" tightening torque: 80N • m

Item "24" tightening torque 62N • m

NOTE: Apply engine oil on oil seal, bearing and drive clutch assembly;
Apply threadlocker on item "24".

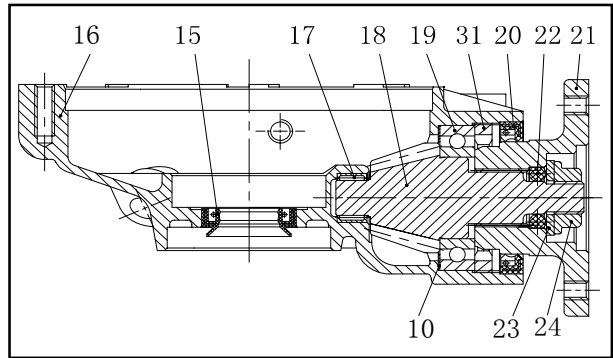

● Front LH Differential Gear Case Assembly

NOTE: Use engine oil for oil seal or bearing assembly.

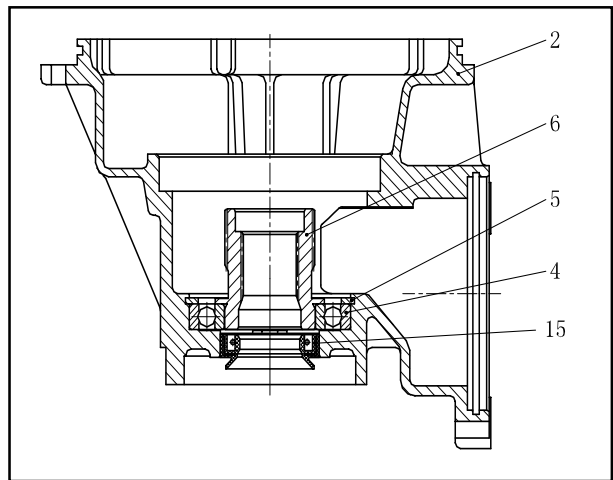

● Differential Gear Assembly

Bolt M10 X 1.25 X 22 tightening torque 45N • m

NOTE: Use engine oil for bearing and differential gear;
Use proper shim to make gear work freely;

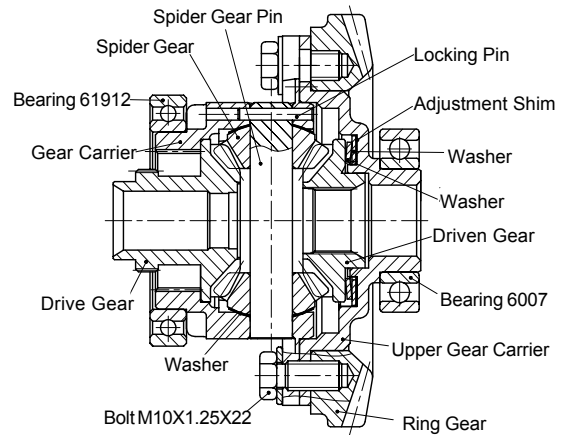

Shim	0.1	0.2	0.3	0.4
thickness	0.5	1.0		

●Front Differential Assembly and Adjustment

Assemble front differential as illustrated:

Tightening Torque	
Item "1"	25N•m
Item "25"	13N•m
Item "30"	13N•m
Fill Bolt	25N•m
Drain Bolt	25N•m

Use threadlocker for item "30" assembly.

a Use proper shim no.8 and no.10 to adjust gear lash between drive pinion gear and ring gear.

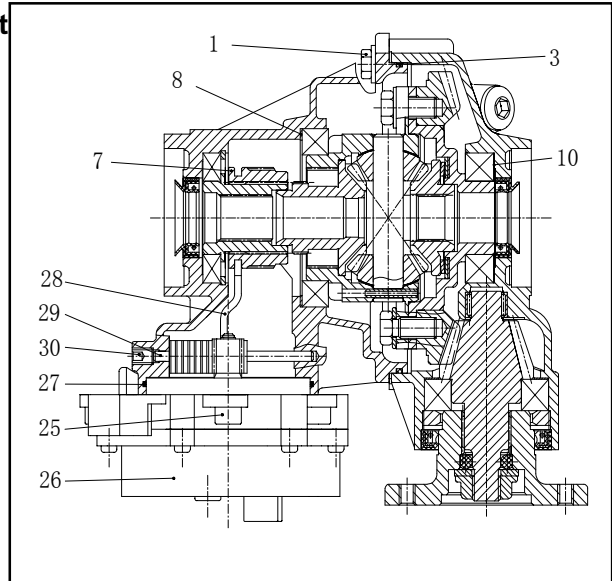

Measure the lash between drive bevel gear and driven bevel gear as illustrated: Install gear lash measurement tool no.1, locking bolt(M10X1.25X60) no.2. Using a dial gauge, make sure the measuring point is 21mm (0.83 in). Rotate gear lash measurement tool from engagement to engagement.

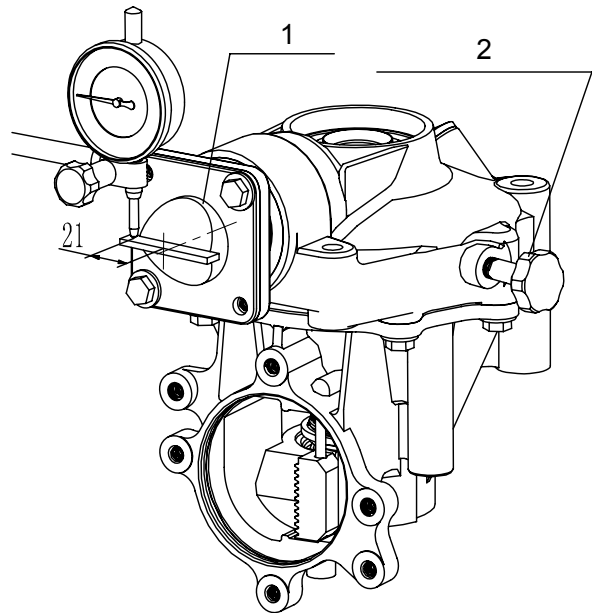

Standard: 0.10 ~ 0.25

Shim thickness	0.1	0.2	0.3	0.4
	0.5	1.0		

b When assembling front differential gear motor, shift fork rack and drive clutch should be against tightly as the arrow points.

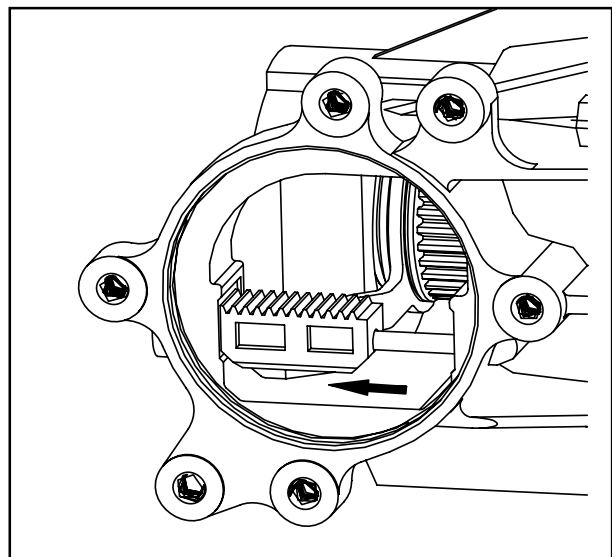

14 FRONT DIFFERENTIAL/REAR GEARCASE

c Using special equipment or vehicle control circuit, switch diff. motor to 2WD before assembly.

d Make sure b and c is assembled properly and use illustrated position screw M8X100 no.1 to assemble differential gear motor and front differential.

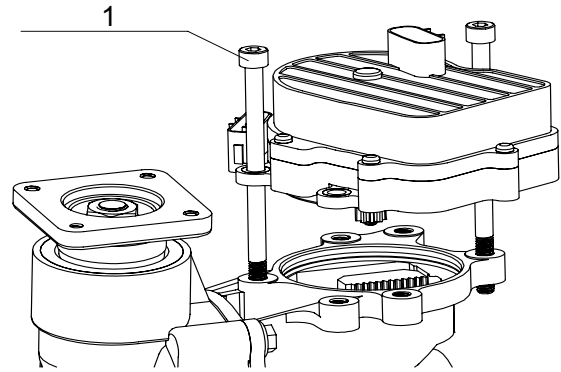

14 FRONT DIFFERENTIAL/REAR GEARCASE

FRONT DIFFERENTIAL EXPLODED VIEW

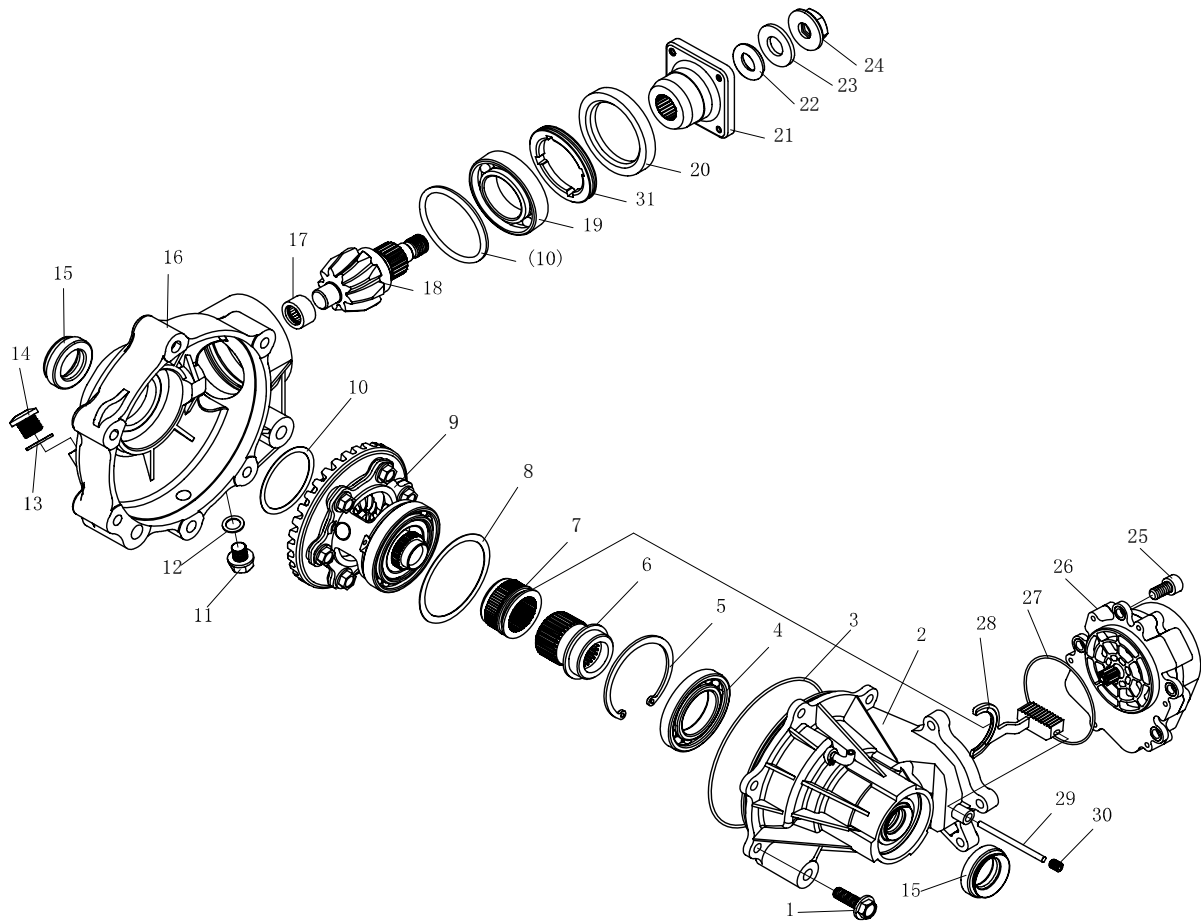

Item	P/N	Qty	Item	P/N	Qty
1	Bolt M8X28	6	17	Bearing F1512	1
2	Differential Gear Case,LH	1	18	Drive Pinion Gear	1
3	O-ring 141X24	1	19	Bearing 6007	1
4	Bearing 16007	1	20	Oil Seal 48X65X9	1
5	Circlip 62	1	21	Coupler	1
6	Driver Clutch Cover	1	22	O-ring 14X6.8	1
7	Driver Clutch	1	23	Nut Washer	1
8	Shim 83X71	1-2	24	Nut M14X1.5	1
9	Differential Gear Assy	1	25	Screw M8X20	4
10	Shim 61X48	2-4	26	Gear Motor	1
11	Drain Bolt M10X1.25	1	27	O-ring 81.2X1.9	1
12	Washer 10,Drain Bolt	1	28	Shift Fork Rack	1
13	Washer 14,Fill Bolt	1	29	Stopper Shaft	1
14	Bolt M14X1.25	1	30	Screw M8X10	1
15	Oil Seal 24X38X8	2	31	Retainer M64X1.5X7	1
16	Differential Gear Case,RH	1	32		

Bearing Disassembly

a Disassemble needle bearing 55BTM6720 as shown when necessary.

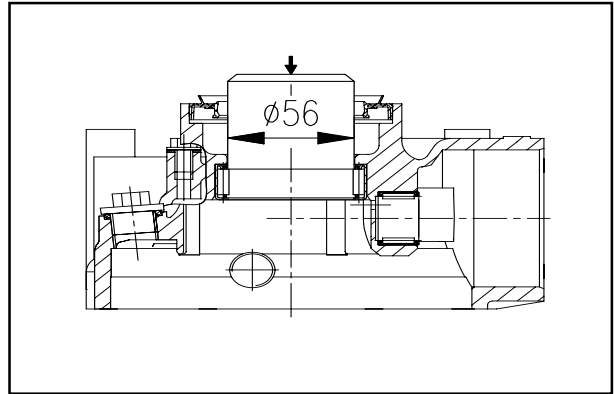

b When replacing needle bearing NA5903, rear gearcase should be heated to 150°C before replacement.

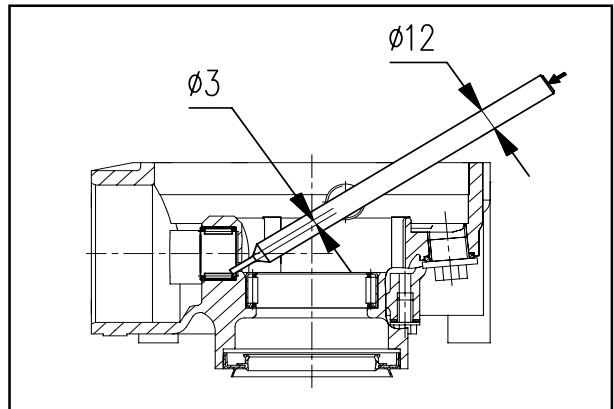

Rear Gearcase Inspection after Disassembly

- Check if there is damage or cracks on the rear gear case and the condition of bearing seats. Replace if necessary.
- Check rear gearcase bearing free play, rotation, bearing cage, steel balls, needles conditions. Replace if necessary (Using special tools).
- Check teeth of gearcase drive pinion gear and ring gear. Replace if necessary.
- Check if oil seal lips and O-ring shape are normal. Replace if necessary.
- Check cylindrical surface that contacts oil seal lips. Replace if necessary.
- Check gearcase inside and outside splines for wears. Replace if necessary.
- Check other parts. Replace if necessary.

Rear Gearcase Assembly and Adjustment

● Illustration

Tightening Torque	
Item "1"	40N•m
Item "2"	25N•m
Item "12"	70N•m
Item "15"	25N•m
Item "20"	70N•m
Item "31"	16N•m
Bolt	25N•m
Bolt	25N•m

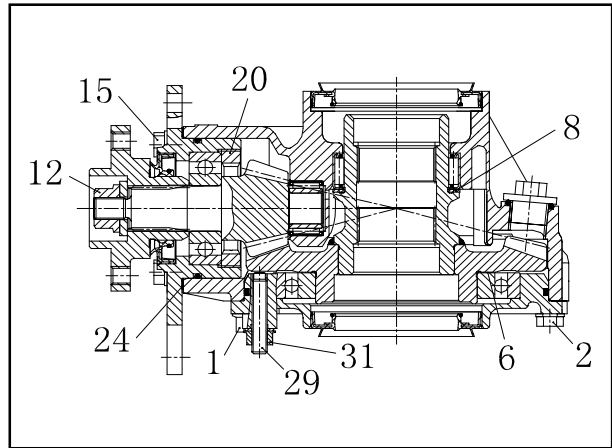

Use threadlocker for Item "29" assembly.

● Assembly and gear lash adjustment between drive pinion gear and ring gear of rear gearcase.

a Adjust installation gear lash by choosing "24" washer.

b Adjust gear lash by choosing "6" washer.

c Check tooth contact between drive pinion gear and ring gear by coloring.

d Measure installation gear lash between drive pinion gear and ring gear as illustrated: Install gear lash measurement tool no. 1, locking bolt (M14X1.25X60) no. 2. Using a dial gauge, make sure the measuring point is 22mm. Turn gear lash measurement tool from engagement to engagement.

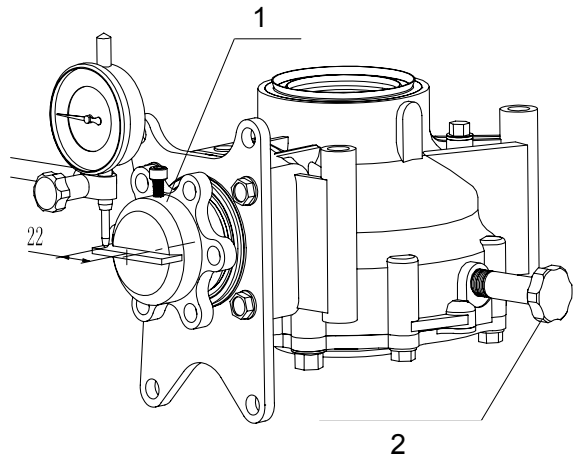

Standard: 0.1~0.2

e Keep the axial gear lash within 0.1~0.2 by choosing washer "8" .

Washer "6"	0.2 0.3 0.4
------------	-------------

Washer "8"	1.0 1.2 1.4 1.6 1.8
------------	---------------------

Washer "24"	0.4 0.5 0.6
-------------	-------------

14 FRONT DIFFERENTIAL/REAR GEARCASE

f Adjust item "29" as illustrated, and make sure the distance between its end and back of the ring gear is 0.3~0.6. Tighten item "31".

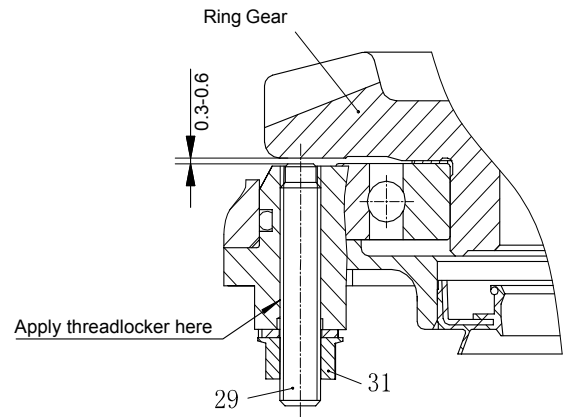

Charging System.....	15-2
Starting System.....	15-4
Electronic Fuel Injection (EFI) System.....	15-8
1. EFI Structure.....	15-8
2. EFI Maintenance Notice.....	15-9
3. EFI Service Tools.....	15-10
4. EFI Components and Function.....	15-12
ECU.....	15-12
Throttle Body.....	15-13
T-MAP Sensor.....	15-14
Coolant Temperature Sensor.....	15-16
Oxygen Sensor.....	15-17
CPS.....	15-18
Speed Sensor.....	15-19
Gear Position Sensor.....	15-20
Fuel Pump.....	15-21
Fuel Injector.....	15-22
Idle Air Control Valve.....	15-23
Ignition Coil.....	15-24
5. EFI Self-diagnosis.....	15-25
MIL.....	15-25
PDA.....	15-26
Trouble Code.....	15-27
Appendix: EFI wiring diagram, starting wiring diagram, CF800-2 wiring diagram	

△ CHARGING SYSTEM

Charging Circuit

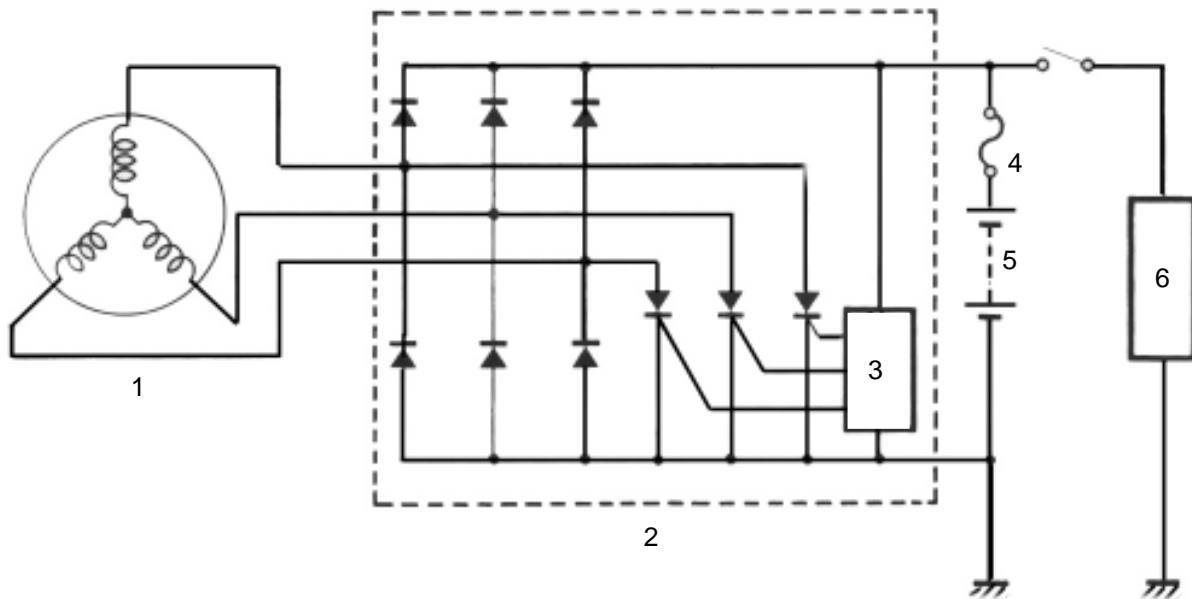

1.Magneto 2.Voltage Regulator/Rectifier 3.Voltage Stablizing 4.Fuse 5.Battery 6.Load

Magneto Coil Resistance

- Measure 3-phase magneto stator coil resistance;
- If the resistance is out of specification,replace with a new stator;
- Check for the insulation between stator coil and core.

Turn multimeter to **1X10 Ω**

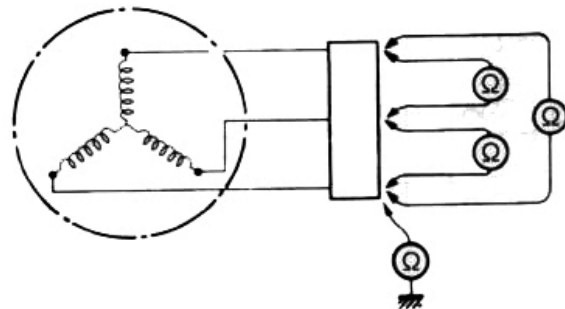

MAG Coil Resistance : **0.5-1.5 Ω**

(**Yellow-Yellow**)

Resistance between Stator Coil and Core: $\infty \Omega$

(**Yellow-Ground**)

MAG Non-loaded Performance

- Start the engine and allow it run at 5000r/min;
- Use multimeter to measure the voltage between 3 output lines.
- Ifthe reading is below specification,replace with a new magneto.

Turn Multimeter to V(AC)

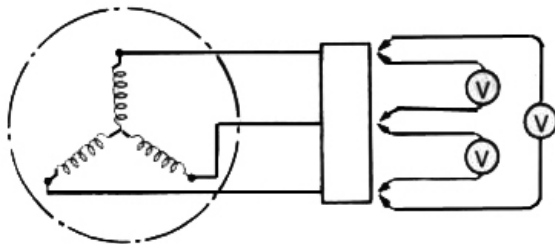

Voltage between Output Lines When MAG Non-loaded:

>200V(AC) at 5000r/min

VOLTAGE REGULATOR/RECTIFIER

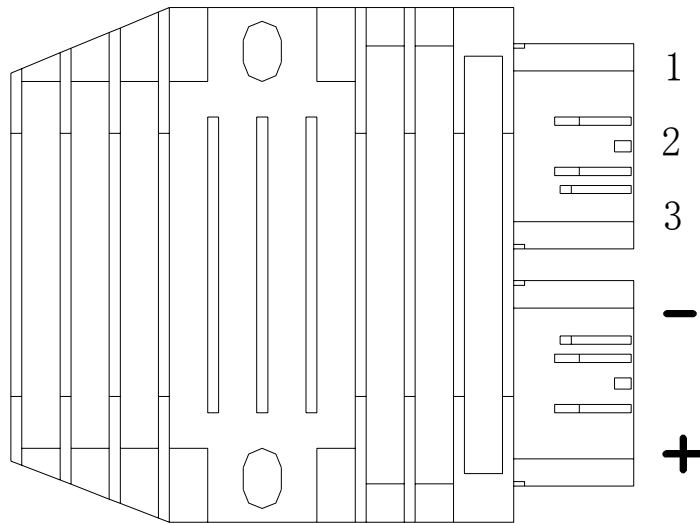

- Connect multimeter between terminals;
- Read resistance;
- If any reading is out of specification, replace with a new regulator.

- After engine running and at the state of battery full charged, if the voltage between positive and negative terminal exceeds 15v or is lower 12v, replace with a new MAG.

Turn multimeter to DIODE.

NOTE:

If multimeter reads below 1.4v when probes unconnected, replace its battery.

		(+) (+)				
		1	2	3	(-)	(+)
(-)	1	∞	∞	∞	400-500	∞
	2	∞	∞	∞	400-500	∞
	3	∞	∞	∞	400-500	∞
	(-)	∞	∞	∞	400-500	∞
	(+)	400-500	400-500	400-501	750-850	

△ STARTING SYSTEM

Starting Circuit Diagram

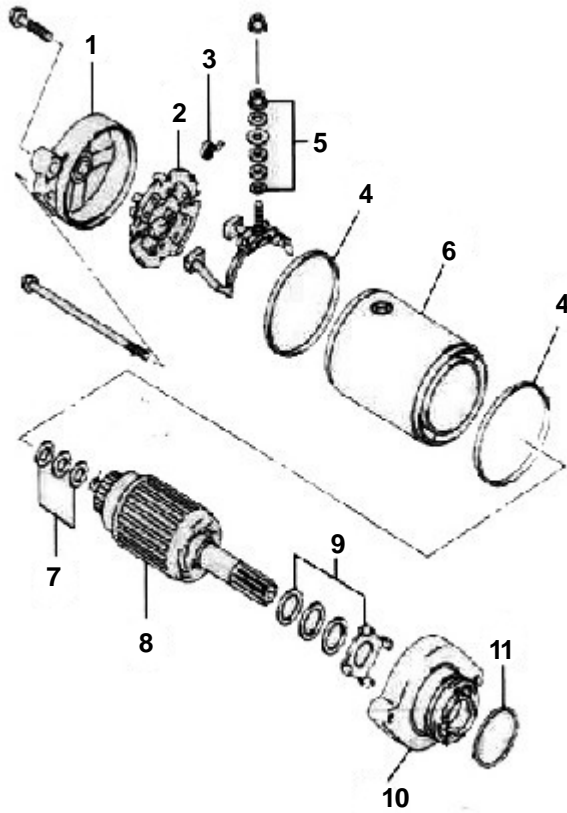

- 1.Outer Cover
- 2.Brush Holder
- 3.Brush Spring
- 4.O-ring
- 5.Brush Terminal
- 6.Main Housing(yoke)
- 7.Washer
- 8.Armature
- 9.Washer
- 10.Cover Inner
- 11.O-ring

BRUSH

- Check brush for damages, cracks.
- If any damages, replace with a new brush.



COMMUTATOR

- Check for color change, damages, wear;
- If any damages, replace with a new commutator;
- If the color changes, polish the commutator surface with sand paper and wipe it up with a clean, dry cloth.
- If over wear, cut a part of insulator B and maintain the distance between A and B as d.



$$d \leq 1.5\text{mm}$$

ARMATURE

Use a multimeter to check the armature coil continuity and the one between coil and the shaft. If armature coil has no continuity or there is continuity between the coil and the shaft, replace the armature with a new one.

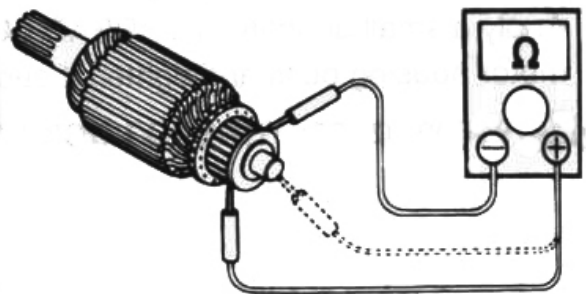

OIL SEAL

Check for damages or leaks. If damages or leaks, replace with a new starter motor.



STARTER RELAY

- Put 12V between positive and negative terminal.
Use multimeter to check if there is continuity between 2 contacts.
- If multimeter clicks, there is continuity between contacts.
- If 12V is removed, no continuity remains between contacts.
- If both above 2 items are ok, it indicates the relay is ok.
Turn multimeter to DIODE.

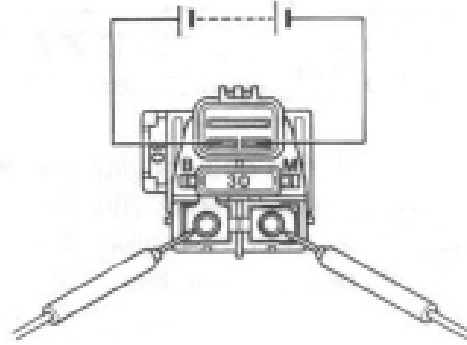

CAUTION:

The voltage loaded between terminals can not exceed 2 mins, otherwise, starter relay may over-heat or burn.

- Use multimeter to measure starter relay coil resistance, if the reading is out of specification, replace a new relay.
- Turn multimeter to $1 \times 10 \Omega$.

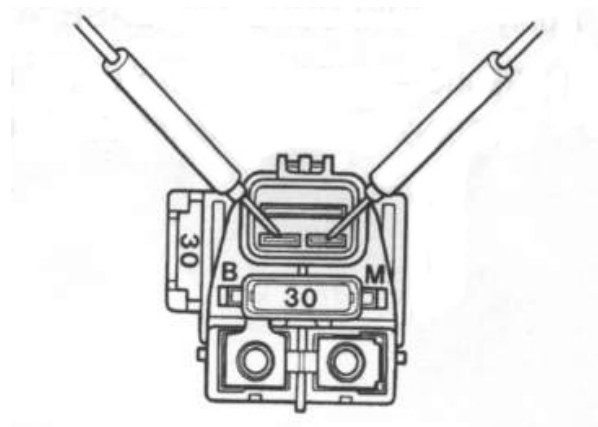

Starter Relay Coil Resistance: $3-5 \Omega$

AUXILIARY STARTER RELAY, FUEL PUMP RELAY

- Put 12V between auxiliary starter relay positive and negative terminal; use multimeter to check the continuity between A and B.
Turn multimeter to DIODE.
- If multimeter clicks, it indicates there is continuity between A and B.
- If 12V is removed, no continuity remains between contacts.
- If both above 2 items are ok, it indicates the relay is ok.
- Turn multimeter to $1 \times 100 \Omega$; measure auxiliary starter relay resistance.
Auxiliary starter relay resistance: $90-100 \Omega$

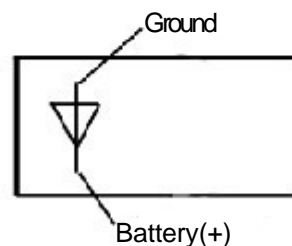
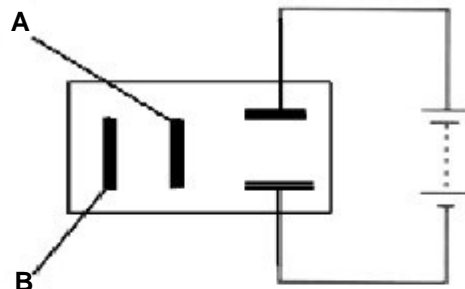

NOTE: At the back of auxiliary starter relay, parallel to diode, it's the relay coil positive terminal.

ENGINE STARTING NOTICE

- Properly route according to starting schematic diagram.
- Before starting, check if all parts are fitted correct; Regarding EFI components connection, refer to EFI section.
- Check air intake system.
- Check fuel supply system; ensure there is no block or leaks.
- Test fuel pressure with fuel pressure gauge.

Pressure in fuel pump outlet: 0.33 ± 0.01 Bar.

- Place the transmission in Neutral.
- Check EFI with PDA for fault; if there is, eliminate the trouble according to DTC (Diagnostic Trouble Code).
- Close the throttle and turn the engine stop switch to "RUN", then push starter switch to run the engine.
- After starting, warm up until idle speed is stable and check it.

NOTE:

If idle speed is unstable or too high, shut off the engine, and then start it.

Idle Speed: 1250 ± 100 rpm.



Fuel Pressure Gauge

△ EFI Structure

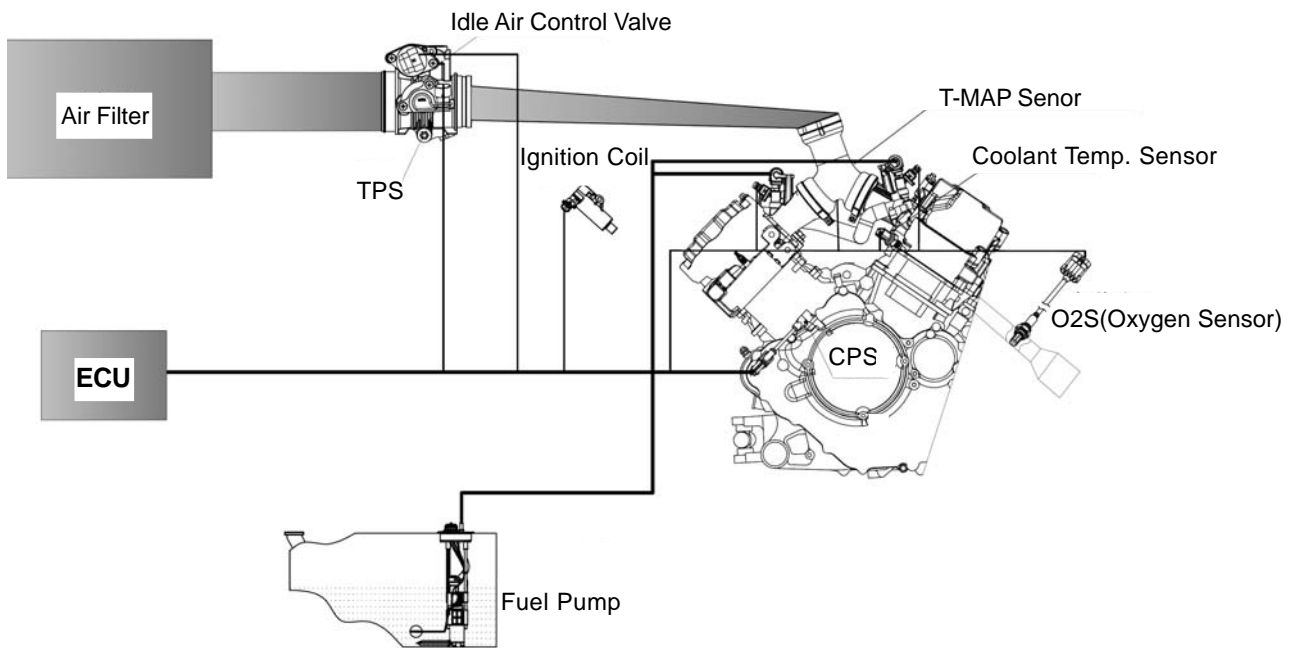

EFI system is composed of three subsystems:

(1) Sensors:

A sensor is a device that measures a physical quantity and converts it into a signal which can be read by an observer or by an instrument. Sensors in EFI system include:

- Throttle Position Sensor(TPS)
- Crankshaft Position Sensor(CPS)
- Coolant Temp. Sensor
- Speed Sensor
- Gear Position Sensor and Reverse Gear Sensor
- Oxygen Sensor
- 4WD/LOCK
- Over-ride Switch

(2) ECU:

Electronic Control Unit, the brain of EFI system, which determines the amount of fuel injection, ignition timing and other parameters a engine needs to keep running by calculating and analysing values provided by sensors.

(3) Actuator:

Execute the EFI instruction. Main actuators include:

- Fuel Pump
- Fuel Injector
- Ignition Coil
- Idle Air Control Valve

EFI System Maintenance Notice

- Always use genuine CFMOTO parts for maintenance, otherwise it can not assure a normal performance to EFI system.
- During the maintenance procedure, never try to break down the EFI components.
- In the course of maintenance, EFI parts must be handled carefully.
- Ignition switch must be shut off before connecting or disconnecting connectors, otherwise, it may cause the EFI parts damage.
- When removing fuel pump from fuel tank, do not energize the fuel pump, otherwise, a spark can cause a fire.
- Fuel pump is not allowed to operate in a dry environment or under water, otherwise, its life would be shortened. Besides, reverse connections between positive and negative terminal of fuel pump is not permitted.
- The fuel pressure in EFI fuel supply system is very high (about 330kPa), accordingly, all fuel lines are high pressure resisting. Even if the engine is not running, the fuel pressure is high. Therefore, do not disassemble the fuel line unless it's necessary. When the fuel line needs to be repaired, release the fuel pressure as follow shows:
Remove fuel pump relay, start the engine and allow it to idle until the engine stalls automatically.
Fuel line removal and fuel filter replacement should be practiced by a professional person in a well-ventilated place.
- If possible, don't do the spark test. If spark test is done unavoidably, try to complete the test as soon as possible. Besides, don't open the throttle, otherwise, a large quantity of unburnt fuel would enter muffler, causing the catalytic converter damage.
- Idle speed is controlled by ECU, so it's unadjustable. The throttle limiter screw has been adjusted by manufacturer before sale, therefore, it's not recommended to adjust it by the user.
- Don't reverse the battery cable connections. This may damage electrical components.
- Never remove the battery cables When the engine is running.
- Always remove cables and electrical control units which are connected with battery terminals.
- Never test the component input and output electric signal by piercing the cable plastic jacket.
- Respect the environment and dispose of the waste left during maintenance.

SERVICE TOOLS



Tool Name:PDA

Function:

Read/clear EFI system trouble codes,observe datastream.



Tool Name:Digital Multimeter

Function:

measure voltage, current and resistance and other parameters in EFI system.



Tool Name:Vaccum Gauge

Function:

Check the manifold for air pressure.



Tool name:Timing Light

Function:

This light is used to check engine ignition timing.



Tool name:Compression Tester

Function :

This tester is used to check cylinder compression,so as to determine if the rings or valves are bad and leaking pressure.



Tool Name:Fuel Pressure Gauge

Function :

This gauge is used to test the fuel pressure,so as to check fuel pump and fuel pressure regulator working conditions.



Tool Name:Fuel Injector Analyser

Function:

This analyser is used to clean and analyse fuel injectors.

EFI COMPONENTS AND FUNCTION

(1)ECU:

ECU pins and function:

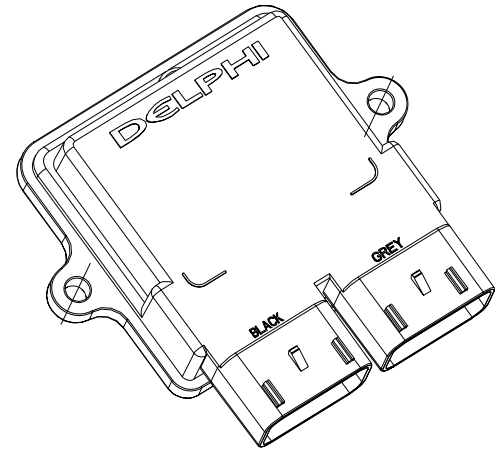

ECU

PINOUT CHART				
J1 CONNECTOR				
PIN#	Description	PIN#	Description	
J1-1	IACVHI/IAV	J1-10	COILB/ESTB	
J1-2	MAGNETO RELAY/CLTL/ESTC	CUT	J1-11	IACALO
J1-3	MIL	J1-12	IACBHI	
J1-4	DEAD BYPASS/O2BHTR/INJC	BATT	J1-13	IACBLO
J1-5	SPARE ANALOG	J1-14	ROLLOVER	
J1-6	TACHOMETER	J1-15	VSS/O2B SENSOR	
J1-7	CANLO	J1-16	DIAG	
J1-8	CANHI	J1-17	FUEL PUMP RE-CIR	
J1-9	GND(POWER)	J1-18	PNSW	
J2 CONNECTOR				
Pin#	Description	Pin#	Description	
J2-1	COILA/ESTA	J2-10	5VRTN	
J2-2	GND(POWER)	J2-11	MAP	
J2-3	KW2000	J2-12	TPS	
J2-4	CRANK VR HI(23XHIFI)	J2-13	CRANK VR LO(23XLOFI)	
J2-5	INJA	J2-14	CLT	
J2-6	INJA	J2-15	IGN	
J2-7	O2A HTR	J2-16	5VREF	
J2-8	IAT-MAT	J2-17	O2A SENSOR	
J2-9	FUEL PUMP RELAY	J2-18	VBATT	

ECU Pin Locations:

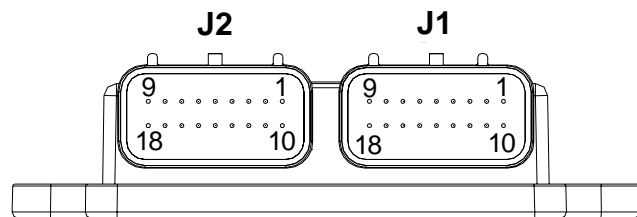

Limit Data:

Item		Value			Unit
		Min	Standard	Max	
Battery Voltage	Operation Normal	9.0	14.0±1	16.0	V
	Function Limited	6.0-9.0		16.0-18.0	V
Withstanded Overvoltage and Time	26.0V	Limited Function Such As Diagnosis		5.0	Min
Working Temp		-40		+70	°C
Storage Temp		-40		+70	°C

- It's not allowed to apply a heavy load on ECU housing, or it may deform and damage ECU.
- Always handle ECU gently. Never drop it, especially on a hard surface.

(2) THROTTLE BODY ASSEMBLY:

Connected between air filter and engine. When throttle lever is applied, the valve butterfly in throttle body would spin at a certain angle. Tps can monitor the position of valve butterfly and send the signal to ECU.

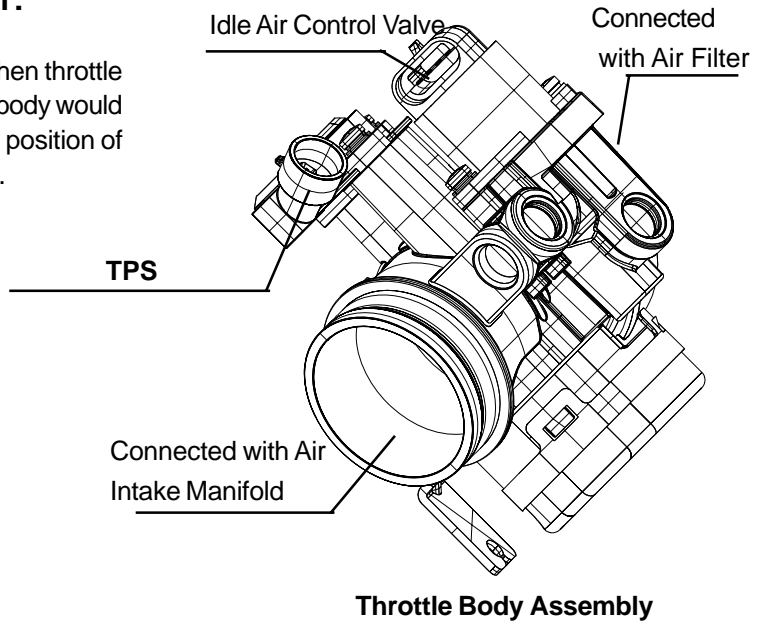

Pins and function:

- 1. Connected to 5V power
- 2. Ground
- 3. Outout voltage signal

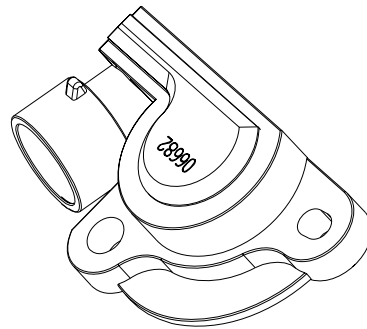
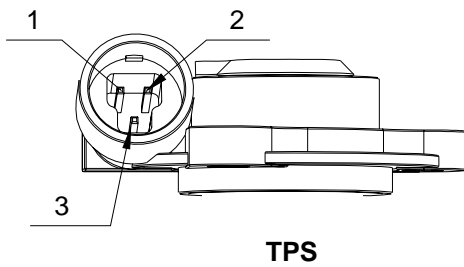

TPS Circuit:

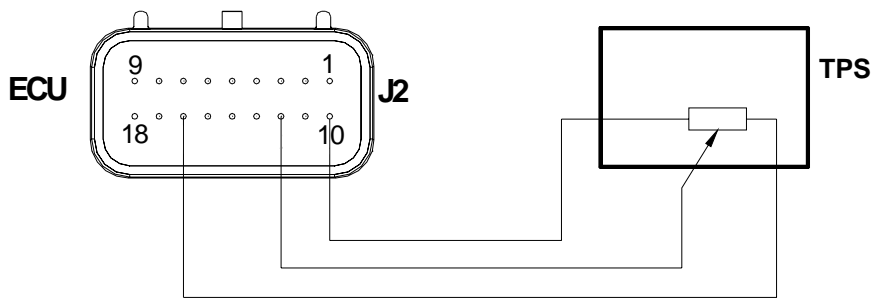

Idle speed limiter screw is not allowed to adjust.

- Idle speed is regulated by ECU.

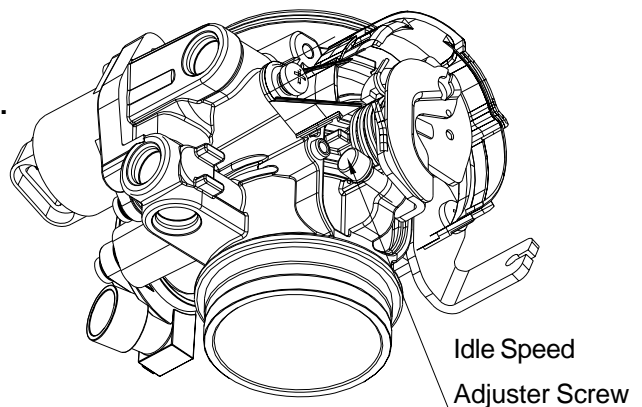

(3)T-MAP SENSOR:

This sensor integrates Inlet Air Temperature Sensor and Manifold Absolute Sensor. It's used to detect both inlet air temperature and manifold absolute pressure, providing ECU the signal of engine load.

Pins and Function:

- 1. Ground
- 2. Connected with 5V power
- 3. Voltage signal output

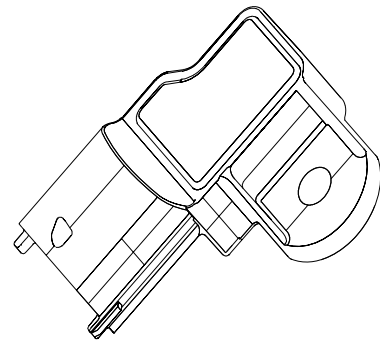
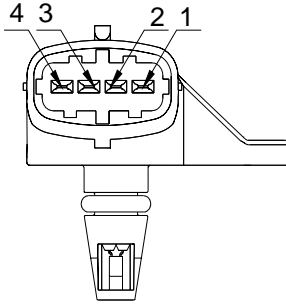

T-MAP Sensor

T-MAP Sensor Circuit:

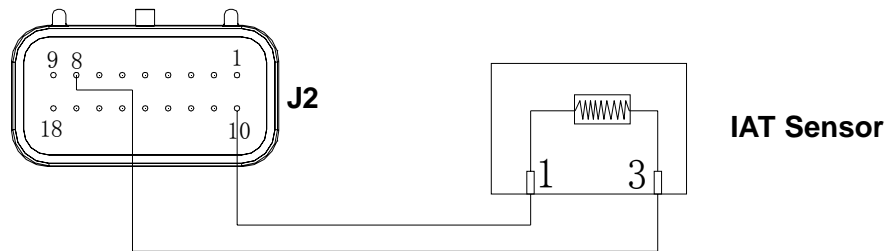
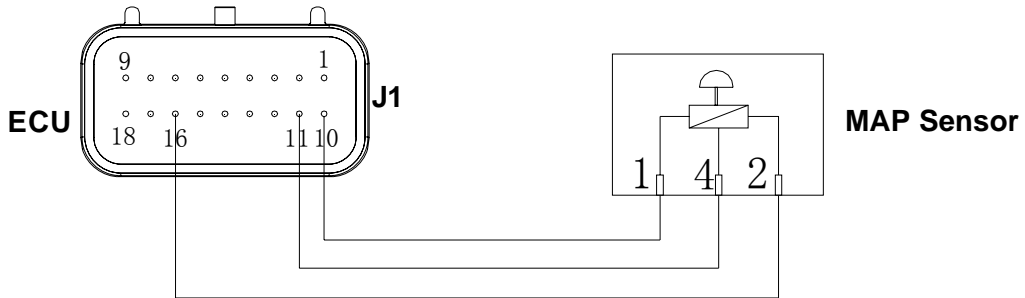

The right figure illustrates the allowed installation angle to avoid condensed water built up in T-MAP sensor, causing pressure sensitive elements damage.

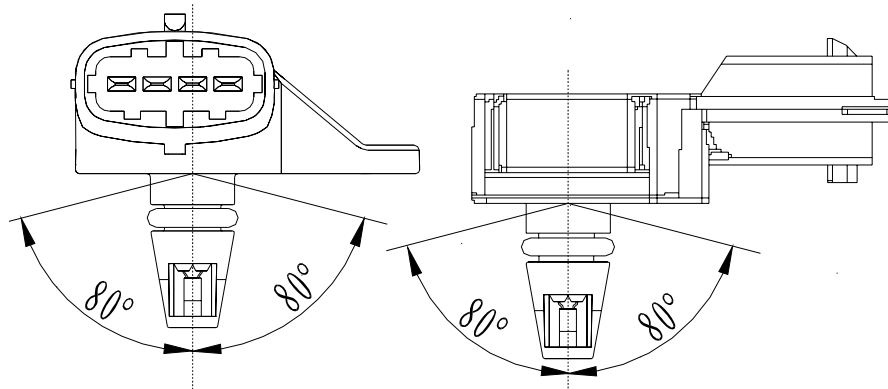

The following figure refers to output voltage-pressure relation.

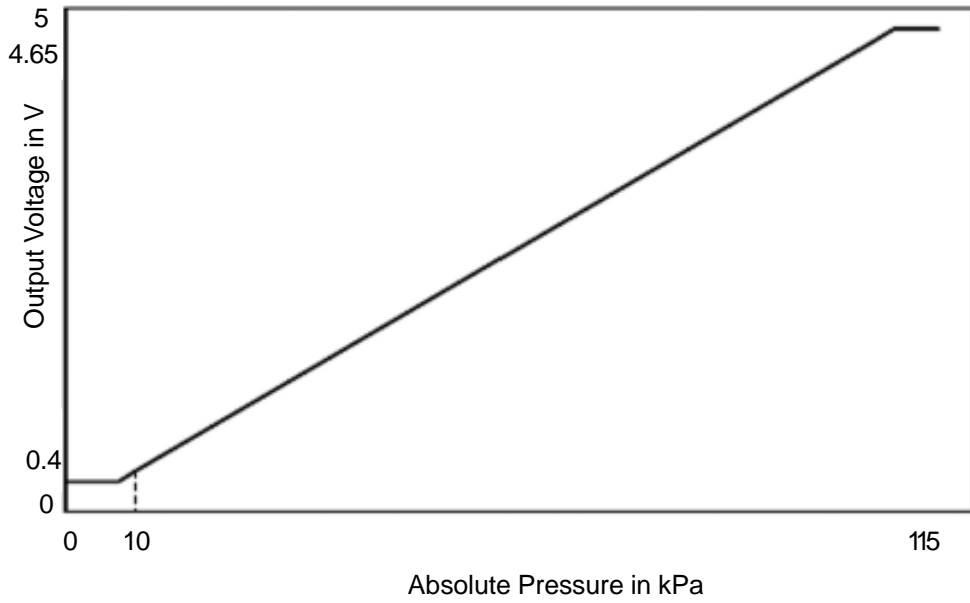

The following chart explains resistance-temperature relation.

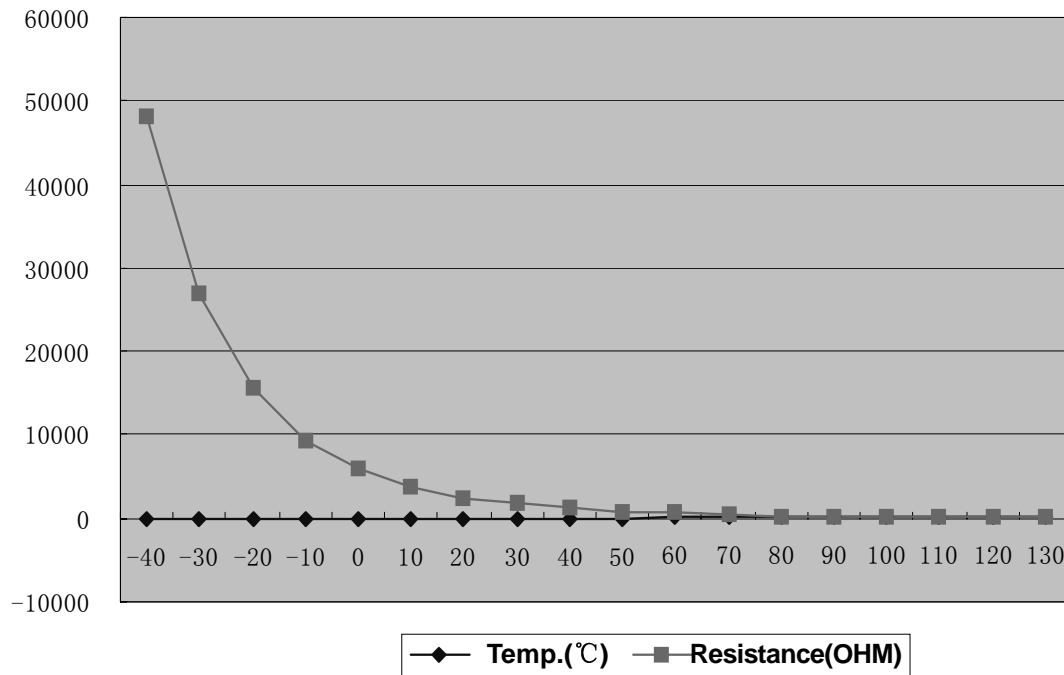

(4)COOLANT TEMPERATURE SENSOR (CTS):

This sensor is a negative temperature coefficient(NTC) thermistance,whose resistance increases with the temperature of coolant decreases.It outputs 2 set of coefficients,one is for ECU to monitor the temperature of coolant,the other is for meter dispaly.

A and **C** consists of one group,which provids signal for ECU.

B and **threaded portion** consists of one group,which provides sigal for coolant temperature gauge.

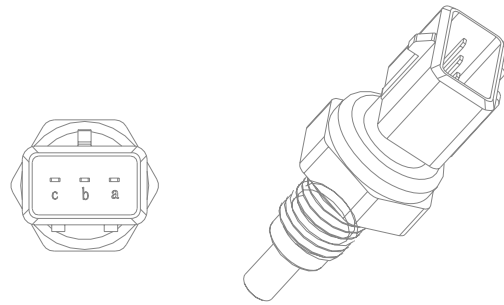

Coolant Temperature Sensor

Coolant Temperature Sensor Circuit:

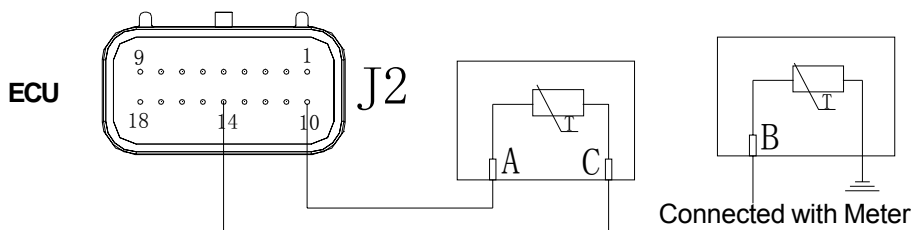

The right chart explains pin B and threaded portion-coolant temperature relation.

Meter Channel Resistance(b-Threaded Portion)	
Temp.(°C)	Resistance(Ω)
45	265.0-323.0
80	74.6-90.6
115	25.7-31.7

The right chart explains pin A,C-coolant temperature relation. The signal is for ECU.

ECU Channel Resistance(a-c)	
Temp.(°C)	Resistance(Ω)
-25	38,583
0	9,399
25	2,795
80	334
115	115.7

(5) OXYGEN SENSOR:

This sensor is used in closed-loop feedback-controlled fuel injection to improve the air-to-fuel ratio accuracy and control the emission.

It's located in the exhaust stream to measure the amount of oxygen in exhaust and send the signal to ECU, which can revise the fuel injector output, so as to reduce the amounts of both unburnt fuel and oxides of nitrogen entering the atmosphere.

Pins and Function:

1. Connected with positive terminal, heating power (white)
2. Connected with negative terminal, heating power (white)
3. Connected with negative terminal, signal output (grey)
4. Connected with positive terminal, signal output (black)

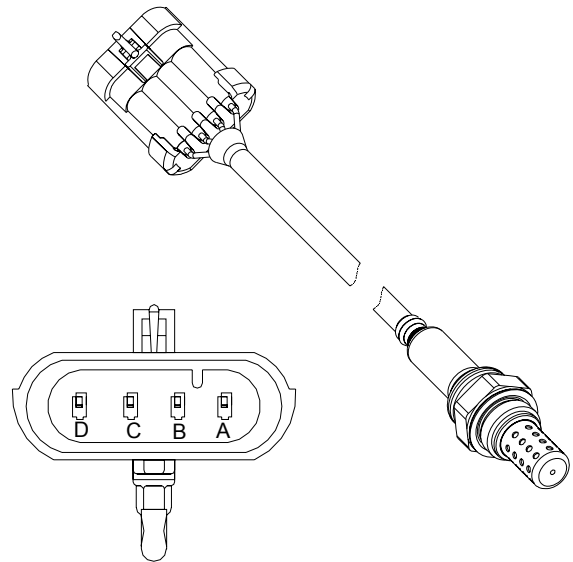

Oxygen Sensor Circuit:

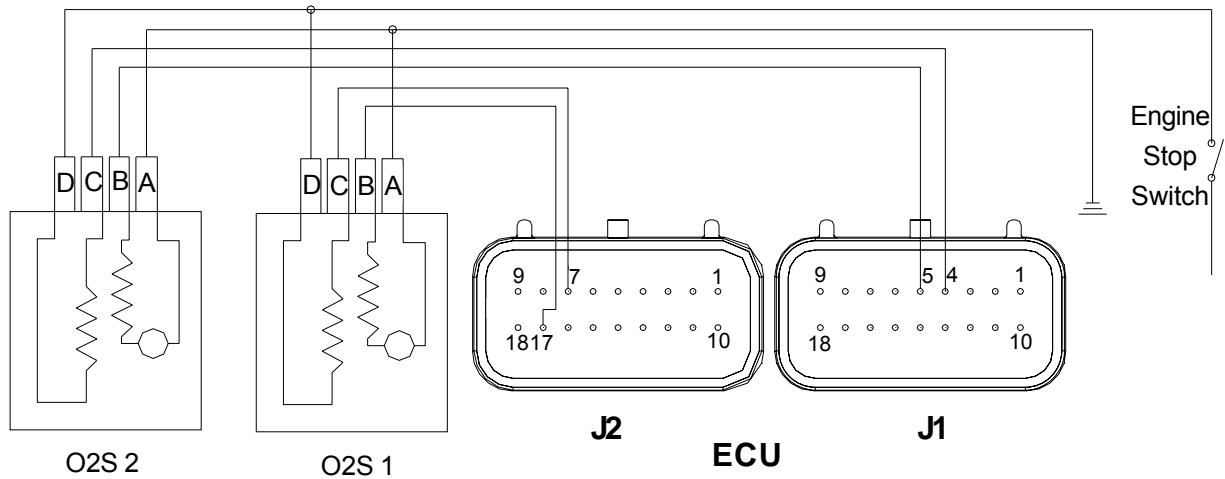

The following table explains the oxygen sensor working parameters.

Parameter	New oxygen sensor		After 500 hours bench test	
	350°C	850°C	350°C	850°C
Exhaust temp. at a certain duty ratio	350°C	850°C	350°C	850°C
Sensor voltage (mv) when $\lambda=0.97$ ($Co=1\%$)	840±70	710±70	840±70	710±70
Sensor voltage (mv) when $\lambda=1.10$	20±50	55±30	20±50	40±40
Sensor inner resistance	≅1.0	≅0.1	≅1.5	≅0.3
Response time(ms)(600mv-300mv)	≅150	≅150	≅300	≅200
Response time(ms)(300mv-600mv)	≅150	≅150	≅300	≅200

(6) CRANKSHAFT POSITION SENSOR (CPS):

Detects the rate at which the crankshaft is spinning and provides the signal for ECU to determine ignition and fuel injection.

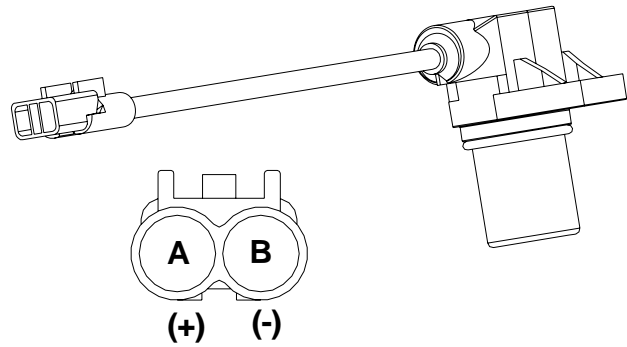

CPS Circuit:

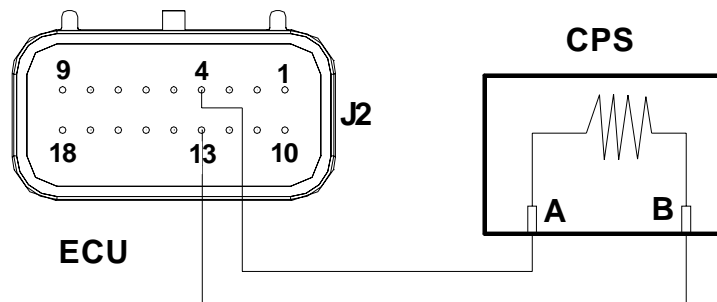

CPS Resistance:

- Set multimeter to **1X2K Ω** range;
CPS resistance: $950 \pm 50 \Omega$ (20°C)
- If the CPS resistance reading is out of specification above, replace.

Test CPS Peak Voltage

- Connect multimeter and peak voltage adapter as right wiring diagram illustrates;

+Probe: Green Lead

- Probe: Blue Lead

NOTE:

When using peak voltage adapter, refer to some instructions.

- Set multimeter to **V** range;
- Place the transmission in **N** and turn the ignition switch to **"ON"**;
- Push starter switch and allow the engine to run for seconds, then test CPS peak voltage;
- Repeat above procedure and get the highest CPS peak voltage;

CPS peak voltage : $\geq 2V$ (300rpm)

- If the CPS peak voltage reading is out of above specification, replace.

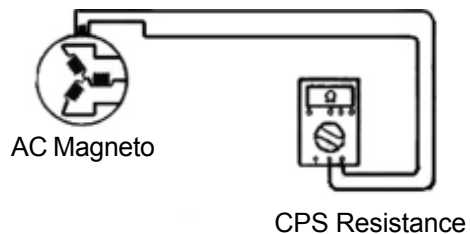

AC Magneto

CPS Resistance

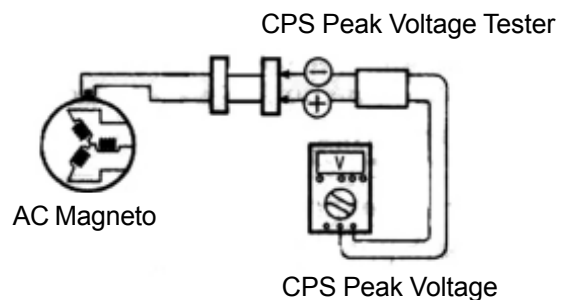

AC Magneto

CPS Peak Voltage Tester

CPS Peak Voltage

(7) SPEED SENSOR:

This sensor is used to detect the rotating speed of the engine output shaft and provide the signal for ECU to determine the vehicle speed. It belongs to Hall effect sensor, that varies its output voltage in response to a magnetic field.

Pins and Function:

1. Ground
2. Output voltage signal (>80% input power voltage)
3. Power+DC12V

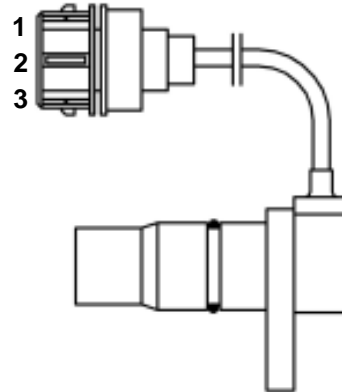

Speed Sensor Exterior

The right figure refers to speed sensor wiring:

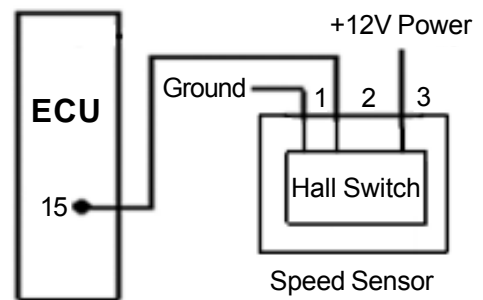

Speed Sensor Test:

- Ground pin 1 and connect pin 3 with +12V power;
- Fix a gear 2.5mm away from a speed sensor as the right figure illustrates;
- Turn multimeter to DCV range;
- Slowly turn the gear and measure the voltage between pin 2 and pin 3 to determine that if the reading varies from 0V-12V;
- If the reading doesn't vary, that indicates the sensor is defective and needs to be replaced.

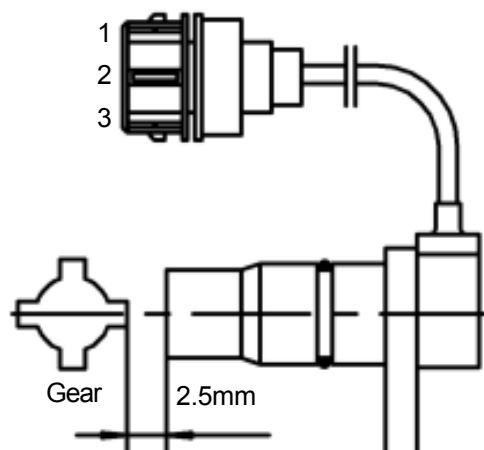

(8) GEAR POSITION SENSOR:

This sensor is used to provide the gear position signal for meter display.

Pins and Function:

Yellow/Blue-L(Low Gear)

Orange/Blue-H(High Gear)

Yellow/Black-P(Park Gear)

White/Yellow-N(Neutral)

Sky Blue/White-R (Reverse Gear)

● When each pin at a certain gear position, there is continuity between this pin and engine. Otherwise, no continuity.

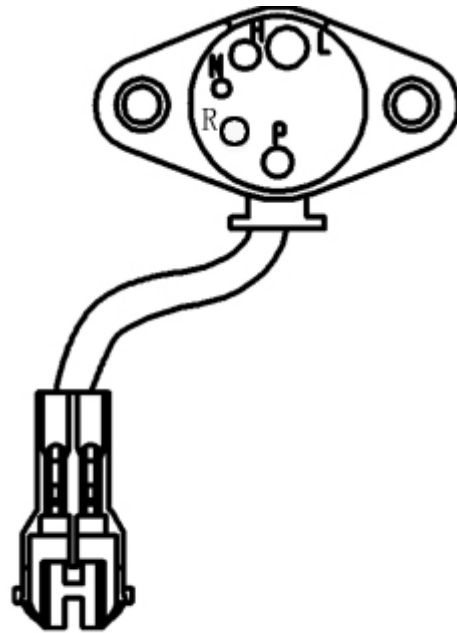

Gear Position Sensor

(10) CAUTION when driving in reverse

● When driving in reverse, gear position sensor sends the reverse signal to ECU and meter. ECU would limit the vehicle speed in response to the reverse signal.

(10) FUEL PUMP ASSEMBLY:

This fuel pump assembly includes fuel pump, plastic support, preliminary filter, fine filter and pressure regulator. It supplies fuel for engine under a certain pressure and flow.

Pins and Function:

1. Blue (Ground)
2. Red (Connected with fuel pump relay output terminal)

Parameters:

Pressure regulator opening pressure: $0.33 \pm 0.01 \text{ MPa}$

Flow: $>35 \text{ L/h}$

- This fuel pump is located in fuel tank;
- Don't operate the fuel pump in dry condition in order to prevent damage.
- Always handle the fuel pump gently. Never drop the fuel pump, especially on a hard surface. Such a shock to pump can damage it.

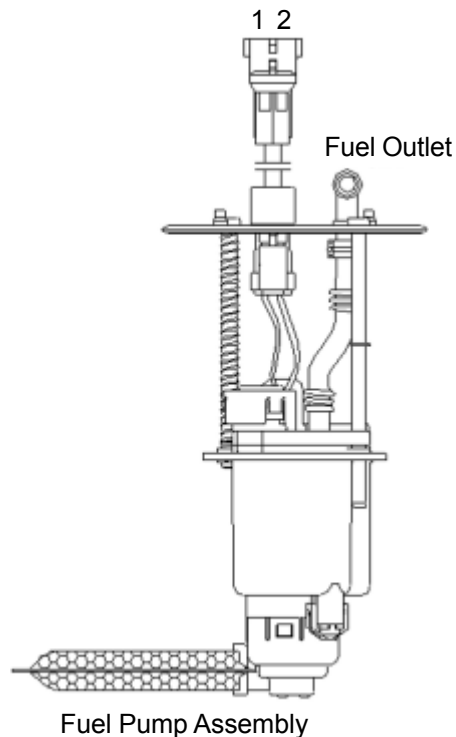

Fuel Pump Wiring:

● Battery supplies power for fuel pump assembly via fuel pump relay, which connects the fuel pump circuit only with the engine started.

Fuel Pressure Test:

- Connect the fuel pressure gauge with fuel outlet and tighten the joint with a clamp to prevent fuel leaks;
- Route according to the right circuit;
- Turn both ignition switch engine stop switch on;
- At this moment, fuel pump will operate for 5 seconds. After the fuel pump stops running, fuel pressure should be in specification, otherwise replace it;
- After the engine stops running, 0.25 MPa fuel pressure should be kept for more than 5 minutes, otherwise replace the fuel pump;

Pressure Relief in Fuel System:

In an EFI model, the pressure in fuel system is very high, so all the line is high pressure resistant. Even though the engine is not started, the pressure in fuel system remains high. Therefore, it's not recommended to remove fuel lines before pressure relief.

Follow the procedure below to perform pressure relief:

Remove fuel pump relay. Start the engine and allow it to idle until the engine stops automatically.

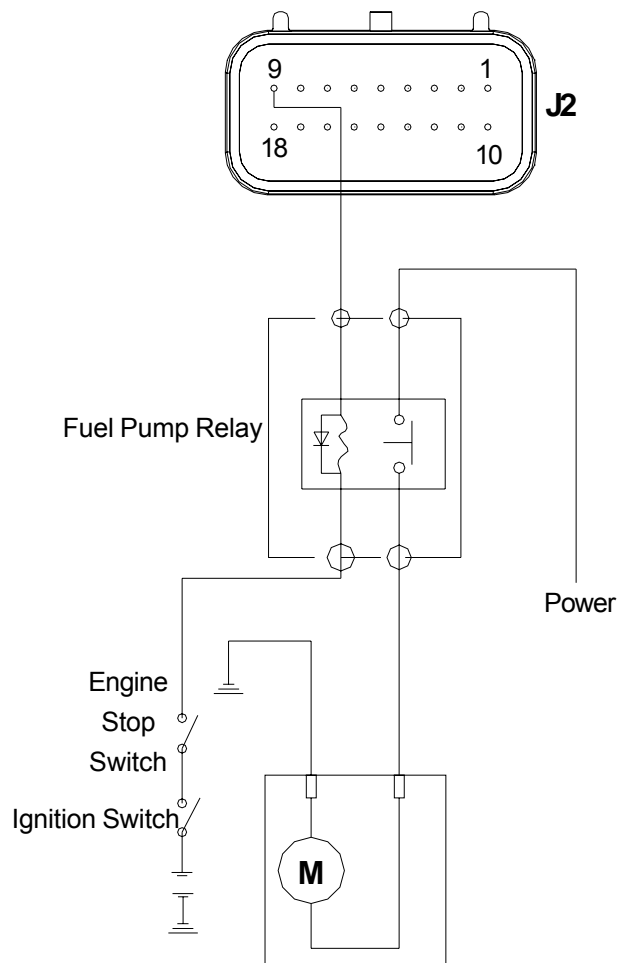

(11) FUEL INJECTOR:

One end of fuel injector mounts into fuel injector seat, and the other end attaches to the injector cap, which connects with a fuel line. Fuel injector is controlled by ECU to inject fuel at stated time into the engine.

This injector nozzle is a 4-hole style. Don't turn injector after the joint between injector and injector cap is installed.

Pins and Function:

- Connector with the mark "+": connected with fuel pump relay output terminal.
- Connector without mark: connected with ECU pin 14.

Fuel Injector Resistance: $12 \pm 1 \Omega$ (20°C)

Connected with Injector Cap

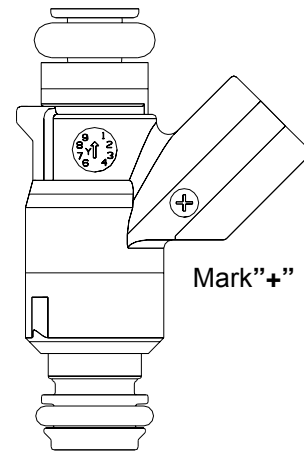

Connected with Injector Seat

Fuel Injector Exterior

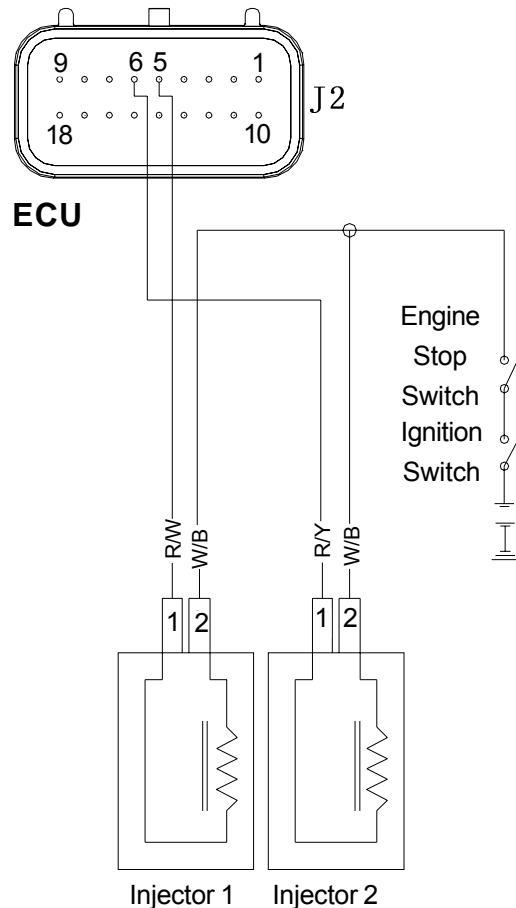

Fuel Injector Circuit:

Fuel Injector Installation:

- Install fuel injector manually. Never knock fuel injector with a hammer.
- When removing and installing fuel injector, the o-rings on both ends must be replaced;
- Perform pressure relief before fuel injector removal if necessary;
- Test the fuel injector sealing after installation to ensure no leaks.

(12) IDLE AIR CONTROL VALVE:

IACV is used to control the air flow of by-pass. ECU calculates the engine load and controls IACV through electrical pulse duration and frequency (commonly known as duty ratio). IACV allows different air flows passed through under different pressure differences. Therefore, it should be connected properly, otherwise, idle speed may be incorrect. When there is no electrical pulse, IACV would be closed.

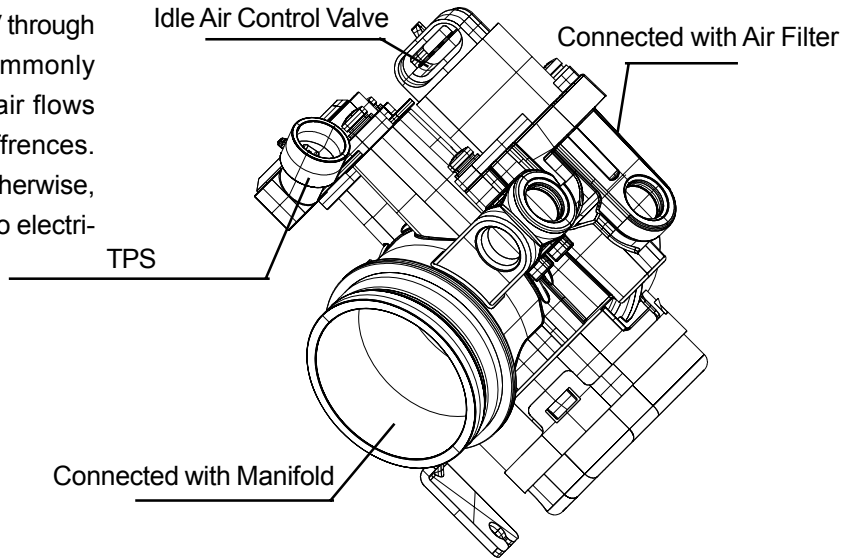

Pins and Function:

1. Pin A: IACBLO-ECU J1-13;
2. Pin B: IACBHI-ECU J1-12;
3. Pin C: IACALO-ECU J1-11;
4. Pin D: IACAHI/IAV-ECU J1-1;

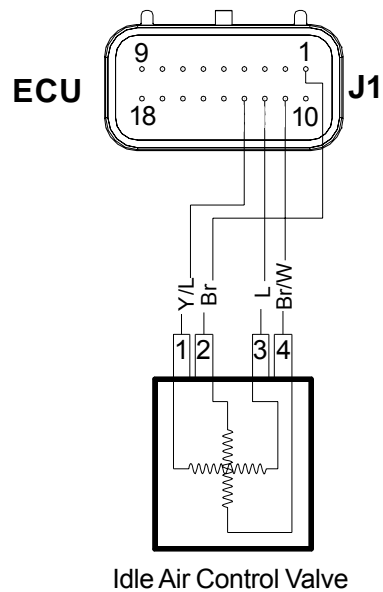

Idle Air Control Valve Circuit:

Idle Air Control Valve Parameters:

Item	Value			Unit
	Min	Standard	Max	
Rated Voltage		13.5		V
Resistance(+20°C)		16		Ω
Rated Current		0.85		A
Control Pulse Frequency			30	Hz
Standard Control Pulse Width		≈8		ms
Air Flow(When Pressure Difference=700mbr, Duty Ratio=100%)		5.0		m ³ /h

(13)IGNITION COIL

Ignition coil transforms the low voltage of primary coil to high voltage of secondary coil needed to spark the spark plug and ignite the mixture of air and fuel in cylinder.

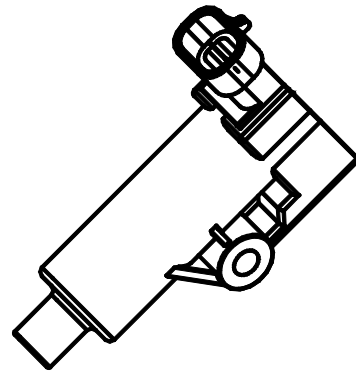

Connected with High Tension Lead

Pins and Function:

1. Ignition coil (-) of cylinder 1 connected with pin 1, ECU J2;
1. Ignition coil (+) of cylinder 1 connected with battery(+);
3. Ignition coil (-) of cylinder 2 connected with pin 10, ECU J1;
4. Ignition coil (+) of cylinder 2 connected with battery(+);

Ignition Coil Circuit:

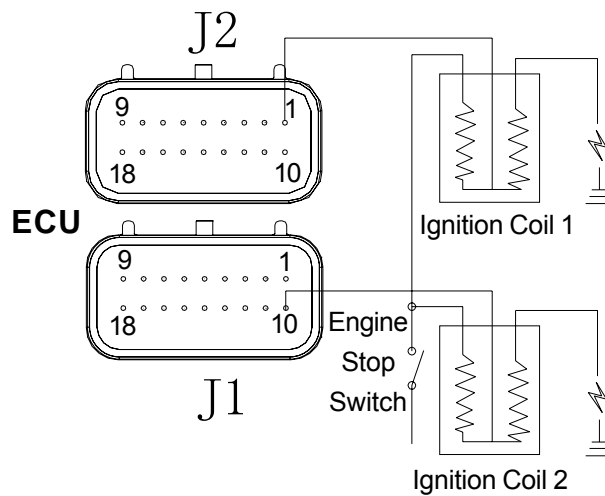

Secondary Ignition Voltage Test:

- Connect the engine according to EFI wiring diagram;
- Connect the peak voltage tester according to the right diagram;
- Start the engine;
- Secondary ignition voltage should be >15000V.

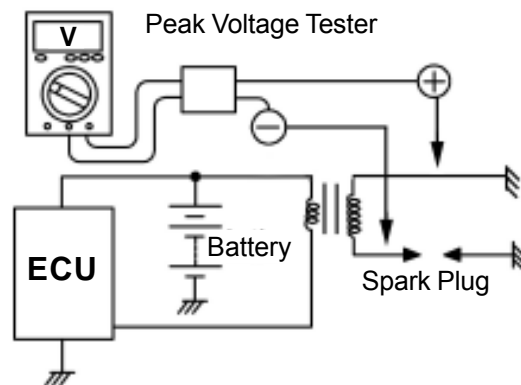

Ignition Coil Parameters:

Item	Value			Unit	
	Min	Standard	Max		
Stated Voltage		14		V	
Operating Voltage	6		16.5	V	
Resistance (20-25°C)	Primary Winding Resistance	0.74	0.76	0.78	Ω
	Secondary Winding Resistance	10.1	10.6	11.1	KΩ
Primary Current		7		A	

(14)EFI SELF-DIAGNOSIS:

ECU constantly monitors sensors,actuators,circuits,MIL and battery voltage,etc,even itself.It also tests sensors output signal,actuator drive signal and inner signal(such as closed-loop control,coolant temp. signal,idle speed control and battery voltage control,etc for reliability).If any malfunction or suspectable signal found, ECU would record the fault information in RAM.

Fault information comes in form of fault codes,which are then displayed on PDA, in sequence of which fault comes first.

Fault can be divided into “steady fault” and “occasional fault” (such as a fault caused by harness short or loose connection.)

PDA or MIL can be used to locate the part in trouble immediately after fault happens.

(1)MIL(or FI Indicator):

MIL is a light-emitting diode and located on instrument panel. It indicates different fault codes through the flashes in different frequency.

MIL Circuit:The current in pin 3,ECU J1 should be less than0.1A.

MIL Flash Principles:

(1):Turn ignition switch on and depress kill switch.Don't run the engine.If no malfunction happens.

MIL turns on for 5 seconds,then turns off.

(2):Turn ignition switch on and depress kill switch.Don't run the engine.If malfunction happens.

MIL turns on for 5 seconds and turns off.Then MIL flashes to indicate a fault code:

The interval between fault codes is 3.5s,between digits is 1.2s,and a flash lasts for 0.4s as well as the interval between 2 flashes.

MIL flashes 10 times to indicate 0.From 1-9,how much it counts,how many times MIL flashes.

Take fault codes P0117 and P0232 for example:

MIL lights up for 5 seconds → turns off and lasts for 3.5s → flashes for 10 times(the frequency is 0.4s) → turns off and lasts for 1.2s → flashes once → turns off and lasts for 1.2s → flashes once → turns off and lasts for 1.2s → flashes for 7 times → turns off and lasts for 3.5s → flashes for 10 times → turns off and lasts for 1.2s → flashes for 2 times → turns off and lasts for 1.2s → flashes for 3 times → turns off and lasts for 1.2s → flashes for 2 times.

(3):Turn ignition switch on and run the engine.Malfunction happens.

MIL lights up until malfunction disappears.

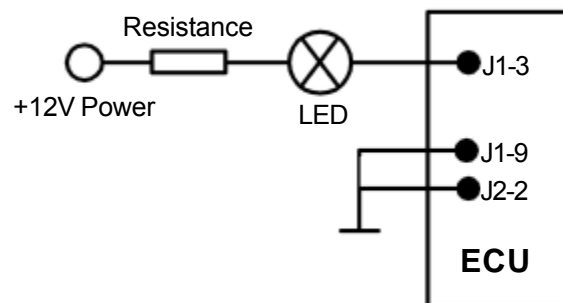

(2)PDA:PDA has 3 pins-power,ground wire and data cable K.Thses pins are connected with related ECU pins.

The right photoe refers to operation panel of PDA.When it comes to detailed keys function,refer to PDA instruction book.

Pins and Function:

- 1.Connected with pin 3,ECU J2;
- 2.Ground
- 3.Connected with +12V power

Keys and Function:

LH Key:Page up

UP Key:Scroll Up

RH Key:Page Down

Down Key:Scroll Down

OK Key:Entrance

EXIT Key:Exit

PDA Function:

(1)Version Infomation Display

PDA can display engine,ECU hardware and soft ware infomation.

(2)Fault Display

PDA monitors IAP sensor,IAT sensor,coolant temperature sensor,TPS,O2S,O2S heater circuit,air-to-fuel ratio revision,fuel injector,fuel pump relay,CPS,speed signal,idle speed,idle air control valve,system voltage, ECU,FI indicator and displays the fault code.

(3)Engine Data stream Display

PDA can display battery voltage,RPM,desired idle speed,vehicle speed,coolant temperature,coolant temperature sensor signal voltage,inlet air temperature,IAT sensor signal voltage,inlet air pressure,inlet air flow, IACV target position,TPS signal voltage,throttle body position,throttle body relative position,canister duty, charging time,FI pulse width,park advance angle,O2S voltage,engine relative load,cansiter load,IACV position,atmospheric pressure,altitude multiplier,engine operation time.

(4)EFI Status Display

Starter switch,main relay,fuel pump relay,idle speed,idle speed,full load status,deceleration activation, acceleration activation,FI close loop activation,lambada control activation,canister control valve activation, MIL status.

(5)Actuator Test Function

MIL,fuel pump,IACV,canister control valve,ignition,fuel injection.

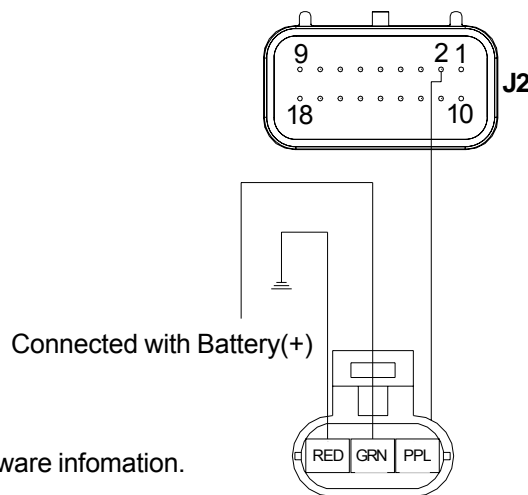

FAULT CODE TABLE:

P0107	MAP Circuit Low Voltage or Open	MAP-Manifold Absolute Pressure
P0108	MAP Circuit High Voltage	
P0112	IAT Circuit Low Voltage	IAT-Inlet Air Temperature
P0113	IAT Circuit High Voltage or Open	
P0117	Coolant/Oil Temperature Sensor Circuit Low Voltage	
P0118	Coolant/Oil Temperature Sensor Circuit High Voltage or Open	
P0122	TPS Circuit Low Voltage or Open	TPS-Throttle Body Position
P0123	TPS Circuit High Voltage	
P0131	O2S 1 Circuit Low Voltage	O2S-Oxygen Sensor
P0132	O2S 1 Circuit High Voltage	
P0032	O2S 1 Heater Circuit High Voltage	
P0031	O2S 1 Heater Circuit Low Voltage	
P0201	Injector 1 Circuit Malfunction	
P0202	Injector 2 Circuit Malfunction	
P0230	FPR Coil Circuit Low Voltage or Open	FPR-Fuel Pump Relay
P0231	FPR Coil Circuit Low Voltage or Open	
P0232	FPR Coil Circuit High Voltage	
P0336	CKP Sensor Noisy Signal	CKP-Crankshaft Position
P0337	CKP Sensor No Signal	
P0351	Cylinder 1 Ignition Coil Malfunction	
P0352	Cylinder 2 Ignition Coil Malfunction	
P0505	Idle Speed Control Error	
P0562	System Voltage Low	
P0563	System Voltage High	
P0650	MIL Circuit Malfunction	MIL-Malfunction Indicator Light
P1693	Tachometer Circuit Low Voltage	
P1694	Tachometer Circuit High Voltage	
P0137	O2S 2 Circuit Low Voltage	
P0138	O2S 2 Circuit High Voltage	
P0038	O2S Heater 2 Circuit High Voltage	
P0037	O2S Heater 2 Circuit Low Voltage	
P0500	VSS No Signal	VSS-Vehicle Speed Sensor
P0850	Park Neutral Switch Error	
P0445	CCP short to high	
P0444	CCP short to low/open	

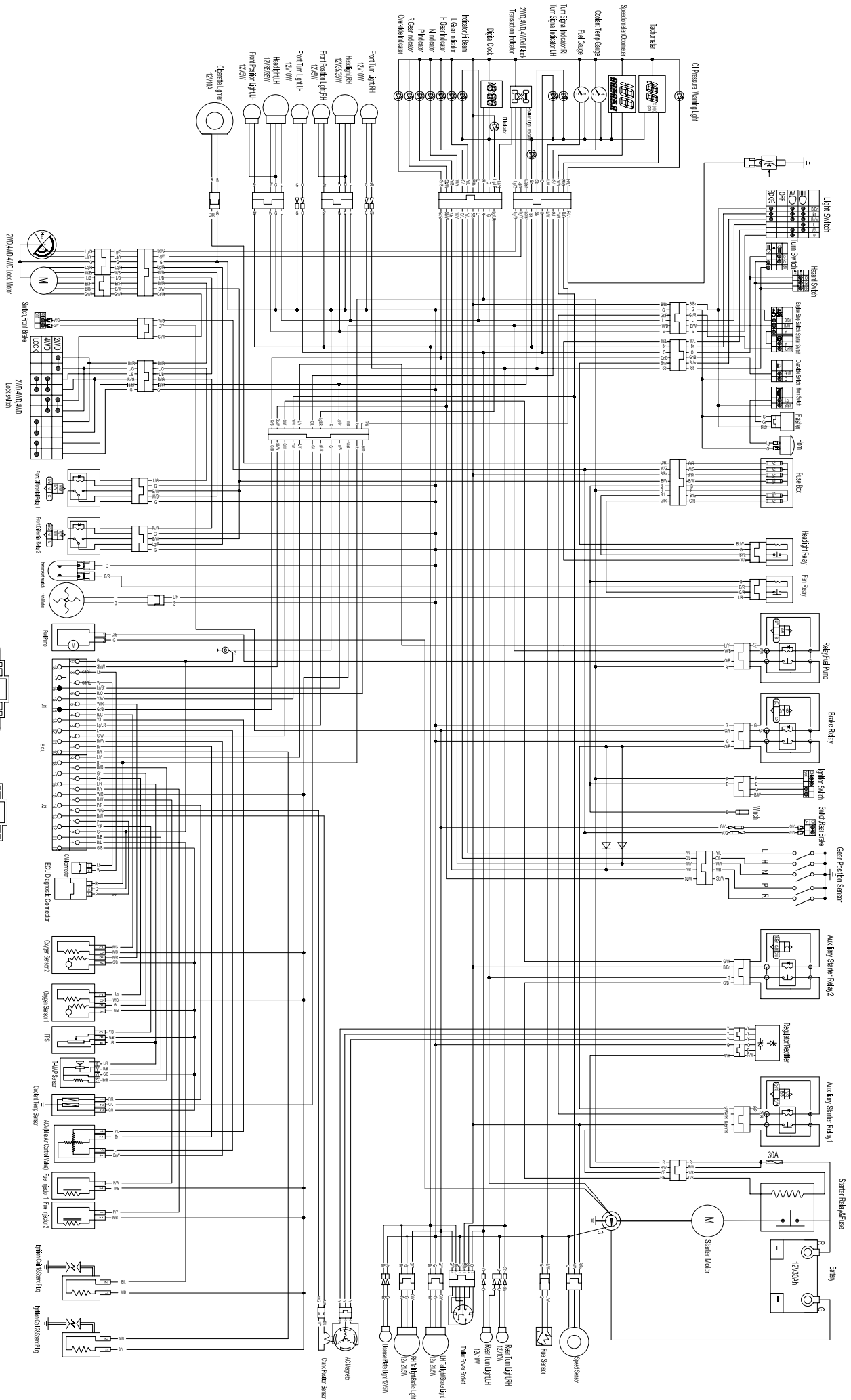

Perhatikan bahwa semua busbar dan kabel harus dipasang dengan benar. Pastikan semua koneksi terdapat pada busbar yang sesuai. Pastikan semua kabel terdapat pada busbar yang sesuai. Pastikan semua kabel terdapat pada busbar yang sesuai. Pastikan semua kabel terdapat pada busbar yang sesuai.



Maintenance Info.....	16-1	Handlebar Switches.....	16-7
Troubleshooting.....	16-2	Brake Light Switch-Horn.....	16-8
Bulb replacement.....	16-3	Fuel Sensor.....	16-9
Dashboard- Headlight.....	16-5	Fuel pump.....	16-10
Ignition Switch.....	16-6		

Maintenance Information

Operation Cautions

WARNING

- Headlight bulb will be very hot when it is turned on. Do not touch it after it is just turned off.
Operation should be done when the bulb is cooled down.
- The temperature of headlight is quite high when turned on. Replacing with bare hand or stained glove will leave oil residue on the glass face which may form hot spot and cause deformation of glass face and damage to bulb.
- Pay attention to the following when replacing the bulb.
Do not replace the bulb when it is turned on. Keep ignition switch in the OFF position, and replace after the bulb is cooled down.
- Replace the bulb with hands in clean gloves to avoid oil residue on the glass surface.
- Clean the glass with a clean rag dipped in alcohol or isoamyl acetate in case of any oil residue on the glass surface.
- If the inspection has to be done with battery, check if the battery is normal.
Inspection of switch continuity can be done without removing switches from the vehicle.
- After the inspecting and maintenance of each part, cables and wires should be routed properly (chapter 1). Refer to Chapter 2 for removal and installation of taillight and rear turning lights.

Maintenance Specifications

Item		Standard
Fuse	Main	20 A
	Auxiliary	10 A x 1 15 A x 5
Light	Headlight (Hi / Lo)	12 V-35/35 W x 2
	Brake light / Taillight	12 V-21/5W x 2
	Turn Light	12 V-10W x 4
	Panel Light	LED
	Coolant temp., Fuel level, 2WD/4WD indicator light	LCD
	MIL	LED

Troubleshooting

Head Light Cannot Turn On

- Blown fuse
- Open circuit of main cable
- Burnt bulb
- Defective switch

Bulb Replacement

Headlight Bulb

Cautions

Headlight bulb will be very hot when it is turned on.
Do not touch it after it is just turned off.
Operation should be done when the bulb is cooled down.

Remove left headlight protector (→2-11);

Remove headlight(→16-5);

Remove left position light(front) no.1;

Remove headlight bulb (left) no.2;

Remove left turn light no.3;

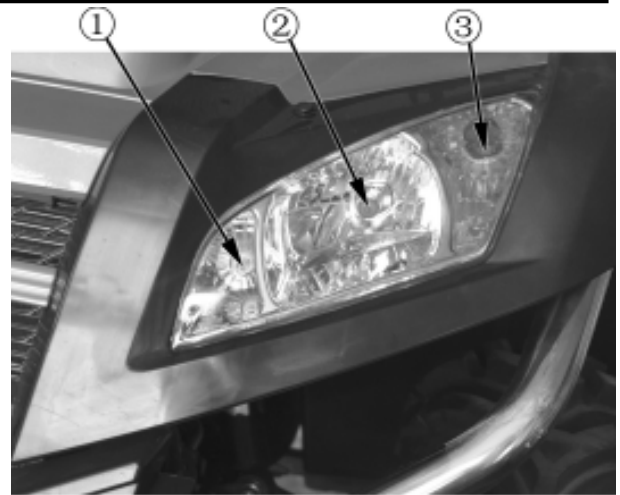

Unplug headlight connector;

Remove dust-proof cap, headlight connector, circlip and replace with a new bulb.

WARNING:

Wear clean gloves when replacing bulb.

Oil residue on the glass surface may cause the bulb break. Clean the stained surface with alcohol or isoamyl acetate.

Align the three pins of the bulb with the three positioning holes in the socket when replacing the bulb.

Bulb no.7 specification:12V-35/35W

Bulb no.6 specification:12V-5W

Bulb no.5 specification :12V-10W

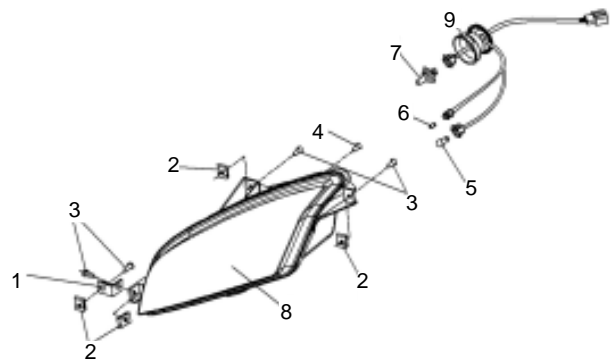

Reverse the removal procedure for installation
After replacing the bulb, adjust headlight beam (→ 3-14).

Headlight Inspection

Turn the ignition switch to ON position,
turn light switch to the illumination position and check if the headlight is on.

-ON: Normal

-Still off: short circuit of main cable or broken main cable

Front Turn Light Bulbs

Remove LH headlight protector(→2-11);
Remove headlight(→16-5);
Remove front turn light no.1;
Remove front turn light bulbs.

Bulb Specification:12V-10W

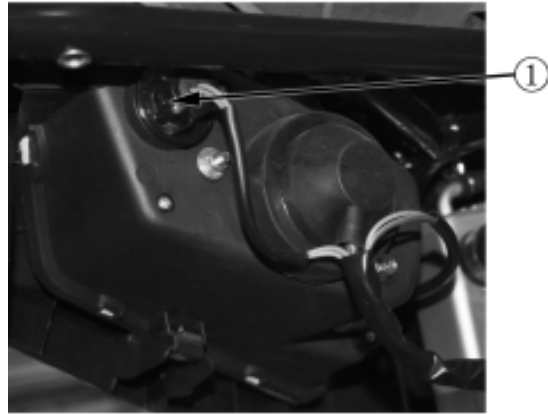

Rear Turn Light Bulbs

Remove rear turn light cover;
Remove rear turn light bulbs;
Replace rear turn light bulbs no.4;
Bulb Specification:12V-10W

Reverse the removal procedure for installation.

Brake Light/Tail Light Bulb

Remove tail light cover;
Remove brake light/tail light bulb no.5;

Replace brake light/tail light bulb;
Bulb Specification:12V-21/5W
Reverse the removal procedure for installation.

NOTE:

Main cable, wiring and tube should be routed properly(→Chapter 1).

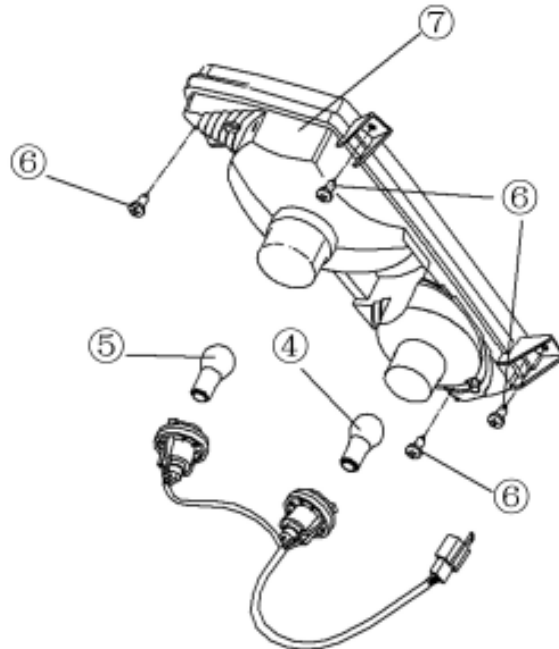

Dashboard

Remove cover of dashboard(→2-5);
Remove nuts no.1;
Remove dashboard connectors no.2;

Remove dashboard.

NOTE: *If dashboard has something wrong,
it's recommended to replace the whole dashboard.*

Reverse the removal procedure for installation.

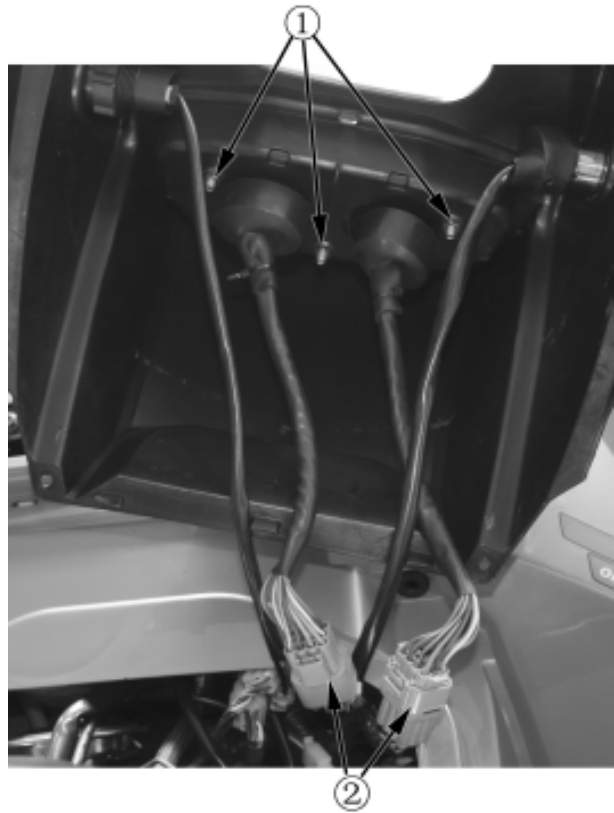

Headlight

Remove cover of headlight (-2-11);
Remove screw no.3;
Remove screw o.4;
Disconnect headlight connector;
Disassemble headlight comp.

Reverse the removal procedure for installation

NOTE:

*Be careful not to damage main cable when
assembling.*

After replacement, adjust the headlight beam(→3-14);

NOTE:

*Main cables and wires should be routed
properly.(→ 1-20)*

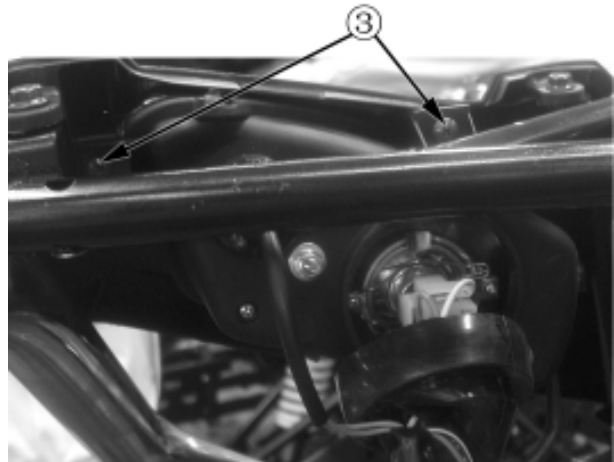

Ignition Switch

Inspection

Remove dashboard cover(→2-5);
Disconnect 4P connector of ignition switch;
Check according to the following table if the connector terminals are in continuity.

●—●:Continuity

ON	●—●			
OFF			●—●	●—●
P←			●—●	●—●
	R	B	G	B/W

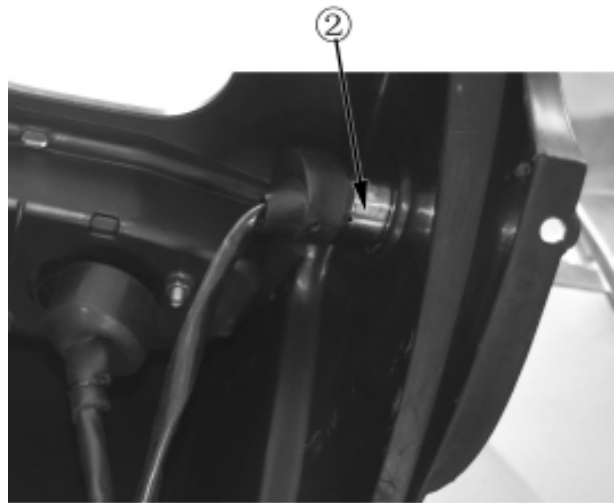
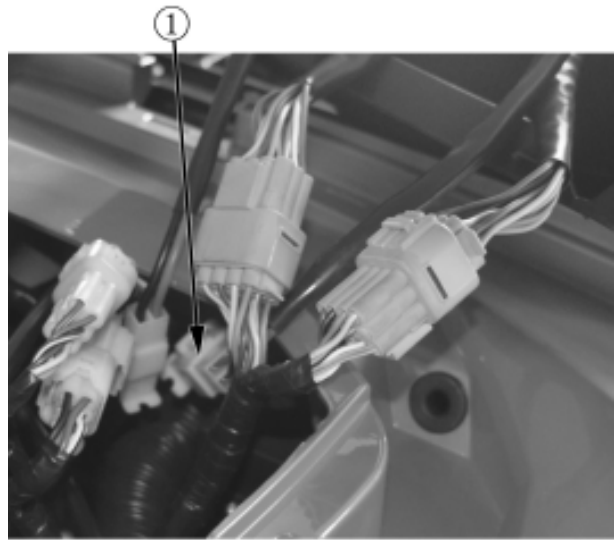

Removal

Remove dashboard cover(→2-5);
Disconnect 4P connector of ignition switch;

Remove bolt and remove ignition switch;

Installation

Reverse the removal procedure for installation.

Handlebar Switches

Remove dashboard cover(→2-5);
 Disconnect left handlebar switch connectors;
 Check according to the following table if
 the connector terminals are in continuity.

●—●Continuity

Light Switch no.1

↖	B/Br	Br	Br/W	L	W/L	W
☰	●—●	●—●	●—●	●—●	●—●	
☷	●—●	●—●	●—●		●—●	●—●
OFF						
☶	●—●	●—●	●—●			

B=Black Br=Brown W=White L=Blue G=Green
 Gr=Grey R=Red O=Orange Sb=Sky Blue
 Lg=Light Green

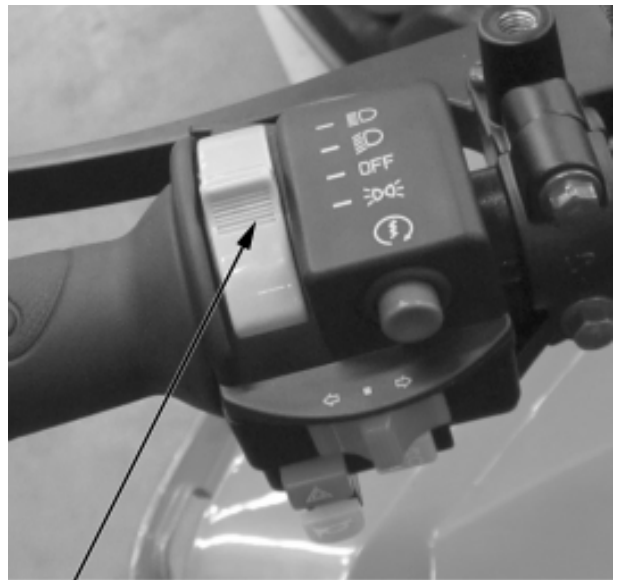

①

②

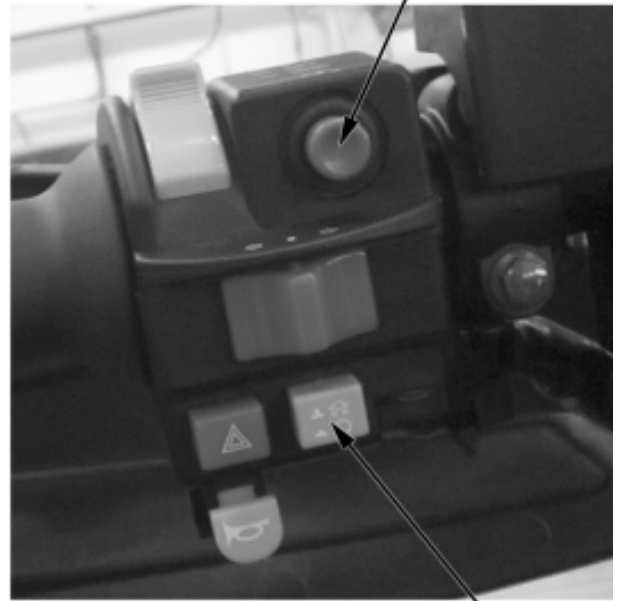

③

Kill Switch no.3

Starter Switch no.2

↖	B/W	G	B/Br	Y
☒	●—●			
☑			●—●	●—●

↖	Y	Gr/R
⚡	●—●	

Turn Switch no.1

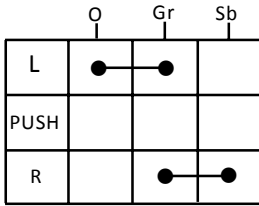

Horn switch no.3 Over-ride Switch no.4

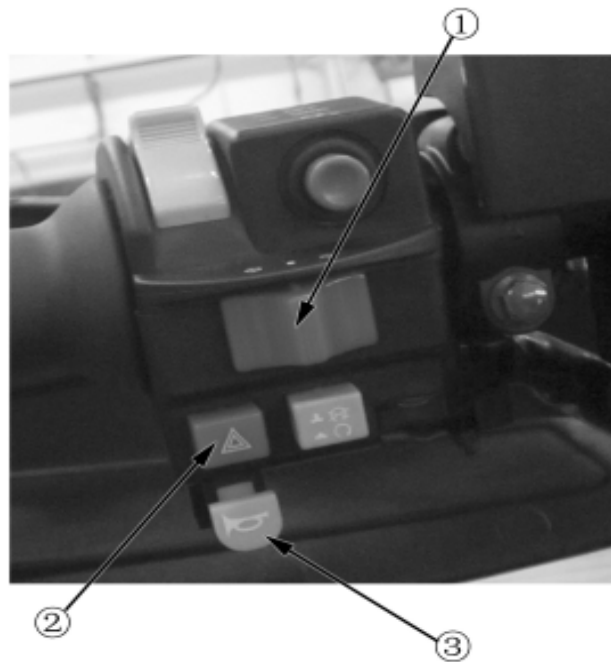
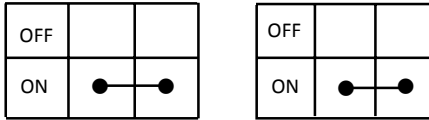

Right Handbar Switch no.5

	Br/B	L/G	L/B	Br/G	Gr/W	L/G	Br/R	Br/G	Lg/Br	G
2WD	●	●			●	●				
4WD			●	●	●	●				
LOCK			●	●			●	●	●	●



If something above wrong, replace handlebar switches(→12-12).

Hazard Light Switch no.2

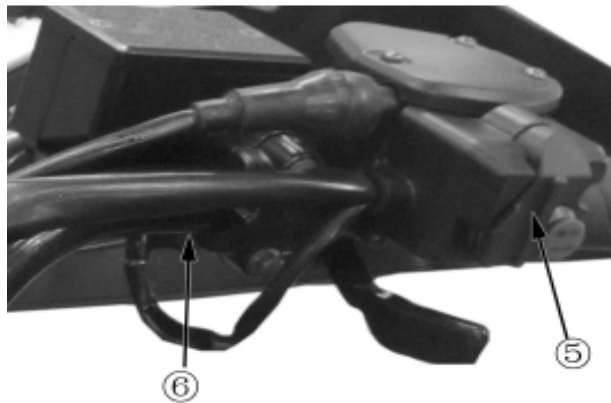
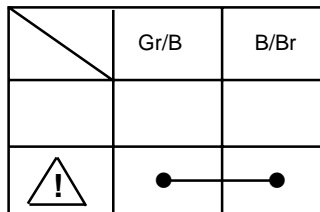

Brake Light Switch no.6

Disconnect brake light switch connector and check terminals for continuity.

Brake lever applied:continuity

Brake lever released. no continuity

No continuity: Replace brake light switch



Horn no.7

Inspection

Remove front vent grille (→2-13);

Disconnect horn;

Connect with a fully charged 12V battery and check if the horn sounds.

Defective Horn: Replace

Fuel Sensor

Remove:

Remove passenger seat (→2-4);

Remove driver seat (→2-4);

Remove fuel sensor;

Disconnect 2P connector.

Inspection

Remove fuel sensor (refer to above steps);

Connect 2P connector;

Turn ignition switch to ON;

Shake fuel sensor float with hand, locate the float position and check if it conforms to the fuel gauge reading.

Non-conformity: -check main cable for damage or short circuit

-Check fuel sensor and fuel gauge.

Remove fuel sensor 2P connector;

Connect multimeter between 2P connector terminals;

Shake float with hand and measure the resistance of float at different positions.

Connection Terminal:

Upper: Blue/White-Green:

4-10 Ω (20°C)

Lower: Blue /White-Green:

90-100 Ω (20°C)

Faulty fuel sensor: Replace

Installation

Put fuel sensor into installation hole of fuel tank.

Fuel sensor should be fitted properly.

No fuel leakage is allowed.

Inspection of Fuel Gauge

Switch on power supply and check if fuel level gauge functions normally.

If fuel gauge works normally,

Reverse the removal procedure for

installation of plastic parts and seat.

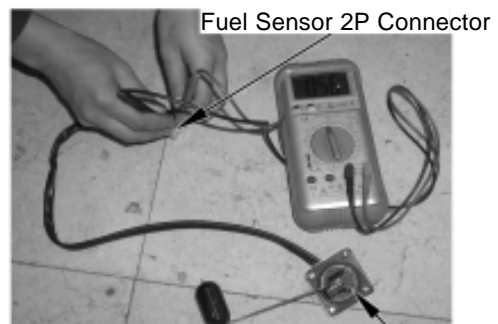
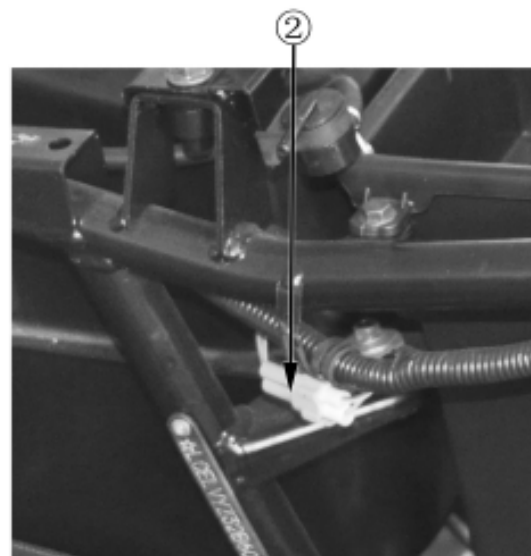
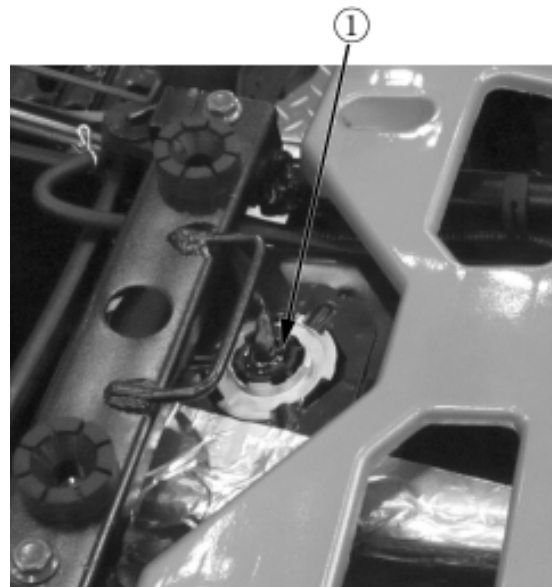

Fuel Pump

Removal

Remove rear seat(→2-4);

Remove front seat(→2-4);

Remove related plastics(see **Chapter 2**);

Drain fuel in fuel tank ;

Remove the 5 bolts no. 2;

Remove fuel pump no.3 from fuel tank no.1;

Disconnect fuel pump connector.

Fuel Pump Specifications

Voltage:DC13.5 ± 0.3V,

Pressure:0.2 ± 0.01MPa,

Rate of flow ≥ 45L/h,

Current ≤ 2A,

Regulator working pressure: 0.25 ± 0.01MPa,

Current ≤ 2.2A.

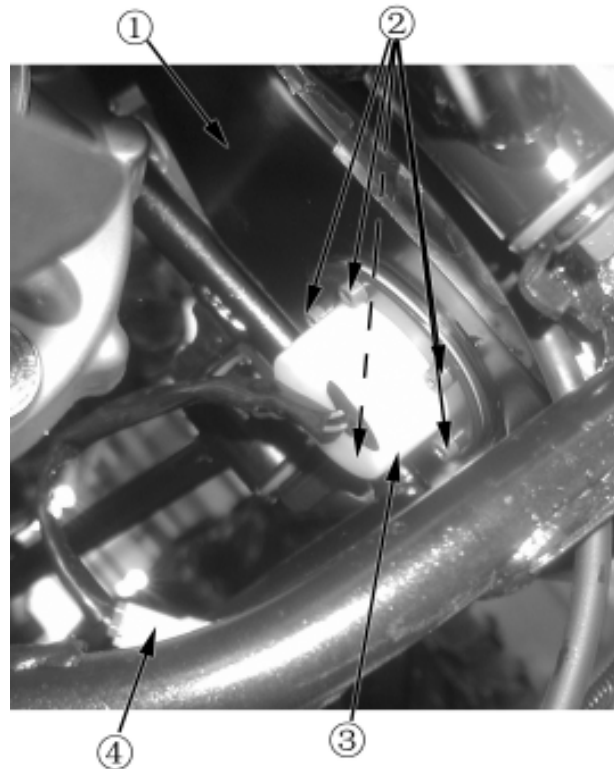

Inspection of Fuel Pump

Turn ignition switch to ON and check if fuel pump functions normally.

If fuel pump works abnormally, please check if circuit is open circuit or if EFI system has any problem.

NOTE:

If any problem of electrical equipment and electrical system in this chapter, please refer to chapter of electrical equipment.

1.Engine troubleshooting.....	17-2
2.Trouble code table.....	17-6
3.EFI system troubleshooting by trouble code.....	17-7
4.Trouble diagnosis by engine problems.....	17-13

1.Engine troubleshooting

Trouble	Possible causes	Countermeasures
Engine cannot be started	<ol style="list-style-type: none"> 1.Check electrical system <ol style="list-style-type: none"> 1) Fuse defective 2) Battery low voltage 3)Bad wiring connection 2.Check spark plug <ol style="list-style-type: none"> 1) Ignition coil bad connection or defective 2) High-tension cable bad connection or defective 3) Speed sensor defective 4) Flywheel defective 5) Gap of spark plug incorrect 6) Spark plug dirty 7) Spark plug wet 3. Check fuel supply system <ol style="list-style-type: none"> 1) Canister 2) Fuel pump leakage or defective 3) Fuel hose leakage 4) Fuel insufficient 5) Injector blocked or defective 4.Check cylinder pressure <ol style="list-style-type: none"> 1) Cylinder worn 2) Piston ring worn 3) Cylinder gasket broken 4) Valve stem worn 5) Valve seat seal unsuitable 6) Valve worn 7) Spark plug loose 8) Starting RPM too low 9) Valve timing incorrect 10) Valve clearance incorrect 5. Air bypass valve blocked or defective 6. Not shift to "N" gear 7. Check trouble code 	<ol style="list-style-type: none"> Check or replace Check or recharge Check or replace Check or replace Check or replace Check or replace Check or replace Adjust or replace Clean or replace Dry it or replace Repair or replace Tighten Check fuel tank Replace Replace Replace Replace Replace Repair or replace Replace Tighten Check or replace Adjust Adjust Clean or replace Shift to "N" gear Check
Difficult to start engine	<ol style="list-style-type: none"> 1. Air bypass valve adjustment failure 2. TPS not reset 3. Adjust throttle cable 4. Cylinder pressure insufficient 5. Check spark plug <ol style="list-style-type: none"> 1) Spark plug defective 2) Spark plug improper installation 3) Spark plug damaged 4) Spark plug dirty 6. Fuel insufficient or fuel pressure not enough 	<ol style="list-style-type: none"> See engine control system See engine control system Check or replace Replace defective part

17 TROUBLESHOOTING

Trouble	Possible causes	Countermeasures
Engine overheating	<ol style="list-style-type: none"> 1. Coolant insufficient (lower than LOWER line) 2. Air bubbles inside cooling system 3. Water temp. sensor defective 4. Thermostat defective(cannot open when coolant is very hot) 5. Coolant leakage <ul style="list-style-type: none"> ● Water hose broken or aging ● Clamp loosen 6. Water impeller damaged 7. Water pump cover leaking 8. Cylinder head cover/Cylinder gasket leakage 9. Water pump cover washer leakage 10. Water pump gear wear or damaged 11. Water pump shaft defective 	Refill coolant Remove air bubbles and refill Replace sensor Replace thermostat a. Check and replace water pump seal b. Check and replace water hose and clamp Replace Tighten Replace Tighten or replace Replace Replace

Troubles	Possible causes	Countermeasures
Engine oil consumption too high or oil pressure too low	<ol style="list-style-type: none"> 1. Check oil level and if any leakage of crankcase or oil seal <ul style="list-style-type: none"> ● Crankcase damaged ● Tightening bolt loosen ● Seal ring or O-ring/washer damaged or broken ● Piston ring wear (blue spark can be seen) ● Piston ring damaged (compression ratio too low) ● Oil seal of valve damaged or aging 2. Oil filter blocked 3. Check oil drain plug screw of crankcase <ul style="list-style-type: none"> ● Oil drain plug screw loosen ● Oil drain plug screw of left crankcase loosen or washer is missing 4. Oil seal of indicator hole is leaking 5. Oil strainer blocked 6. Check oil pump <ul style="list-style-type: none"> ● Oil pump rotor over-worn ● Oil pump leakage or damaged by air into oil pump ● Oil pump gear damaged ● Engine oil is unsuitable 	Replace and reassembly Replace Tighten Replace Replace Replace Replace all oil seal of valves Replace and change oil Tighten Tighten or install washer Replace oil seal Clean or replace Replace Replace Replace Use recommended oil
Engine oil whitening	<ol style="list-style-type: none"> 1. Coolant and oil leaking from leakage indicator hole 2. Cylinder head cover and cylinder gasket damaged 3. Bolt of cylinder head cover loosen 4. Engine oil impure 	Replace oil seal and water seal Tighten or replace Tighten and change oil Replace damaged parts (including oil filter and oil)

17 TROUBLESHOOTING

Abnormal acceleration	<ol style="list-style-type: none"> 1. CVT belt getting narrow 2. Check drive pulley <ul style="list-style-type: none"> ● Rollers wear ● Drive pulley track wear 3. Drive/driven pulley shaft move not flexibly 4. Spring of driven pulley too strong 5. Sliders of driven pulley wear 6. Groove of drive/driven pulley damaged 7. Intake&exhaust valve clearance incorrect 8. Compression ratio too low 9. Ignition of spark plug abnormal 	<p>Replace</p> <p>Replace</p> <p>Replace</p> <p>Clean or replace</p> <p>Replace</p> <p>Replace</p> <p>Replace</p> <p>Adjust</p> <p>Replace</p>
Max. speed too low	<ol style="list-style-type: none"> 1. Check point 1,2 and 3 of “abnormal acceleration” 2. CVT system polluted by water, oil and dust 3. Drive pulley blocked 4. Spring of driven pulley weak or damaged 	<p>Clean and replace</p> <p>Clean or replace</p> <p>Replace</p>
Transmission not good	<ol style="list-style-type: none"> 1. Check bush of drive pulley 2. Check point 1and 2 of “abnormal acceleration” <ul style="list-style-type: none"> ● Bush blocked on shaft 3. Check driven pulley <ul style="list-style-type: none"> ● Spring of driven pulley weak or damaged ● Sliders wear or damaged 	<p>Clean and Replace</p> <p>Replace</p> <p>Replace</p>
CVT belt over-worn or burned	<ol style="list-style-type: none"> 1. Check CVT inlet&outlet air pipe <ul style="list-style-type: none"> ● CVT overheating ● Drive fixing sheave impeller blocked 2. Check pulley groove <ul style="list-style-type: none"> ● Dirty oil inside groove ● Water into CVT case 	<p>Clean</p> <p>Clean</p> <p>Clean and replace belt</p> <p>Clean and replace belt</p>
CVT belt not good	<ol style="list-style-type: none"> 1. Belt over-worn and getting narrow 2. Wrong belt 3. Part of belt wear 4. Belt broken or over-used 5. Dirty oil inside groove 6. Drive/driven pulley groove damaged by stone or other foreign objects 7. Belt aging and getting fragile 	<p>Replace</p> <p>Replace</p> <p>Replace</p> <p>Clean CVT system and replace belt</p> <p>Clean</p> <p>Clean or replace</p> <p>Replace</p>

17 TROUBLESHOOTING

Noise from cylinder head	<ol style="list-style-type: none"> 1. Valve clearance incorrect 2. Tensioner failure 3. Chain guide wear 4. Chain extended or chain sprocket wear 5. Bolt of sprocket loosen 6. Valve rocker arm or camshaft wear 7. Camshaft timing incorrect 	<p>Adjust or replace</p> <p>Replace</p> <p>Replace</p> <p>Replace</p> <p>Tighten</p> <p>Adjust or replace</p> <p>Adjust or replace</p>
Noise from crankshaft and connecting rod	<ol style="list-style-type: none"> 1. Bearing damaged 2. Plain bearing damaged 3. Flywheel rotor loosen 4. Bearing of left crankcase cover wear 	<p>Replace</p> <p>Replace</p> <p>Tighten or replace</p> <p>Replace</p>
Noise from crankcase	<ol style="list-style-type: none"> 1. Engine oil leaking 2. Gear damaged or wear 	<p>Replace, tighten and add oil</p> <p>Replace</p>
Noise from CVT when at idle speed	<ol style="list-style-type: none"> 1. Bush of driven pulley blocked or wear 2. Check drive pulley 3. Rollers wear 4. Drive pulley track wear 5. Drive moving sheave wear 6. Nylon sliders wear 7. Axial move blocked 8. Nut of drive pulley loosen 	<p>Replace driven pulley</p> <p>Replace at the same times</p> <p>Replace</p> <p>Replace</p> <p>Replace</p> <p>Clean or replace</p> <p>Tighten</p>
Noise from CVT when at transmission	<ol style="list-style-type: none"> 1. Check point 1~3 of idle abnormal noise 2. Drive pulley dirty and wet 3. Nut of drive/driven loosen 4. Driven sliders over-worn 5. Belt and cone surface damaged by outside materials 	<p>Clean and dry</p> <p>Tighten</p> <p>Replace</p> <p>Clean or replace</p>
CVT drive pulley vibration	<ol style="list-style-type: none"> 1. Nut of drive pulley loosen 2. Gap of bush of drive pulley too big 3. Rollers missing or over-worn 	<p>Tighten</p> <p>Replace</p> <p>Replace at the same times</p>
CVT driven pulley vibration	Gap of bush of driven pulley too big	Replace

2. Trouble code table

Trouble Code	Trouble Description	Remarks
P0107	MAP Circuit Low Voltage or Open	MAP-Manifold Absolute Pressure
P0108	MAP Circuit High Voltage	
P0112	IAT Circuit Low Voltage	IAT-Inlet Air Temperature
P0113	IAT Circuit High Voltage or Open	
P0117	Coolant/Oil Temperature Sensor Circuit Low Voltage	
P0118	Coolant/Oil Temperature Sensor Circuit High Voltage or Open	
P0122	TPS Circuit Low Voltage or Open	TPS-Throttle Body Position
P0123	TPS Circuit High Voltage	
P0131	O2S 1 Circuit Low Voltage	O2S-Oxygen Sensor
P0132	O2S 1 Circuit High Voltage	
P0032	O2S 1 Heater Circuit High Voltage	
P0031	O2S 1 Heater Circuit Low Voltage	
P0201	Injector 1 Circuit Malfunction	
P0202	Injector 2 Circuit Malfunction	
P0230	FPR Coil Circuit Low Voltage or Open	FPR-Fuel Pump Relay
P0231	FPR Coil Circuit Low Voltage or Open	
P0232	FPR Coil Circuit High Voltage	
P0336	CKP Sensor Noisy Signal	CKP-Crankshaft Position
P0337	CKP Sensor No Signal	
P0351	Cylinder 1 Ignition Coil Malfunction	
P0352	Cylinder 2 Ignition Coil Malfunction	
P0505	Idle Speed Control Error	
P0562	System Voltage Low	
P0563	System Voltage High	
P0650	MIL Circuit Malfunction	MIL-Malfunction Indicator Light
P1693	Tachometer Circuit Low Voltage	
P1694	Tachometer Circuit High Voltage	
P0137	O2S 2 Circuit Low Voltage	
P0138	O2S 2 Circuit High Voltage	
P0038	O2S Heater 2 Circuit High Voltage	
P0037	O2S Heater 2 Circuit Low Voltage	
P0500	VSS No Signal	VSS-Vehicle Speed Sensor

3. EFI troubleshooting by trouble code

Instructions:

1. Only after stable trouble is confirmed, then do checking and repair. Otherwise it will bring mistakes.
2. Below mentioned multimeter is only for digital multimeter, pointer multimeter is not allowed for checking EFI circuit.
3. If trouble code means voltage too low, it is short circuit to ground or open circuit. If trouble code means voltage too high, it is short circuit to power. If trouble code means circuit has something wrong, then there is open circuit or many circuits in trouble.

Diagnosis helps:

1. If trouble code cannot be removed, then it is stable trouble.
If it is temporary trouble, please check wiring connectors
2. During checking, do not neglect influences of vehicle maintenance, cylinder pressure and valve timing.
3. Replace ECU and test.
If trouble code can be removed by replacement of ECU, then it is a trouble originated from ECU. If trouble code still exists, then install original ECU and check other parts step by step.

In the following, there are detailed descriptions about trouble codes and diagnosis procedures.

Trouble code:P0032/P0038: Heater coil high voltage of Cylinder 1 and 2 oxygen sensor

Possible causes	Checking procedures
1) Open circuit between ECU and oxygen sensor C pin 2) Open circuit between main relay and oxygen sensor C pin. 3) Open circuit between oxygen sensor C and D pin	1) Measure resistance between ECU pins and oxygen sensor C pin, check if it's ok. 2) Measure resistance between main relay and oxygen sensor D pin, check if it's ok. 3) Measure resistance (9.6KΩ) between oxygen sensor C pin and D pin.

Trouble code P0031/P0037: Heater coil low voltage of Cylinder 1 and 2 oxygen sensor

Possible causes	Checking procedures
1) Short circuit between ECU and ground. 2) Short circuit between ECU and oxygen sensor D pin 3) Short circuit between ECU and other circuits.	1) Measure resistance between ECU and ground 2) Measure ECU voltage and check if it's ok. 3) Measure resistance (9.6KΩ) between oxygen sensor D pin and ECU

Trouble code :P0131/P0137: Oxygen sensor low voltage of cylinder 1 and 2

Tips: EFI system can judge output signal if it's ok by measuring voltage between oxygen sensor A pin and B pin.

Oxygen sensor sometimes will be broken during cold starting.

Possible causes	Checking procedures
1) Short circuit between ECU and ground 2) Short circuit between ECU and oxygen sensor D pin. 3) Short circuit between ECU and other circuits. 4) Oxygen sensor defective, replace it.	1) Measure resistance between ECU and ground and check if it's ok. 2) Measure ECU voltage and check if it's ok. 3) Measure resistance (9.6KΩ) between oxygen sensor D pin and ECU

Trouble code : P0132/P0138: Oxygen sensor high voltage of cylinder 1 and 2

Possible causes:	Checking procedures
1) Open circuit between ECU and oxygen sensor A and B pins. 2) Open circuit between oxygen sensor A pin and B pin	1) Replace oxygen sensor 2) Replace ECU 3) Wiring checking.

Trouble code P0107: Intake air temp. sensor low voltage or open circuit

Possible causes: 1) The sensor short circuit to ground	Repair procedures: 1) Measure resistance between ECU and ground
---	--

Trouble code P0108: Intake air temp. sensor high voltage

Possible causes: 1) The sensor short circuit to ground	Repair procedures: 1) Measure ECU pin voltage
---	--

Trouble code P0112: Intake air temp. sensor low voltage

Possible causes: 1) The sensor connected with ECU pin short circuit to ground	Repair procedures: 1) Measure resistance between ECU pin and ground
--	--

Trouble code P0113: Intake air temp. sensor high voltage or open circuit

Possible causes: 1) The sensor connected with ECU pin short circuit to power	Repair procedures: 1) Measure sensor voltage connected with ECU pin if it's ok.
---	--

Trouble code P0117: Water temp. sensor low voltage

Possible causes: 1)The sensor connected with ECU pin short circuit to ground	Repair procedures: 1) Measure resistance between ECU pin and ground.
---	---

Trouble code P0118: Water temp. sensor high voltage or open circuit

Possible causes: 1) The sensor connected with ECU pin short circuit to other circuit.	Repair procedures: 1) Measure voltage of ECU pin if it's ok.
--	---

Trouble code P0122: TPS low voltage or open circuit

Possible causes: 1) ECU pin short circuit to ground	Repair procedures: 1) Measure resistance between ECU pin and ground
--	--

Trouble code P0123: TPS high voltage

Possible causes: 1) Short circuit between ECU pin and other circuit	Repair procedures: 1) Measure voltage connected with ECU pin if it's ok.
--	---

Trouble code P0201/ P0202: 1/2 cylinder injector coil defective

Possible causes: 1) Injector coil if it's open circuit. 2) Improper connection between injector pin and ECU pin 3) Improper connection between injector pin and relay 4) All drive circuit connected with ECU short to ground 5) Short circuit between ECU pin and other circuit.	Repair procedures: 1) Measure injector resistance 2) Check continuity of all wirings 3) Measure resistance between ECU pin and ground 4) Measure voltage connected with ECU pin.
--	--

Trouble code P0336: Pick-up (Crankshaft phase sensor) signal incorrect

Possible causes: 1) Wiring continuity short circuit or open circuit from time to time 2) Installation of crankshaft signal wheel improperly 3) RPM sensor installation improperly	Repair procedures: 1) Check wiring continuity if it's ok. 2) Check flywheel rotor gear quantity.
--	--

Trouble code P0337: Pick-up (crankshaft phase sensor) no signal

After engine is started, ECU will monitor pick-up signal and other signals at the same time.

It will judge if pick-up signal is missing or not by signal reasonability.

Possible causes: 1) Open circuit between RPM sensor and ECU 2) Short circuit between pick-up and ECU 3) Open circuit of pick-up coil.	Repair procedures: 1) Measure resistance between pick-up and ECU 2) Measure resistance of pick-up 3) Measure peak voltage of pick-up.
--	--

Trouble code P0230: Fuel pump relay coil low voltage or open circuit

Trouble code P0232: Fuel pump relay coil high voltage

<p>Possible causes:</p> <ol style="list-style-type: none"> 1) Open circuit/short to ground/short to power between control circuit of fuel pump relay connected with ECU and fuel pump relay 2) Open circuit between fuel pump relay and main relay. 3) Open circuit between relay coils. 	<p>Repair procedures:</p> <ol style="list-style-type: none"> 1) Measure resistance or voltage between ECU and fuel pump relay. 2) Measure resistance between fuel pump relay and main relay. 3) Measure resistance between two pins of fuel pump relay.
---	--

Trouble code P0505: Out of idle speed when at idle condition

Engine idle speed is controlled by ECU close-loop. In case ECU gives idle instruction, but engine idle speed still is higher than targeted idle speed set by ECU, then it's trouble.

<p>Possible causes:</p> <ol style="list-style-type: none"> 1) Check adjust screw of throttle, throttle cable and throttle working condition if it's ok. 2) Too dirty inside throttle body. 	<p>Repair procedures:</p> <ol style="list-style-type: none"> 1) Switch off ignition more than 3 seconds and restart engine.
--	--

Trouble code P0562: Battery low voltage

Trouble code P0563: Battery high voltage

<p>Possible causes:</p> <ol style="list-style-type: none"> 1) Flywheel already broken and cannot generate power or battery power leakage 2) Open circuit of flywheel stator coil. 3) Regulator already damaged 	<p>Repair procedures:</p> <ol style="list-style-type: none"> 1) Check flywheel power generation (By measuring flywheel voltage) 2) Measure regulator voltage
---	---

Trouble code P0650: MIL light drive circuit defective

<p>Possible causes:</p> <ol style="list-style-type: none"> 1) Open circuit/short to ground/short to power between ECU and MIL light drive circuit. 2) Open circuit between MIL and main relay 3) MIL light burnt 	<p>Repair procedures:</p> <ol style="list-style-type: none"> 1) Measure resistance or voltage between ECU and MIL light drive circuit.
---	---

Trouble code P0500: Speed sensor no signal

When vehicle is running with gear and with loose throttle body, ECU will monitor engine RPM and speed sensor. In case engine has high RPM, but speedometer shows 0 or very low, then it's a trouble of speed sensor.

<p>Possible causes:</p> <ol style="list-style-type: none"> 1) Short or open circuit between ECU and speed sensor 	<p>Repair procedures:</p> <ol style="list-style-type: none"> 1) Measure resistance between ECU pins and speed sensor. 2) Measure resistance between ECU pins and ground
---	---

Trouble code: P0850 Neutral gear sensor defective

Engine cannot be started when at "N" gear position.

Possible causes: 1) Open circuit between N gear sensor and ground	Repair procedures: 1) Measure resistance between ECU pin and N gear sensor
--	---

Trouble code: P0445 Starter auxiliary relay high voltage

Trouble code: P0444 Starter auxiliary relay low voltage or open circuit

Possible causes: 1) Open circuit/short to ground/short to power between ECU and auxiliary relay. 2) Open circuit between auxiliary relay and power. 3) Open circuit between relay coils.	Repair procedures: 1) Measure resistance or voltage between ECU and auxiliary relay. 2) Measure resistance between auxiliary relay and power. 3) Measure resistance between auxiliary relay two pins.
---	--

Trouble code P1693: RPM low output voltage

Trouble code P1694: RPM high output voltage

After engine is started, ECU will monitor pick-up signal and other signals.

It will judge if pick-up signal is missing or not by signal reasonability.

Possible causes: 1) Short circuit or open circuit between wirings from time to time. 2) Improper installation of crankshaft signal wheel. 3) Improper installation of RPM sensor 4) Open circuit between RPM sensor and ECU 5) Short circuit between pick-up and ECU 6) Open circuit between pick-up coils	Repair procedures: 1) Check wiring continuity. 2) Check flywheel rotor gear quantity. 3) Measure resistance between pick-up and ECU 4) Measure resistance of pick-up 5) Measure peak voltage of pick-up.
--	---

Trouble code P0351/ P0352: 1/2 ignition coil defective

Possible causes: 1) Ignition coil open circuit 2) Improper connection between ignition coil and ECU pins. 3) Improper connection between ignition coil and relay. 4) Short circuit between drive circuit connected with ECU and ground. 5) Short circuit between ECU pin and other circuits	Repair procedures: 1) Measure resistance of ignition coil 2) Check wiring continuity. 3) Measure resistance between ECU pin and ground 4) Measure voltage between ECU pins
--	--

4. Trouble diagnosis by engine problems

Before trouble diagnosis by engine problems, initial checking should be done as follows.

1. Confirm if trouble light is ok;
2. Confirm there's no trouble code record by PDA checking.
3. Confirm there's really trouble existing complained by end-users.

Then check the following points.

- (1) Check fuel hoses if any fuel leakage;
- (2) Check vacuum pipes if any broken, twist or improper connection;
- (3) Check intake manifold if any blocked, air leakage or damaged;
- (4) Check high-tension cable if any damaged, aging; or ignition order is correct.
- (5) Check wiring close to ground if it's clean and firm;
- (6) Check connector of all sensors and actuator if any loose or improper connection.

Important note: In case there're some problems as above-mentioned, then removal work should be done firstly, then go to next diagnosis.

Diagnosis helps:

1. Confirm engine without any trouble record.;
2. Confirm there's really trouble existing;
3. During checking, do not neglect vehicle periodic maintenance, cylinder pressure, valve timing, fuel supply and so on;
4. Replace ECU to test.

In case trouble disappears, then it's a problem of ECU. If trouble still exists, then assemble original ECU and check other points.

Frequent troubles list:

- When starting engine, engine cannot rotate or rotate slowly.
- When starting engine, starter motor can rotate but cannot start engine.
- Difficult to start warm or hot engine
- Difficult to start cold engine
- RPM is ok, but difficult to start engine.
- Starting is ok, but idle speed is unstable at any time.
- Starting is ok, but idle speed is unstable during engine warm-up period.
- Starting is ok, but idle speed is unstable after engine warm-up.
- Starting is ok, idle speed is unstable or engine stop when switch on some lights or other electric components.
- Starting is ok, but too high idle speed.
- RPM cannot go up or engine stop when acceleration.
- Slow acceleration.
- Insufficient power and bad performance when acceleration.

17 TROUBLESHOOTING

(1) When starting, engine cannot rotate or rotate slowly.

Possible causes: 1. battery; 2. starter motor; 3. wiring or ignition switch; 4. engine mechanical part.

General operation procedures:

Item No.	operation procedures	Result	Then
1	Use multimeter to measure voltage between positive and negative terminals of battery, normal value should be 8-12V when starting engine.	Yes	Next step
		No	Replace battery
2	Keep ignition switch on starting position, then use multimeter to measure voltage of positive terminal of starter motor. Normal value should be more than 8V.	Yes	Next step
		No	Repair or replace wiring
3	Remove starter motor and check if any open circuit or blocked by bad lubrication	Yes	Repair or replace starter motor
		No	Next step
4	If trouble only exists in winter, then resistance of starter motor is too big by unsuitable engine oil.	Yes	Change good engine oil
		No	Next step
5	Check if mechanical resistance is too big inside engine	Yes	Check resistance inside engine
		No	Repeat above procedures

(2) When starting, starter motor can rotate but engine cannot be started.

Possible causes: 1. No fuel inside fuel tank; 2. Fuel pump; 3. Pick-up; 4. Ignition coil;

5. Engine mechanical part.

General operation procedures:

Item No.	Operation procedures	Result	Then
1	Switch on ignition switch(repeat several times if necessary) or start engine and use fuel pressure meter to measure fuel pressure of fuel pump. Correct value should be around 330Kpa (3.30Bar)	Yes	Next step
		No	Check fuel supply system
2	Use PDA to see RPM data, and start engine to check if any RPM signal output.	Yes	Next step
		No	Check RPM sensor wiring
3	Disconnect high-tension cable and connect spark plug, keep spark plug 5mm away from engine body, then start engine to check if any white/blue spark occurs.	Yes	Next step
		No	Check ignition system

17 TROUBLESHOOTING

4	Check cylinder pressure if it's enough or not	Yes	Remove engine mechanical trouble
		No	Next step
5	Connect PDA and switch on ignition to check ECU-J2-15 pin and J2-18 pin if it is powered normally; Check ECU-J1-9 pin and J2-2 pin if it is connected to ground normally.	Yes	Use PDA to diagnose
		No	Check and repair wiring circuit

(3) Difficult to start hot or warm-up engine

Possible causes: 1. Fuel with water; 2. Fuel pump; 3. Water temp. sensor; 4. Ignition coil.

General operation procedures:

Item No.	Operation procedures	Result	Then
1	Connect fuel pressure meter and start engine to measure fuel pressure if it's around 330Kpa (3.30Bar)	Yes	Next step
		No	Check and repair fuel supply system
2	Disconnect high-tension cable and connect spark plug, keep spark plug 5mm away from engine body, then start engine to see if there's blue and white spark.	Yes	Next step
		No	Check and repair ignition system
3	Disconnect connector of water temp. sensor and start engine, check if engine can be started successfully. (or use a 300Ω resistant to connect water temp. sensor connector and check if engine can be started successfully.	Yes	Check and repair wiring or replace sensor
		No	Next step
		No	Next step
4	Check fuel quality and if it's caused only after filling fuel.	Yes	Change fuel
		No	Next step
5	Connect PDA and switch on ignition to check ECU-J2-15 pin and J2-18 pin if it is powered normally; Check ECU-J1-9 pin and J2-2 pin if it is connected to ground normally.	Yes	Use PDA to diagnose
		No	Check & repair wiring

(4) Difficult to start cold engine

Possible causes: 1. Fuel with water; 2. Fuel pump; 3. Water temp. sensor; 4. Injector; 5. Ignition coil; 6. Throttle body and air by-pass valve; 7. Engine mechanical part

General operation procedures:

17 TROUBLESHOOTING

Item no.	Operation procedures	Result	Then
1	Use fuel pressure meter and start engine to measure if fuel pressure is around 330Kpa (3.30Bar)	Yes	Next step
		No	Check and repair fuel supply system
2	Disconnect high-tension cable and connect spark plug, keep it 5mm away from engine body, then start engine to check if there's blue and white spark.	Yes	Next step
		No	Check and repair ignition system
3	Disconnect connector of water temp. sensor, start engine and check if it can be started successfully. (or use 2500Ω resistant to connect sensor and check if engine can be started successfully.	Yes	Check and repair wiring or sensor
		No	Next step
4	Open throttle very slowly to check if it can be started easily.	Yes	Clean throttle body and air by-pass valve
		No	Next step
5	Remove injector and use special cleaning equipment to check if any leakage or blocked	Yes	Replace injector
		No	Next step
6	Check fuel quality and if it is caused just after filling fuel	Yes	Change fuel
		No	Next step
7	Check cylinder pressure if it is enough or not.	Yes	Remove engine mechanical problem
		No	Next step
8	Connect PDA and switch on ignition to check ECU-J2-15 pin and J2-18 pin if it is powered normally; Check ECU-J1-9 pin and J2-2 pin if it is connected to ground normally.	Yes	Use PDA to diagnose
		No	Check and repair wiring

(5) RPM is ok, but difficult to start engine at any time.

Possible causes: 1. Fuel with water; 2. Fuel pump; 3. Water temp. sensor; 4. Injector; 5. Ignition coil; 6. Throttle body and air by-pass valve; 7. Intake manifold; 8. Ignition timing; 9. Spark plug; 10. Engine mechanical part

General operation procedures:

Item No.	Operation procedures	Result	Then
1	Check air filter if any blocked, or intake manifold if any blocked or leakage	Yes	Check and repair intake manifold
		No	Next step

17 TROUBLESHOOTING

2	Use fuel pressure meter and start engine to check if fuel pressure is around 330Kpa (3.30Bar)	Yes	Next step
		No	Check and repair fuel supply system
3	Disconnect spark plug cap and connect spark plug, keep it 5mm away from engine body, then start engine to check if there' s blue and white spark.	Yes	Next step
		No	Check and repair ignition system
4	Check spark plug if it is under technical specifications.	Yes	Next step
		No	Adjust or replace
5	Disconnect water temp. sensor connector and start engine to check if it can be started successfully.	Yes	Check and repair wiring or replace sensor
		No	Next step
6	Open throttle very slowly to check if engine can be started easily.	Yes	Clean throttle body
		No	Next step
7	Remove injector and use special cleaning equipment to check if any leakage or blocked.	Yes	Replace injector
		No	Next step
8	Check fuel quality and if it is caused just after filling fuel.	Yes	Change fuel
		No	Next step
9	Check cylinder pressure if it is enough.	Yes	Remove engine mechanical part
		No	Next step
10	Check ignition timing if it is ok.	Yes	Next step
		No	Check and repair ignition timing
11	Connect PDA and switch on ignition to check ECU-J2-15 pin and J2-18 pin if it is powered normally; Check ECU-J1-9 pin and J2-2 pin if it is connected to ground normally.	Yes	Use PDA to diagnose
		No	Check and repair wiring

(6) Starting is ok, but idle speed is unstable at any time

Possible causes: 1. Fuel with water; 2. Injector; 3. Spark plug; 4.Throttle body; 5.Intake manifold; 6. Air by-pass valve; 7.Ignition timing; 8.Spark plug; 9. Engine mechanical part

General operation procedures:

Item No	Operation procedures	Result	Then
1	Check air filter if any blocked, or intake manifold if any air leakage.	Yes	Check and repair intake manifold system
		No	Next step

17 TROUBLESHOOTING

2	Check if air by-pass valve is blocked	Yes	Clean or replace
		No	Next step
3	Check spark plug if it's under technical specifications.	Yes	Next step
		No	Adjust or replace
4	Check throttle body and by-pass air pipe if any carbon deposit.	Yes	Clean
		No	Next step
5	Remove injector and use special cleaning equipment to check if any leakage, blocked or incorrect fuel flow and so on.	Yes	Replace
		No	Next step
6	Check fuel quality and judge it's caused just after filling fuel.	Yes	Change fuel
		No	Next step
7	Check cylinder pressure if it's not enough.	Yes	Remove mechanical problem
		No	Next step
8	Check mechanical ignition timing if it's under technical specifications.	Yes	Next step
		No	Check and repair ignition timing
9	Connect PDA and switch on ignition to check ECU-J2-15 pin and J2-18 pin if it is powered normally; Check ECU-J1-9 pin and J1-2 pin if it is connected to ground normally.	Yes	Use PDA to diagnose
		No	Check and repair wiring

(7) Starting is ok, but idle speed is unstable during engine warming-up.

Possible causes: 1. Fuel with water; 2. Water temp. sensor; 3. Spark plug; 4. Throttle body and by-pass air pipe; 5. Intake manifold; 6. Air by-pass valve; 7. Engine mechanical part

General operation procedures:

Item No.	Operation procedures	Result	Then
1	Check air filter if any blocked or intake manifold any leakage	Yes	Check air filter and intake manifold
		No	Next step
2	Check spark plug if it's under technical specifications.	Yes	Next step
		No	Adjust or replace
3	Remove air by-pass valve and check throttle body, air by-pass valve and idle by-pass pipe if any carbon deposit.	Yes	Clean it
		No	Next step
4	Remove water temp. sensor and start engine to check if engine can keep stable idle during warming-up.	Yes	Check wiring or replace sensor
		No	Next step
5	Remove injector and use special cleaning equipment to check if any leakage, blocked or incorrect fuel flow and so on.	Yes	Replace
		No	Next step

19 TROUBLESHOOTING

6	Check fuel quality and if it's caused just after filling fuel.	Yes	Change fuel
		No	Next step
7	Check cylinder pressure if it's out of range.	Yes	Remove engine mechanical problem
		No	Next step
8	Connect PDA and switch on ignition to check ECU-J2-15 pin and J2-18 pin if it is powered normally; Check ECU-J1-9 pin and J2-2 pin if it is connected to ground normally.	Yes	Use PDA to diagnose
		No	Check and repair wiring

(8) Starting is ok, but idle speed is unstable after engine warming up.

Possible causes: 1. Fuel with water; 2. Water temp. sensor; 3. Spark plug; 4. Throttle body and idle by-pass pipe; 5. Intake manifold; 6. Air by-pass valve; 7. Engine mechanical part

General operation procedures:

Item No.	Operation procedures	Re-sult	Then
1	Check air filter if any blocked, and intake manifold if any leakage.	Yes	Check&repair air filter &intake manifold
		No	Next step
2	Check spark plug if it's under technical specifications.	Yes	Next step
		No	Adjust or replace
3	Remove air by-pass valve, check throttle body, air by-pass valve and it pipe if any carbon deposit.	Yes	Clean it
		No	Next step
4	Disconnect connector of water temp. sensor and start engine to see if any unstable idle during warming up	Yes	Check & repair wiring or replace sensor
		No	Next step
5	Remove injector and use special cleaning equipment to check if any leakage, blocked or incorrect fuel flow and so on.	Yes	Replace it
		No	Next step
6	Check fuel quality if it's caused just after filling fuel.	Yes	Change fuel
		No	Next step
7	Check cylinder pressure if it's out of range.	Yes	Remove mechanical problem
		No	Next step
8	Connect PDA and switch on ignition to check ECU-J2-15 pin and J2-18 pin if it is powered normally; Check ECU-J1-9 pin and J2-2 pin if it is connected to ground normally.	Yes	Use PDA to diagnose
		No	Check & repair wiring
9	Turn off ignition, and switch on ignition to restart engine after 3 seconds.	Yes	
		No	Check & repair wiring

(9) Starting is ok, but idle speed is unstable or killed off when lights (or other electrical components) switched on.

17 TROUBLESHOOTING

Possible causes: 1. Air by-pass valve; 2. Injector

General operation procedures:

Item No.	Operation procedures	Results	Then
1	Remove air by-pass valve, check throttle body, air by-pass valve and its pipe if any carbon deposit.	Yes	Clean it
		No	Next step
2	Check engine output power if it is too big when switching on electric components. And use PDA to check advanced ignition angle, fuel spray width and air intake flow.	Yes	Operate step 4
		No	Next step
3	Remove injector and use special cleaning equipment to check if any leakage, blocked or incorrect fuel flow and so on.	Yes	Replace it
		No	Next step
4	Connect PDA and switch on ignition to check ECU-J2-15 pin and J2-18 pin if it is powered normally; Check ECU-J1-9 pin and J2-2 pin if it is connected to ground normally.	Yes	Use PDA to diagnose
		No	Check&repair wiring

(10) Starting is ok, but idle speed is too high.

Possible causes: 1. Throttle body and idle pipe; 2. Injector seat; 3. Air by-pass valve; 4. Water temp. sensor; 5. Ignition timing

General operation procedures:

Item No.	Operation procedures	Result	Then
1	Check throttle cable if it is blocked or too tight.	Yes	Adjust
		No	Next step
2	Check air intake system and injector seat if any leakage	Yes	Check&repair air intake system
		No	Next step
3	Remove air by-pass valve, check throttle body, air by-pass valve and its pipe if any carbon deposit.	Yes	Clean it
		No	Next step
4	Disconnect connector of water temp. sensor and start engine to check if idle speed is too high.	Yes	Check&repair wiring or replace sensors
		No	Next step
5	Check ignition timing if it is under technical specifications.	Yes	Next step
		No	Check & repair ignition timing
6	Turn off ignition, switch on ignition after 3 seconds and restart engine.	Yes	
		No	Check & repair wiring

17 TROUBLESHOOTING

6	Connect PDA and switch on ignition to check ECU-J2-15 pin and J2-18 pin if it is powered normally; Check ECU-J1-9 pin and J2-2 pin if it is connected to ground normally.	Yes	Use PDA to diagnose
		No	Check & repair wiring

(11) RPM cannot go up or engine stop when acceleration

Possible causes: 1. Fuel with water; ; 2. Air intake sensor and TPS; 3. Spark plug; 4. Throttle body and its idle pipe; 5. Intake manifold; 6. Air by-pass valve; 7. Injector; 8. Ignition timing; 9. Exhaust pipe

General diagnosis procedures:

Item No.	Operation procedures	Result	Then
1	Check air filter if any blocked, and intake manifold if any leakage.	Yes	Check & repair air intake system
		No	Next step
2	Use fuel pressure meter and start engine to measure fuel pump pressure. Normal value should be around 330Kpa (3.30Bar)	Yes	Next step
		No	Check & repair fuel supply system
3	Check spark plug if it's under technical specifications.	Yes	Next step
		No	Adjust or replace
4	Remove air by-pass valve, check throttle body, air by-pass valve and its pipe if any carbon deposit.	Yes	Clean it
		No	Next step
5	Check air intake temp. sensor, TPS and its wiring if it is ok.	Yes	Next step
		No	Check & repair wiring or replace sensor
6	Remove injector and use special cleaning equipment to check if any leakage, blocked or incorrect fuel flow and so on.	Yes	Replace it
		No	Next step
7	Check fuel quality and if it's caused just after filling fuel.	Yes	Change fuel
		No	Next step
8	Check ignition order and ignition timing if it is under technical specifications.	Yes	Next step
		No	Check & repair ignition timing
9	Check exhaust pipe if any leakage or blocked.	Yes	Next step
		No	Repair & replace exhaust pipe
10	Connect PDA and switch on ignition to check ECU-J2-15 pin and J2-18 pin if it is powered normally; Check ECU-J1-9 pin and J2-2 pin if it is connected to ground normally.	Yes	Use PDA to diagnose
		No	Check & repair wiring

17 TROUBLESHOOTING

(12) Slow acceleration

Possible causes: 1. Fuel with water; 2. Air intake pressure sensor and TPS; 3. Spark plug; 4. Throttle body and its idle pipe; 5. Intake manifold; 6. Air by-pass valve; 7. Injector; 8. Ignition timing; 9. Exhaust pipe

General operation procedures:

Item No.	Operation procedures	Result	Then
1	Check air filter if any blocked, and intake manifold if any leakage.	Yes	Check&replace air intake system
		No	Next step
2	Use fuel pressure meter and start engine to measure fuel pump pressure. Normal value should be around 330Kpa (3.30Bar)	Yes	Next step
		No	Check&repair fuel supply system
3	Check spark plug if it's under technical specifications.	Yes	Next step
		No	Adjust or replace
4	Remove air by-pass valve, check throttle body, air by-pass valve and its pipe if any carbon deposit.	Yes	Clean it
		No	Next step
5	Check air intake temp. sensor, TPS and its wiring if it is ok.	Yes	Next step
		No	Check&repair wiring or replace sensor
6	Remove injector and use special cleaning equipment to check if any leakage, blocked or incorrect fuel flow and so on.	Yes	Replace it
		No	Next step
7	Check fuel quality and if it's caused just after filling fuel.	Yes	Change fuel
		No	Next step
8	Check ignition order and ignition timing if it is under technical specifications.	Yes	Next step
		No	Check&repair ignition timing
9	Check exhaust pipe if any leakage or blocked.	Yes	Next step
		No	Repair or replace exhaust pipe
10	Connect PDA and switch on ignition to check ECU-J2-15 pin and J2-18 pin if it is powered normally; Check ECU-J1-9 pin and J2-2 pin if it is connected to ground normally.	Yes	Use PDA to diagnose
		No	Check&repair wiring

(13) Power not enough when acceleration and bad performance

Possible causes: 1. Fuel with water; 2. Air intake pressure sensor and TPS; 3. Spark plug; 4. Ignition coil; 5. Throttle body and its idle pipe; 6. Intake manifold; 7. Air by-pass valve; 8. Injector; 9. Ignition timing; 10. Exhaust pipe

17 TROUBLESHOOTING

General operation procedures:

Item No.	Operation procedures	Result	Then
1	Check if any clutch slippery, or tire pressure too low, or brake too tight, or tire size incorrect and so on.	Yes	Repair
		No	Next step
2	Check air filter if any blocked, and intake manifold if any leakage.	Yes	Check&repair air intake system
		No	Next step
3	Use fuel pressure meter and start engine to measure fuel pump pressure. Normal value should be around 330Kpa (3.30Bar)	Yes	Next step
		No	Check&repair fuel supply system
4	Disconnect high-tension cable, and connect spark plug, keep it 5mm away from engine body to check if spark is ok.	Yes	Next step
		No	Check&repair ignition system
5	Check spark plug if it's under technical specifications.	Yes	Next step
		No	Adjust or replace
6	Remove air by-pass valve, check throttle body, air by-pass valve and it pipe if any carbon deposit. .	Yes	Clean it
		No	Next step
7	Check air intake temp. sensor, TPS and its wiring if it is ok.	Yes	Next step
		No	Check&repair wiring or replace sensor
8	Remove injector and use special cleaning equipment to check if any leakage, blocked or incorrect fuel flow and so on.	Yes	Replace it
		No	Next step
9	Check fuel quality and if it's caused just after filling fuel.	Yes	Change fuel
		No	Next step
10	Check ignition order and ignition timing if it is under technical specifications.	Yes	Next step
		No	Check&repair ignition timing
11	Check exhaust pipe if any leakage or blocked.	Yes	Next step
		No	Repair or replace exhaust pipe
12	Connect PDA and switch on ignition to check ECU-J2-15 pin and J2-18 pin if it is powered normally; Check ECU-J1-9 pin and J2-2 pin if it is connected to ground normally.	Yes	Use PDA to diagnose
		No	Check&repair wiring